

Service  
Service  
Service

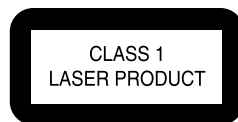

CL 26532105\_000.eps  
280802

# Service Manual



<b>Contents</b>	<b>Page</b>
1 Technical Specs and Connection Facilities	2
2 Safety Instructions, Warnings, and Notes	3
3 Directions for Use	4
4 Mechanical-, Dismantling Instructions, and Service Hints	18
5 Diagnostic Software, Trouble Shooting and Test Instructions	21
6 <i>Block-, Wiring Diagram and Testpoint Overview</i>	
Block Diagram	41
Wiring Diagram	42
Testpoint Overviews	43
7 <i>Electrical Diagrams and Print-Layouts</i>	<i>Diagram PWB</i>
Power Supply Unit	46
AV Board: SYS Clk & Control (Diagram A1)	47 53-56
AV Board: Upsampling DAC (Diagram A2)	48 53-56
AV Board: Audio DAC (Diagram A3)	49 53-56
AV Board: Curr to Volt. Converter (Diagram A4)	50 53-56
AV Board: Audio (Diagram A5)	51 53-56
AV Board: Video & SCART (Diagram A6)	52 53-56
Front Board: Display (Diagram D)	57 58-61
P-Scan Board: Line Doubler (Diagram P1)	62 65-70
P-Scan Board: Encoder (Diagram P2)	63 65-70
P-Scan Board: Video Output (Diagram P3)	64 65-70
Standby Board (Diagram S)	71 71
Double Scart Panel: Switching (Diagram S1)	72 74-76
Double Scart Panel: SCART (Diagram S2)	73 74-76

<b>Contents</b>	<b>Page</b>
8 Alignments (Not Applicable)	77
9 Circuit Descriptions	77
List of Abbreviations	86
IC Data	87
10 Spare Parts List	91

©Copyright 2002 Philips Consumer Electronics B.V. Eindhoven, The Netherlands.  
All rights reserved. No part of this publication may be reproduced, stored in a retrieval system or transmitted, in any form or by any means, electronic, mechanical, photocopying, or otherwise without the prior permission of Philips.



# 1. Technical Specifications and Connection Facilities

## Specifications

### PLAYBACK SYSTEM

DVD Video  
 SACD multi channel and SACD stereo  
 Video CD & SVCD  
 CD (CD-Recordable and CD-Rewritable)  
 MP3 CD

### TV STANDARD (PAL/50Hz) (NTSC/60Hz)

Number of lines	625	525
Playback	Multistandard	(PAL/NTSC)

### VIDEO PERFORMANCE

RGB output	0.7Vpp into 75 ohm
YUV output	Y: 1Vpp into 75 ohm Pr/Cr Pb/Cb: 0.7Vpp into 75 ohm
S-Video output	Y: 1Vpp into 75 ohm C: 0.3Vpp into 75 ohm
Video output	1 Vpp into 75 ohm
Black Level Shift	On/Off
Video Shift	Left/Right

### AUDIO FORMAT

DSD	Multichannel and Stereo
MPEG/	Compressed Digital
Dolby Digital	16, 20, 24 bits
DTS/PCM	fs, 44.1, 48, 96 kHz
MP3	96, 112, 128, 256 kbps and
(ISO 9660)	variable bit rate fs 32, 44.1, 48kHz

Full decoding of Dolby Digital and DTS multi channel sound  
 Analogue Stereo Sound  
 Dolby Surround-compatible downmix from Dolby Digital multi-channel sound  
 3D Sound for virtual 5.1 channel sound on 2 speakers

### SACD AUDIO PERFORMANCE

D/A Converter	DSD
SACD	fs 2.8224MHz DC - 100kHz
Max. output voltage (0dB)	2V rms
Channel unbalance	<0.5 dB
Cut-off frequency	50kHz (Front) 40kHz (Surround, Centre, Subwoofer)
Signal-Noise (1kHz)	-125 dB
Dynamic Range (1kHz)	-105 dB
Crosstalk (1kHz)	-120 dB
Total Harmonic Distortion (1kHz)	-100 dB

### AUDIO PERFORMANCE (Without upsampling)

DA Converter	24 bits
DVD	fs 96 kHz 4 Hz - 44 kHz
CD/Video CD	fs 44.1 kHz 4 Hz - 20 kHz
S-Video CD	fs 48 kHz 4 Hz - 22 kHz
	fs 44.1 kHz 4 Hz - 20 kHz
Signal-Noise (1kHz)	< -120 dB
Dynamic Range (1kHz)	< -95 dB
Crosstalk (1kHz)	< -110 dB
Total Harmonic Distortion (1kHz)	< -95 dB
MPEG MP3	MPEG Audio L3

### CONNECTIONS

SCART	2x Euroconnector
Y Pb/Cb Pr/Cr (480i/p)	Cinch 3x (green, blue, red)
S-Video Output	Mini DIN, 4 pins
Video Output	Cinch (yellow) 2x
Audio L+R output	Cinch (white/red)
Digital Output	1 coaxial, 1 optical IEC958 for CDDA / LPCM IEC1937 for MPEG1/2, Dolby Digital, DTS

### 6 channel analogue output

Audio Front L/R	Cinch (white/red)
Audio Surround L/R	Cinch (white/red)
Audio Centre	Cinch (blue)
Audio Subwoofer	Cinch (black)

### CABINET

Dimensions (w x h x d)	435 x 101 x 315 mm
Weight	Approximately 4.6 Kg

### POWER SUPPLY

Power inlet	110-240V, 50/60Hz
Power usage	Approx. 30W
Power usage standby	< 1W

\* typical playing time for movie with 2 spoken languages and 3 subtitle languages

**Specifications subject to change without prior notice**

CL 26532105\_050.pdf  
280802

## 2. Safety Instructions, Warnings and Notes

### 2.1 Safety Instructions

#### 2.1.1 General Safety

Safety regulations require that during a repair:

- Connect the unit to the mains via an isolation transformer.
- Replace safety components, indicated by the symbol , only by components identical to the original ones. Any other component substitution (other than original type) may increase risk of fire or electrical shock hazard.

Safety regulations require that after a repair, you must return the unit in its original condition. Pay, in particular, attention to the following points:

- Route the wires/cables correctly, and fix them with the mounted cable clamps.
- Check the insulation of the mains lead for external damage.
- Check the electrical DC resistance between the mains plug and the secondary side:
  1. Unplug the mains cord, and connect a wire between the two pins of the mains plug.
  2. Set the mains switch to the 'on' position (keep the mains cord unplugged!).
  3. Measure the resistance value between the mains plug and the front panel, controls, and chassis bottom.
  4. Repair or correct unit when the resistance measurement is less than 1 MΩ.
  5. Verify this, before you return the unit to the customer/user (ref. UL-standard no. 1492).
  6. Switch the unit 'off', and remove the wire between the two pins of the mains plug.

#### 2.1.2 Laser Safety

This unit employs a laser. Only qualified service personnel may remove the cover, or attempt to service this device (due to possible eye injury).

##### Laser Device Unit

Type	: Semiconductor laser GaAlAs
Wavelength	: 650 nm (DVD) 780 nm (VCD/CD)
Output Power	: 20 mW (DVD+RW writing) 0.8 mW (DVD reading) 0.3 mW (VCD/CD reading)
Beam divergence	: 60 degree

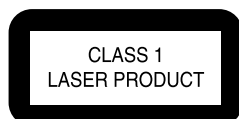



Figure 2-1 Class 1 Laser Product

**Note:** Use of controls or adjustments or performance of procedure other than those specified herein, may result in hazardous radiation exposure. Avoid direct exposure to beam.

### 2.2 Warnings

#### 2.2.1 General

- All ICs and many other semiconductors are susceptible to electrostatic discharges (ESD, symbol ). Careless handling during repair can reduce life drastically. Make sure that, during repair, you are at the same potential as the mass of the set by a wristband with resistance. Keep components and tools at this same potential. Available ESD protection equipment:
  - Complete kit ESD3 (small tablemat, wristband, connection box, extension cable and earth cable) 4822 310 10671.
  - Wristband tester 4822 344 13999.
- Be careful during measurements in the live voltage section. The primary side of the power supply (pos. 1005), including the heatsink, carries live mains voltage when you connect the player to the mains (even when the player is 'off!'). It is possible to touch copper tracks and/or components in this unshielded primary area, when you service the player. Service personnel must take precautions to prevent touching this area or components in this area. A 'lightning stroke' and a stripe-marked printing on the printed wiring board, indicate the primary side of the power supply.
- Never replace modules, or components, while the unit is 'on'.

#### 2.2.2 Laser

- The use of optical instruments with this product, will increase eye hazard.
- Only qualified service personnel may remove the cover or attempt to service this device, due to possible eye injury.
- Repair handling should take place as much as possible with a disc loaded inside the player.
- Text below is placed inside the unit, on the laser cover shield:

CAUTION VISIBLE AND INVISIBLE LASER RADIATION WHEN OPEN AVOID EXPOSURE TO BEAM  
 ADVARSEL SYNLIG OG USYNLIG LASERSTRÅLING NÅR DEKSEL ÅPNES UNNGÅ EKSPONERING FOR STRÅLING  
 ADVARSEL SYNLIG OG OSYNLIG LASERSTRÅLING NÅR DENNA DEL ÅR ÖPPNAD BETRÄKTA EJ STRÅLEN  
 VARO! AVATT AESSA OLET ALTTIINA NÄKYVÄLLE JA NÄKYMÄTT ÖMÄLLE LASER SÄTELYLLE. ÄLÄ KATSO SÄTEESEEN  
 VORSICHT SICHTBARE UND UNSICHTBARE LASERSTRAHLUNG WENN ABDECKUNG GEÖFFNET NICHT DEM STRAHL AUSSETZEN  
 DANGER VISIBLE AND INVISIBLE LASER RADIATION WHEN OPEN AVOID DIRECT EXPOSURE TO BEAM  
 ATTENTION RAYONNEMENT LASER VISIBLE ET INVISIBLE EN CAS D'OUVERTURE EXPOSITION DANGEREUSE AU FAISCEAU

Figure 2-2 Warning text

#### 2.2.3 Notes

##### Dolby

Manufactured under licence from Dolby Laboratories. "Dolby", "Pro Logic" and the double-D symbol are trademarks of Dolby Laboratories. Confidential Unpublished Works. ©1992-1997 Dolby Laboratories, Inc. All rights reserved.

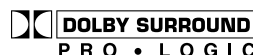

Figure 2-3

##### Trusurround

TRUSURROUND, SRS and symbol (fig 2-4) are trademarks of SRS Labs, Inc. TRUSURROUND technology is manufactured under licence from SRS labs, Inc.



Figure 2-4

## 3. Directions for Use

### Introduction

Thank you for purchasing this Philips DVD/SACD player. This Owner's Manual explains the basic operation of this DVD/SACD player.

#### Environmental Information

All unnecessary packaging has been omitted. The packaging has been made easy to separate into three materials: cardboard (box), polystyrene foam (buffer) and polyethylene (bags, protective foam sheet).

Your DVD/SACD player consists of materials which can be recycled and reused if disassembled by a specialised company. Please observe the local regulations regarding the disposal of packaging materials, exhausted batteries and old equipment.

#### Supplied accessories

- Remote control
- Batteries (two AA size) for remote control
- Audio cable
- CVBS cable
- SCART cable
- Owner's Manual
- AC Power Cord

#### Safety Information

- Before operating the DVD player, check that the operating voltage indicated on the typeplate (or the voltage indication beside the voltage selector) is identical with the voltage of your local power supply. If not, please consult your dealer.
- Place the DVD player on a flat, hard and stable surface.
- There must be sufficient room in front of the player for the disc tray to be opened.

- In cabinet, allow about 2.5cm (1 inch) of free space all around the player for adequate ventilation.

- Do not expose your player to extreme of temperatures or humidity.
- If the DVD player is brought directly from a cold to a warm location, or is placed in a very damp room, moisture may condense on the lens of the disc unit inside the DVD player. Should this occur, the DVD player would not operate normally. Leave the power on for about one hour with no disc in the DVD player until normal playback is possible.
- The mechanical parts of the set contain self-lubricating bearings, and must not be oiled or lubricated.
- **When the DVD player is switched to Standby mode, it is still consuming some power. To disconnect the system from the power supply completely, remove the AC power plug from the wall socket.**

#### Symbols Used in this Manual

The below symbols appear in some headings and notes with the following meanings:

	- Description refers to playback of DVD-video discs
	- Description refers to playback of Video CDs
	- Description refers to playback of Audio CDs
	- Description refers to playback of Super Audio CDs

#### Helpful Hints!

- **Some DVD video discs require specific functions or allow only limited functions during playback.**
- **"X" may appear on the TV screen which means that the function is not available on that specific DVD video disc.**

English

### Introduction

#### SACD: reality in sound...and vision

This SACD player will not only surprise you with its superior reproduction of almost all existing audio formats. Connected to your TV, your SACD player presents VCD and DVD-video information as perfect digital studio-quality images with truly 3-dimensional digital multi-channel audio.

#### Super Audio CD

You will recognize Super Audio CDs by the logo. There are three types of Super Audio CDs: single-layer, dual-layer and hybrid discs. Each type may contain two areas of recorded information: a High Quality Stereo area and a High Quality Multi-channel area.

- The single layer disc may contain both information areas.
- The dual layer disc may contain both information areas but a double amount of information can be stored on the disc thanks to the second layer.
- The hybrid disc may contain not only both information areas but also a second, standard CD layer, making it playable on standard CD players.

Recorded information may vary per area. This is indicated in the disc inlay. Areas can be selected separately before or during playback, while playing Super Audio CDs via the remote control or via the On-Screen Display on your TV.

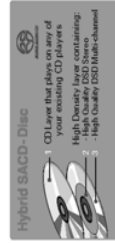

#### Reality reproduced: Super Audio CD

The future in digital sound reproduction is no longer limited to a close simulation of reality. The new audio standard IS reality! The human ear is no longer capable of distinguishing audible reality from digital reproduction. At Philips the future starts today with the Super Audio Compact Disc player. This Super Audio CD player combines superior sound quality with the possibility of playing almost all existing audio and video formats with a single player.

The Super Audio standard is based on Direct Stream Digital (DSD) technology. This new direct-stream digital format comprises a 1-bit system that has a digital sampling frequency that is 64 times higher than that of conventional audio CD. The results are spectacular: a frequency response of over 50k Hz and a 120dB dynamic range over the entire audible spectrum. Mixed with as many of the original frequencies as possible, the audio information audible for human ears sounds much more natural.

#### The next standard: hybrid disc

The Super Audio CD is the evolution of the CD that provides ultra-high-quality sound. Additional features, including multi-channel, can be offered. On the high density (HD) Super Audio CD you may have access to separate areas, containing two-channel stereo and multi-channel.

But that is not all! The hybrid version of the SACD guarantees backward compatibility with the installed base of CD and DVD players. In addition to the HD layer, the hybrid disc contains a standard density CD layer with conventional two-channel stereo CD audio information. The two layers are read from the same side of the disc. The HD layer is read by and DVD laser. The bottom reflective layer with conventional CD sound is read by the CD laser through the second, semi-transmissive HD layer.

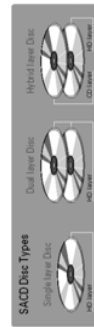

English

## Functional Overview

### Front Panel

English

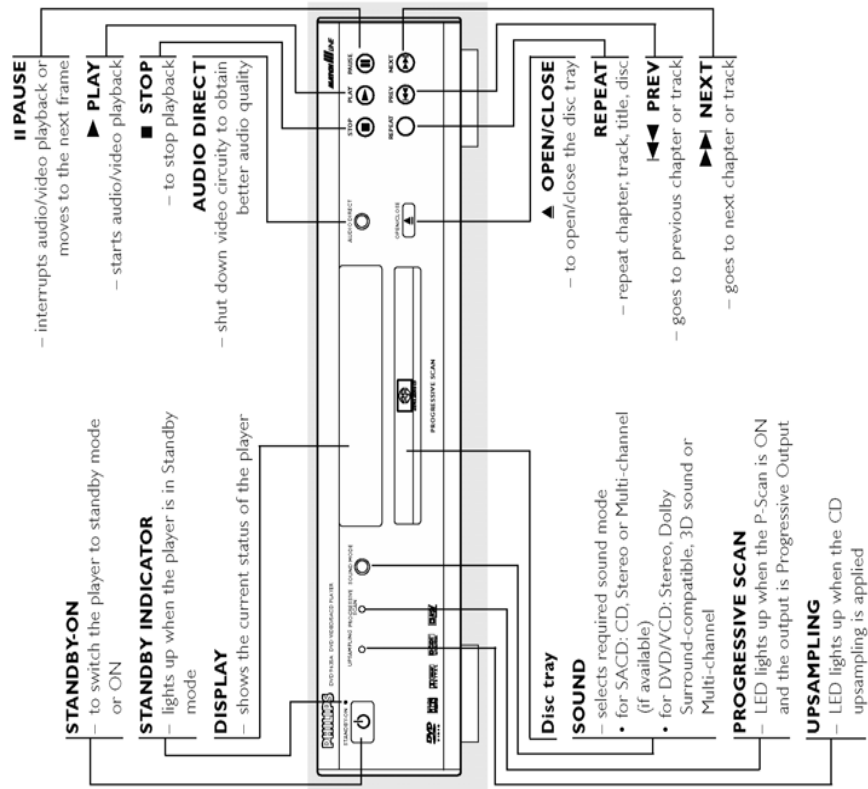

## Functional Overview

### Rear Panel

English

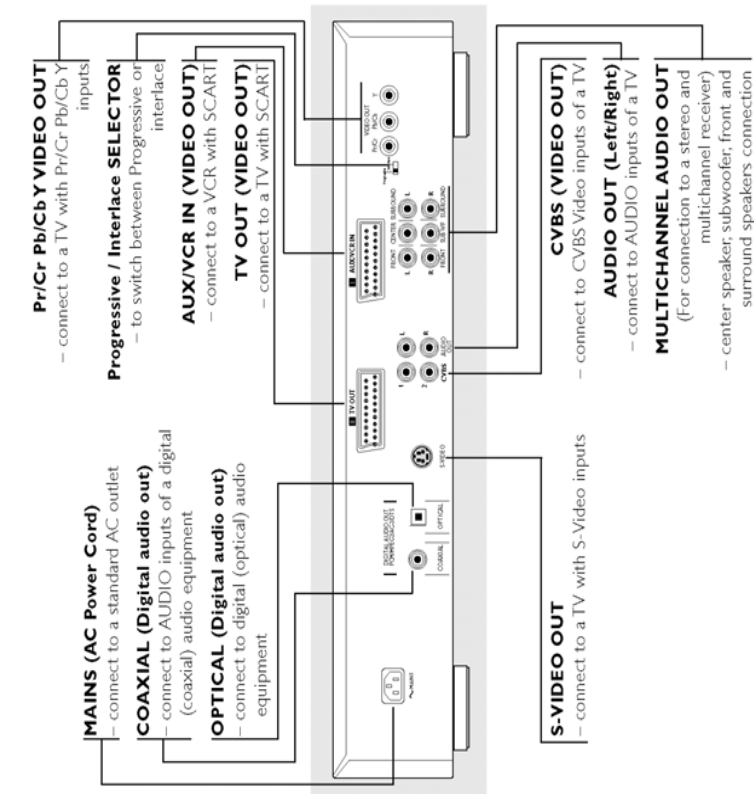

**Caution:** Do not touch the inner pins of the jacks on the rear panel. Electrostatic discharge may cause permanent damage to the unit.

## Functional Overview

### Remote Control

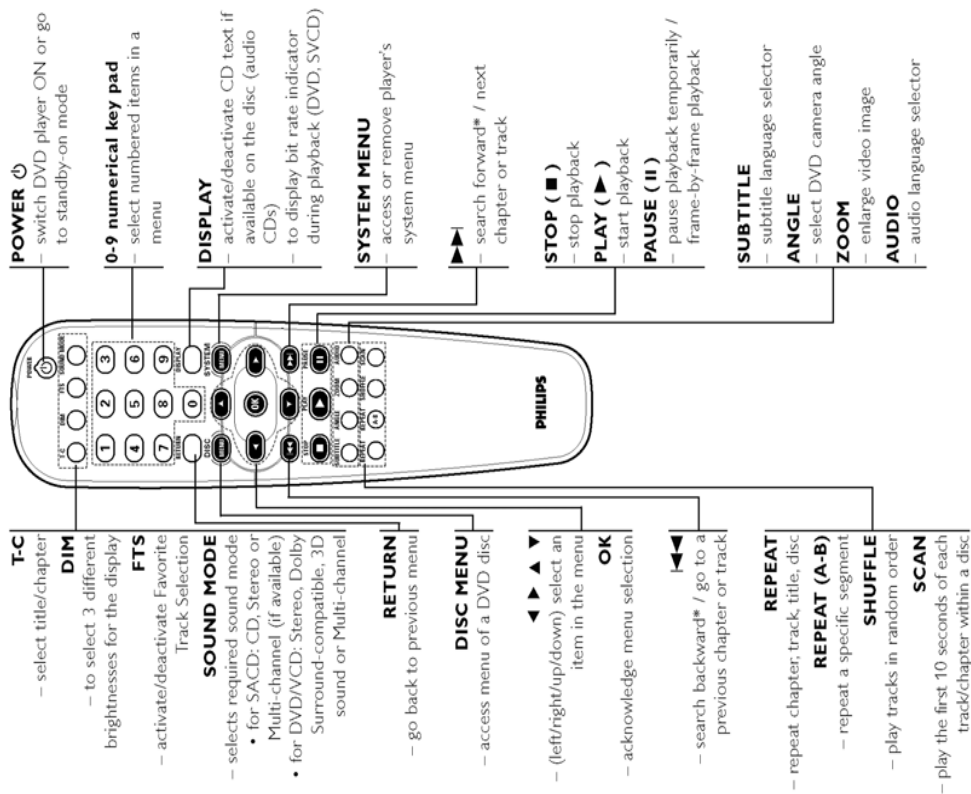

\* Press and hold key for about two seconds

## Preparation

### Basic Connections

- Please refer to the instruction books of your TV, VCR, Stereo System or other devices as necessary to make the best connections. Make one of the following connections, depending on the capabilities of your existing equipment.
- The following guidelines are options for the best picture and sound quality available on your DVD/SACD player:

### Warning!

- Never make or change connections with the power switched on.
- Connect the DVD/SACD player directly to your TV, instead of eg. a VCR, to avoid distortion because DVD video discs are copy protected.
- Do not connect the DVD/SACD player AUDIO OUT to the PHONO IN of your amplifier or receiver.

### Connecting to a TV

- 1 Connect the SCART (TV OUT) on the DVD player to the corresponding connector on the TV.

### Note:

- Ensure that the "TV" indication on SCART cable is connected to the TV set and "DVD" indication on SCART cable is connected to the DVD player.

If your TV is not equipped with SCART input, you can select the following connection:

### If your TV has a CVBS Video input connector,

- 1 Connect the CVBS VIDEO OUT on the DVD player to the CVBS VIDEO IN on the TV.
- 2 Connect the Left and Right AUDIO OUT on the DVD player to the Left and Right AUDIO IN on the TV.

### If your TV has a S-Video input connector,

- 1 Connect the S-VIDEO OUT on the DVD player to the S-VIDEO IN on the TV.
- 2 Connect the Left and Right AUDIO OUT on the DVD player to the Left and Right AUDIO IN on the TV.

### Picture

- 1 Use the CVBS Video Output for good picture quality.
- 2 Use S-Video Output for the better picture quality.
- 3 Use SCART or Pr/Cr Pb/Cb Y Output for best picture quality.

### Note:

- RGB (on SCART) and YUV (Pr/Cr Pb/Cb Y) output signals are not available at the same time.
- To choose your preferred output connection, refer section "Personal Preferences - YUV/RGB switching".

### Sound

- 1 Digital audio connections provide the clearest sound. Connect the DVD player's DIGITAL AUDIO OUT (either COAXIAL or OPTICAL) to your amplifier or receiver.

### Note:

- Digital output is not available for SACD and MP3 discs.
- 2 If digital connections are not possible, connect the DVD player's LEFT/RIGHT FRONT, CENTRE, SUBWOOFER, LEFT/RIGHT SURROUND connectors to the corresponding inputs on your multi-channel audio/video receiver.
- 3 If both the above connections are not possible, connect the DVD player's Left and Right (white and red) AUDIO OUT to your amplifier, receiver, stereo or TV.

## Preparation

### Cinemalink (on SCART)

This DVD player is equipped with cinemalink feature (from Philips) which allows a more complete control of your home audio/video (AV) equipment.

Cinemalink interconnection plug & playback will enable the AV system to recognise the users intention and automatically switch the necessary controls or input source accordingly. This will reduce the necessity of having multiple control inputs for all AV equipments (eg. TV and Amplifier).

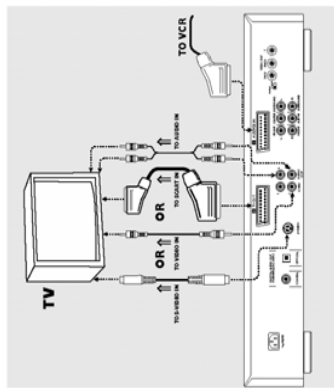

### If your TV has a component video (Pr/Cr/Pb/Cb Y) input connector,

- 1 Connect the Pr/Cr/Pb/Cb Y VIDEO OUT jacks on the DVD player to the corresponding INPUT on the TV using an optional Pr/Cr/Pb/Cb Y cable.
- 2 Connect the Left and Right AUDIO OUT jacks of the DVD player to the AUDIO Left/Right INPUT on the TV.

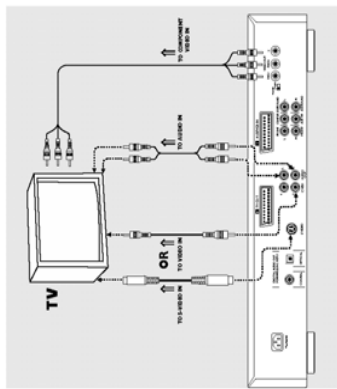

### Progressive / Interface SELECTOR

This switch will change the type of signal output from the Component Video Out on the player.

**Interface:** Select this setting when connected to a standard (interface format) TV.

**Progressive:** Select progressive when you have a TV that can accept progressive signals (480/525p) to enjoy accurate colour reproduction and high quality images.

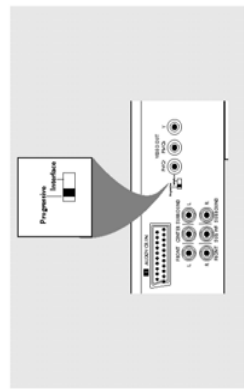

## Preparation

### Connecting to a Multi-channel Audio/(Video) receiver with 6 connectors

This DVD/SACD player contains a multi-channel decoder. This enables playback of SACDs & DVDs recorded in Multi-channel. You only need to select Multi-channel using the Sound Mode key.

- 1 Connect the audio Left and Right outputs for Front speaker connection (1) to the corresponding input sockets on your receiver using the audio cable supplied.
- 2 Connect the audio outputs for Center speaker and Subwoofer connection (2) to the corresponding inputs on your receiver using an optional audio cable.
- 3 Connect the audio Left and Right outputs for Surround speaker connection (3) to the corresponding inputs on your receiver using an optional audio cable.

#### Note:

— If the subwoofer is equipped with its own amplifier, the Subwoofer connection should be connected directly to the subwoofer.

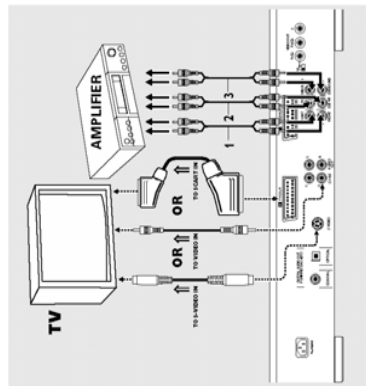

### Connecting to an Audio System

- 1 You can also listen to the sound of audio CDs, stereo SACDs, and DVD-Video discs by connecting to an optional stereo system.
- 2 Connect the FRONT LEFT/RIGHT AUDIO OUT on the DVD player multichannel audio output to the Left and Right AUDIO IN on the stereo system.

#### Important:

— For the best sound quality with playback of audio CDs and stereo SACDs, always use the left and right connectors of the high-quality stereo/Multi-channel audio output. The separate stereo output is intended only for connection to video equipment such as a TV set.

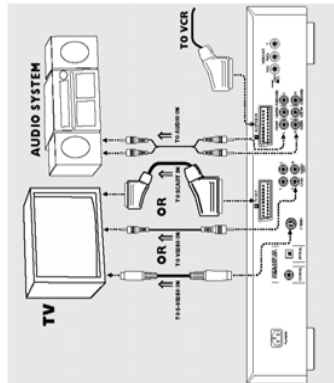

## Preparation

### Connecting to a Digital Audio Equipment

- If your receiver has an Dolby Digital, DTS or MPEG2 decoder,**
- 1 Connect the COAXIAL or OPTICAL DIGITAL AUDIO OUT of the DVD player to the COAXIAL or OPTICAL DIGITAL AUDIO IN on your receiver.
  - 2 Set the DVD player's digital output to ALL (see "Personal Preferences")

- Notes:**
- SACD audio is **NOT available on the Digital audio output (coaxial or optical) as per the SACD standard.**
  - If the audio format of the digital output does not match the capabilities of your receiver, the receiver will produce a strong, distorted sound or no sound at all.
  - MP3 Audio is not available on the Digital Output.

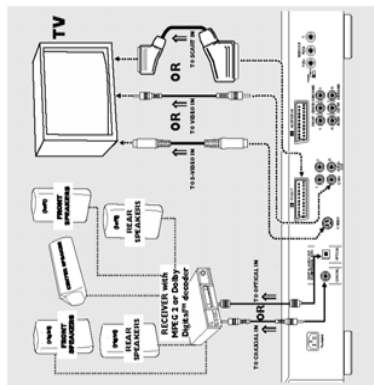

### Inserting batteries into the Remote Control

- 1 Open the battery cover.
- 2 Insert batteries (AA size) with the correct polarity as indicated by the + and - symbols inside the battery compartment.
- 3 Close the cover.

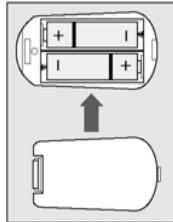

#### CAUTION!

- Remove batteries if they are exhausted or not to be used for a long time.
- Do not use old and new or different types of batteries in combination.
- Batteries contain chemical substances, so they should be disposed off properly and kept away from children.

### Using the Remote Control

- Direct the remote control at the remote sensor of the DVD/SACD player.
- Do not drop the remote control.
- Do not leave the remote control near extremely hot or humid places.
- Do not spill water or put anything wet on the remote control.

### NTSC/PAL Conversion

DVD discs are recorded according to colour system eg. NTSC and PAL. Your TV also operates according to a colour system. This DVD player is compatible with NTSC and PAL. To play on this DVD player, the colour system of the DVD disc, the TV and the DVD player should match. If all three are not the same, the DVD may play in only black and white, the picture may roll continuously or the picture may appear distorted.

To activate the conversion refer to page 17.

### Switching On

- 1 Connect the AC power cord to the power outlet.
- 2 Switch on the TV and DVD/SACD player.
- 3 Set the TV to the correct Video IN channel, (eg. EXT1, EXT2, AV1, AV2, AUDIO/MDEO, etc.) refer to your TV owner's manual for detail).
  - The player display lights up and the default screen appears on the TV.
- 4 If you are using an external equipment (eg. audio system or receiver), turn them on and select the appropriate input source that was used to connect to the DVD/SACD player output. Refer to the equipment owner's manual for detail.

#### Notes:

- If you do not have a proper picture or sound, refer to "Troubleshooting" section.

## Preparation

### Menu Bars on TV Screen

- Operations can be carried out directly via the multiple menu bars on the TV screen.
- The following functions are available via the menu bars: Pressing SYSTEM MENU keys repeatedly will toggle through menu bar 1, menu bar 2, menu bar 3 and menu bar OFF:

#### Menu bar 1



From the left,  
Personal Preferences → Subtitle Language → Audio Language → Colour → Sound

The following functions are available with activated disc, via the menu bars:

#### Menu bar 2



From the left,  
Step by step playback → Slow motion → Fast motion → Angle → Zoom

#### Menu bar 3



From the left,  
Title → Chapter → Time Search → Favourite Track Selection (FIS) → Wakeup Timer

### Temporary Feedback Field Icons

These icons will appear on the top left hand corner of your TV screen.

STOP	Scan	11	Repeat A to end
REPEAT	Repeat All	A.3	Repeat A-B
11111	Repeat Title	ANGLE	Angle
TRACK	Repeat Track	LOCKED	Child Lock On
CHAPTER	Repeat Chapter	SAFE	Child Safe
SHUFFLE	Shuffle	RESUME	Resume
SHUFFLE	Shuffle Repeat		Action Prohibited



## Preparation

### Personal Preferences

In the Personal Preferences settings menu, you can customize your player to suit your own particular requirements.

#### General operation:

- 1 Press SYSTEM MENU on the remote control.
- 2 The **TV** will be highlighted in the menu bar.
- 3 Press **V** to activate the Personal Preferences menu.
- 3 To select a preferred menu language,
  - 1 Press **V** until **TV** is highlighted.
  - 2 Press **▶** to enter the submenu and **▼** to choose Menu language.
  - 3 Use the **▲▼** to select your preferred menu language.

#### For navigation and selection in Personal preferences,

- 1 Use the **◀▶▲▼** keys to toggle through the functions and select your preferred option.
- 2 Press OK to confirm a highlighted selection. The following items are available:

### Picture

#### - TV Shape

Select the aspect ratio of the TV to be connected.

**16:9** → when you connect a wide-screen TV to the DVD/SACD player.

**4:3 LETTER BOX** → when you connect a normal TV to the DVD/SACD player. Displays a wide picture with black bands displayed on the upper and lower portions of the TV screen.

**4:3 PAN SCAN** → when you connect a normal TV to the DVD/SACD player. Displays the wide picture on the whole TV screen with a portion automatically cut off.

## Preparation

### - Smart Picture

**Colour settings** (not applicable on Component Video Output)

You can select one of five predefined sets of colour settings and one set (Personal) which you can define yourself. You can also press SMART PICTURE key (on the front panel) to access the colour settings in the menubar.



- **Digital Crystal Clear (on Pr/Cr Pb/Cb Y Progressive Scan Video Out only)**  
Digital Crystal Clear (DCC) allows you to fine-tune the following parameters on the progressive scan output.
  - **Chroma Delay** - is where the Chroma (colour) and luma (brightness) signals are not synchronised. This allows you to adjust the advance delay of the chroma signal to yield a perfectly clear picture.
  - **Gamma** - allows you to adjust the intensity of the picture non-linearly. A positive value allows you to bring out low level detail in dark scenes, while a negative value will emphasize contrast.
  - **Sharpness** - allows you to adjust sharpness of the picture.
  - **DCDi** (New Directional Correlation De-interlacing) - computes and tracks the angle of edge to fill in the missing pixel on the TV screen. Switching DCDi ON will optimise the image quality significantly, especially during the slow motion playback.
- **Aspect Ratio** - to adjust the ratio of the pictures on the TV screen.
  - NO LINEAR STRETCH: for display of 4:3 image on 16:9 TV with non-linear stretching (centre portion of screen is stretch less than the side).
  - PILLER BOX: for display of 4:3 image on 16:9 TV without stretching.
- **True Life** - produces a more dynamic picture by increasing the picture contrast and the colour intensity.

### - TV System (NTSC/PAL Conversion)

Allows you to select between PAL, NTSC and AUTO mode, depending on your TV. Player's default setting is set to AUTO. The conversions supported are as follows:

Type	Disc Format	Output format Selected mode	
		NTSC	PAL
DVD	NTSC	NTSC	AUTO
VCD	PAL	NTSC	PAL
	NTSC	NTSC	PAL

- 1 In the Personal Preferences Menu, select **TV System**.
- 2 Press **▲** or **▼** to select PAL, NTSC or AUTO.

#### Notes:

- If you have a PAL only TV, ensure that your TV System setting is PAL.
- AUTO can only be selected when using a TV that supports both the NTSC and PAL systems (multisystems).
- This setting is applicable for CVBS output on cinch and SCART only.
- Slight picture distortions may occur due to this conversion. This is normal. Thus, the AUTO format is most suitable for the best picture quality.

**Note:**  
- DCDi, Aspect Ratio and True Life adjustment are only applicable on Progressive Scan output.

## Preparation

### Sound

- **Digital output**  
Digital output selection enables you to specify the type of digital output suitable for your receiver.
- Select OFF to deactivate the DIGITAL AUDIO OUT.
- Select PCM only if your receiver is not capable of decoding multichannel audio.
- Select ALL (default setting), if you had connected your DIGITAL AUDIO OUT to a multichannel decoder receiver.

### Note:

- Digital output is not available for SACD and MP3 discs.



### – Analogue output

Select Stereo, Dolby Surround-compatible, 3D Sound or Multi-channel.  
**Multi-channel.** Select this setting when using a multi-channel audio/video receiver with six inputs. In this mode, the player will perform DTS decoding or Dolby Digital 5.1-channel decoding when applicable, and Dolby Pro Logic decoding on DVD-Video and Video-CD discs with 2-channel sound tracks. No Dolby Pro Logic decoding is done with (Super) Audio CD discs.  
**Stereo:** In this setting, the 5.1 audio channels are down-mixed to a stereo signal. Select this setting when connecting to a TV, stereo amplifier/receiver, etc.

### Notes:

- **Multi-channel output and downmixed stereo output are not available simultaneously.**
- **When multichannel is selected as analogue output, the AUDIO OUT (Left/Right) will deliver the Centre channel data and not the downmixed Left/Right.**

**Dolby Surround-compatible.** Select this setting when using an equipment with a Dolby Surround Pro Logic decoder. In this setting, the 5.1 audio channels (Dolby Digital, MPEG-2, DTS) are downmixed to a Dolby Surround-compatible 2-channel output.

**3D-Sound.** In a setup without rear speakers (analogue stereo output), 3D Sound remixes the six channels of digital surround into a two-speaker output while retaining all of the original audio information. The result is the listening sensation of being surrounded by multiple speakers.

During DVD or Video-CD playback, these values can be selected directly with the SOUND MODE key.



### – Night Mode

When set to ON, the dynamics of your sound output are optimised. High volume outputs are softened, enabling you to watch your favourite action movie without disturbing others.

### – Karaoke vocal

Put this setting to ON only when a multi-channel karaoke DVD is being played. The karaoke channels on the disc will then be mixed into a normal stereo sound.

### – SACD Bass Management Bypass

Allows you (with suitable speaker system) to bypass the bass management system for multi-channel SACD playback. This helps to preserve maximum sound quality of your SACD.

### Warning!

- **When SACD Bass Management Bypass is ON, speaker setting will not be applied during multi-channel SACD playback.**

### – PCM Output

Allows to select PCM digital output between 48kHz and 96kHz. When 48kHz has been selected, 96kHz PCM data, (if available on disc) will be converted to 48kHz.

Some 96kHz DVD are copy protected. If your PCM output selection is 96kHz, the digital output will be muted to comply with the standards. In such cases, select 48kHz to enable digital output.

### – CD Upsampling

Allows you to upsample your CD from 44.1 kHz / 16 bit to various higher sampling rates for superior CD reproductions.  
 The selections are: OFF, 96kHz/24bits, 172kHz/24bits.

The upsampling of CD can be toggle "ON/OFF" via the AUDIO key on the remote control.



## Preparation

### Speaker settings (Advance Bass Management)

Allows you to select speaker settings, volume balance and delay time, and to test the speaker settings.

Speaker settings are only active on the Multi-Channel Audio outputs for both DVD and SACD.

### Movie mode

When movie mode is set, speaker settings will not be applied during playback in the SACD Stereo mode.



### Music mode - SACD

When music mode is set, speaker settings will be applied during playback in the SACD Stereo mode only.



Additional adjustments available in SACD bass managements are:

- **Cross over frequency adjustment:** 80Hz, 100Hz and 120Hz.
- **Filter slope adjustment:** 12dB/oct, 18dB/oct and 24dB/oct.

### Note:

- **These additional adjustments are available in the subwoofer adjustments.**

## Preparation

English

### 6 Channel settings

#### Front speaker

- L (Large): When the front speakers can reproduce low frequency signals below 120Hz
- S (Small): When the front speakers cannot produce low frequency signals below 120Hz

#### Center Speaker

- L (Large): When the center speaker can reproduce low frequency signals below 120Hz
- S (Small): When the center speaker cannot produce low frequency signals below 120Hz
- Off: When the center speaker is not connected

#### Surround speakers

- L (Large): When the surround speakers can reproduce low frequency signals below 120Hz
- S (Small): When the surround speakers cannot produce low frequency signals below 120Hz
- Off: When the surround speakers are not connected

#### Subwoofer

- On: When you connect a subwoofer
- Off: When a subwoofer is not connected

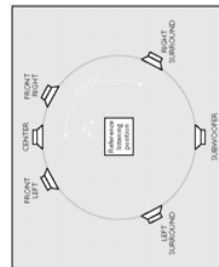

### Delay times

The DVD player is set to reproduce correctly synchronized Digital Surround Sound in a listening area where the surround speakers are about 150cm nearer to the listening position than the front speakers, and the center speaker is in line with the front speakers. To adjust for other listening area arrangements, adapt delay times according to the following:

#### Digital Surround

Measure the distances in centimeters from the front speaker plane and from the surround speaker plane to the listening positioning plane. Subtract the surround distance from the front distance and divide by 30. The result is the required Surround Channel delay time in milliseconds.

If the center speaker is on the front speaker plane, no center speaker delay is needed. If, however, it is nearer to the listening position, measure the distance in centimeters between the front and center speaker planes, and divide by 30. The result is the required Center Channel delay time in milliseconds.

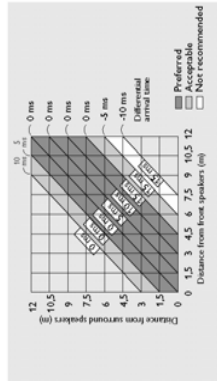

### Dolby Pro Logic

If the delay times for Surround Channel and Center Channel are set for Digital Surround mode, the delay times for Dolby Pro Logic mode will automatically be calculated and set.

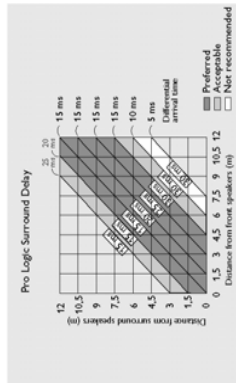

### Language

#### Selecting disc languages:

##### Menu/Audio/Subtitle language

- This is to select the audio language, subtitle language and the language used in TV screen menus or DVD menus which will always be used for every disc to be played back.
- If the language selected is not available on the disc, the default language designated by each disc will be selected.

### Features

#### - Access Control

Access Control contains the following features:  
 Child Lock - When Child Lock is set to ON, a 4-digit code needs to be entered in order to playback discs.  
 Parental control - Allows the conditional presentation of DVDs containing Parental Control information (see 'Access Control' section).

## Preparation

English

### - Status Window

Displays the current status of the player and appears with the menu bar. When disc playback is stopped, it is displayed with the 'Temporary Feedback Field' in the default screen. See 'On-Screen Display' information;  
 Factory setting is ON. Select OFF to suppress display of the Status Window.



### - Low Power Standby

If this is set to ON, the player will go in low-power standby when the standby button is pressed (front panel or remote control).

### - PBC (Playback Control - for VCD)

The Playback Control can be set to ON or OFF (see section "Special VCD & SVCD Features" for details).

### - Help text

When set to ON, help text describes the icons selected. Select OFF if you no longer require the help text.

### - Smart Power OFF

Puts the set to standby after a predefined time. This can be set to ENABLE or DISABLE.

### Other Feature

#### - Bit Rate Indicator

Press the **DISPLAY** key to activate the bit rate indicator. When activated, the bit rate for video and audio, as well as the total bit rate is displayed.

This is only applicable during playback of DVD and SVCD discs.



**Operation**

**Basic Playback**

- 1 Press **STANDBY ON** on the front panel.
- 2 Press **OPEN/CLOSE**  $\blacktriangle$  on the front panel to open disc loading tray.
- 3 Place the chosen disc in the tray with the label facing up.
- 4 Press **OPEN/CLOSE**  $\blacktriangle$  again to close the tray.  $\rightarrow$  **REPEAT** appears in the status window and on the player display, and playback starts automatically.

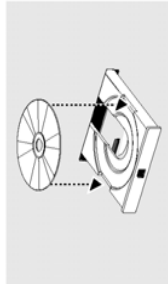

**Notes:**

- DVDs may have a region code. Your player will not play discs that have a region code different from the region code of your player.
- If "Child Lock" is set to ON and the disc inserted is not authorised, the 4-digit code must be entered and/or the disc must be authorised (see "Access Control").

**Playing a DVD-Video**

- DVD video discs may have one or more TITLES, and each TITLE may have one or more CHAPTERS.
- Playback stops at the end of each TITLE.



**Playing a title**

- 1 Insert a disc, and close the tray, playback starts automatically.
  - $\rightarrow$  The TV screen and DVD player's display show the type of disc loaded, disc's information and playing time.
- 2 When the Disc Menu appears on the TV screen, use  $\blacktriangle$ ,  $\blacktriangleright$ ,  $\blacktriangleleft$ ,  $\blacktriangledown$  keys or numerical keys on the remote control to select an option and continue playback.
- 3 If the titles are numbered, press the numerical keys or use the  $\blacktriangle$  keys to select desired title in the menu bar.
- 4 To stop playback, press **STOP**.

**Smart Resume**

The playback of a disc can be interrupted at any point and then resumed from the point where the playback was last stopped. The **RESUME** feature applies not only to the disc in the player, but also the last 20 discs you have played.

**To interrupt playback,**

- Press **STOP** to interrupt playback.
- $\rightarrow$  The help line text appears "Press Stop again to start from beginning" for 5 seconds.

**Playback when a disc has not been ejected,**

- Pressing **PLAY** will automatically resume playback from the point where playback was interrupted.

**OR**

- Press **STOP** again and then press **PLAY**.
- $\rightarrow$  Playback will start from the beginning of the discs.
- If you press **PLAY** when resume icon appears on the screen, resume playback starts from the point where playback was interrupted.

**Playback when a disc has been ejected,**

- Reload the disc.
- $\rightarrow$  Playback starts from the beginning of the disc.
- If you press **PLAY** when resume icon appears on the screen, resume playback starts from the point where playback was interrupted.

**Note:**

- Resume feature is also applicable to VCDs and SVCDs.

**Video CD and Super Video CD**

The current VCD 2.0 and Super-Video CD 1.0 standard features are:

**Support following VCD and SVCD formats:**

Features	Video CDs 2.0	Super-Video CDs 1.0
Video	H.261, H.262	H.261, H.262
Bit rate	constant 1,150Kbps	variable up to 2.4 Mbps
Resolution	NTSC 352x288, 288x224	NTSC 480x320, PAL 576x480
Sampling frequency	44.1KHz	48KHz
Sampling resolution	16-bit	16-bit
Sampling rate	44.1KHz	48KHz
Audio	H.261 Layer B	H.261 Layer B
Audio channels	2 channels	2 channels
Audio bit rate	1 stereo / 2 mono	1 stereo / 4 mono
Intermodulation	Stereo with Dolby Pro-Logic	H.261 (5+1) continuous
Sub-coding	4 colour CLUT	4 colour CLUT

**Following formats can't be supported in VCD:**

- HQ-VCD is encoded at 2.4Mbps or 2.6Mbps
- XVCD (eXtended VCD) with higher resolution and data rate.
- The file ending with "DIVX" format.

- Video CDs may have one or more TRACKS, and TRACKS may have one or more INDEXES.
- To make easy and convenient access, you can move between TRACKS and INDEXES.
- Some Video CDs have Play Back Control (PBC), which is a predefined playback sequence stored on the disc (see Playback Control section).

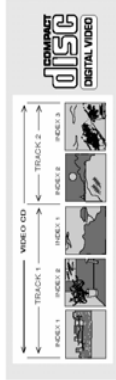

**Playing a disc**

- 1 Insert the disc, and close the tray, playback starts automatically.
  - $\rightarrow$  The number of tracks and the total playing time of the disc will appear on the TV screen and DVD player's display.
- 2 Press **PLAY**.
  - $\rightarrow$  The current track number and its elapsed playing time will be displayed.
- 3 Playback will stop at the end of the disc.
- 4 To stop playback, press **STOP**.
- 5 Disc Resume feature is also applicable for VCDs and SVCDs (see "Smart Resume" section).

**Operation**

**Playing a Super Audio CD**

- Super-Audio CDs contain only TRACKS
- Select tracks using the menu bar on the TV screen or by pressing the numerical keys directly.
- If SACD-text or CD-text is available on the disc, it will be displayed on both the TV screen and player's front panel.
- Favourite Track Selection (FTS) programming is NOT possible on SACD discs.



**Playing a disc**

- 1 Insert a disc and close the tray, playback starts automatically.
  - $\rightarrow$  The TV screen will display the number of tracks for selection, current playing status and current playing layer.
- 2 Playback will stop at the end of the disc.
- 3 To stop playback, press **STOP**.

**Sound Mode - SACD playback**

- If the default Sound mode is set to multi channel and the inserted disc does not contain this mode, the player will automatically select the stereo mode.
- On hybrid discs (with SACD and CD layers), the player will always start playing the SACD layer.
- While the SACD disc is being played, the currently played layer is shown on the player front display as follows:
  - SA 6 (for SACD Multi channel)
  - SA 2 (for SACD stereo)
  - CD (for CD layer of SACD)
- You can switch between SACD multi channel and SACD stereo layers (depending on availability of the mode on the disc) while the disc is playing by pressing the Sound Mode button on the remote control or the player front. The mode change will be indicated on the player front display.
- Switching between the SACD and CD layer is not possible during playback.

## Operation

- 1 Press **STOP** to stop the playback.
- 2 Press Sound Mode button on the remote control or the player front to toggle between SACD multi channel, SACD stereo and CD layers (depending on availability of the mode on the disc).  
→ The mode change will be indicated on the player front display.

### Playing an Audio CD

- Audio CDs contain only TRACKS.
- They can be played on your DVD player with the audio output connected to a stereo system or to your TV.
- If CD-text is available on the disc, it will be displayed on both the TV screen and player's front display.
- Select tracks using the menubar on the TV screen or by pressing the numerical keys directly.
- Your DVD player also allows you to compile Favourite Track Selection (FIS) programmes for your discs by selecting or excluding tracks of your choice (see FIS Programme - Audio CDs).

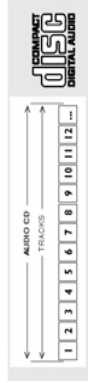

### Playing a disc

- 1 Insert a disc and close the tray, playback starts automatically.  
→ The TV screen will display the number of tracks for selection and current playing status. Playback will stop at the end of the disc.
- 2 To stop playback, press **STOP**.

### Special DVD Features

DVDs may contain menus to navigate the disc and access special features. Press the appropriate numerical key or use the **▶▶▶▶▶** keys to highlight your selection in the DVD menu and press **OK** to confirm.

### Title/Disc menu

- 1 Press **DISC MENU**.  
→ If the current title has a menu, the menu will appear on the screen. Otherwise, the disc menu will be displayed.  
If disc menu is available on the disc, audio language, subtitle options, chapters for the title and other options will appear for selection.
- 2 To remove the title/disc menu, press **DISC MENU** again.

### Camera Angle

Some discs contain scenes which have been shot simultaneously from various angles. This DVD player allows you to select the desired camera angle.

- When the DVD player encounters a scene shot in multiple angles, it will give an indication on the "Temporary Feedback Field".  
→ The angle icon remains displayed until multiple angles are no longer available.
- Use the **▲▼** to select the required angle.
- → Playback changes to the selected angle.
- You can also select **↵ (ANGLE)** in the menu bar or press the **ANGLE** button on the remote control directly.

### Changing the audio language

- 1 Select **↵ (AUDIO)** in the menu bar or press the **AUDIO** button on the remote control directly.
- 2 Press **AUDIO** or **▲▼** repeatedly to select the different languages.

### Subtitle Language

- 1 Select **↵ (SUBTITLE)** in the menu bar or press the **SUBTITLE** button on the remote control directly.
- 2 Press **SUBTITLE** or **▲▼** repeatedly to select the different subtitles.

## Special VCD & SVCD Features

### Playback Control (PBC)

Playback control is a feature on some Video CDs / Super-Video CDs that enables interactive use.

Video CD discs with Playback Control features enables user to access a selected track directly from the disc menu.

- 1 Load a Video CD with PBC and press **PLAY**.
- 2 Go through the menu with the keys indicated on the TV screen until your chosen passage starts to playback. If a **PBC** menu consists of a list of tracks, you can select a track directly.
- 3 Enter your choice with the numerical keys (0-9).
- 4 Press **RETURN** to go back to the previous menu, if applicable on the menu.
- 5 You may also select **PBC OFF** under Personal Preferences.  
→ When set to OFF, PBC menus are not activated for further playback.

### Special CD, SACD & MP3 Features

#### CD text, SACD text and MP3 text

- 1 Some CD, SACD or MP3-CD discs may contain text information (eg track names, album name, artist name etc.) which will appear on the DVD/SACD player and TV screen during playback.  
By default, CD text display is set to ON.  
To switch off the CD text display, press **DISPLAY** on the remote control during playback.
- 2 Press **DISPLAY** on the remote control again to switch on the text display mode.



## General Features

### Note:

- Unless stated, all operations described are based on remote control use. Some operations can be carried out using the menu bar on the TV screen.

### Moving to another title/chapter

#### DVD VCD

When a disc has more than one title/track or chapter, you can move to another title/chapter as follows:

- 1 Press **SYSTEM MENU**, then select **T** or **C** in the menu bar.
- 2 Press **▲▼** or numerical keys to select a title/chapter.

#### CD SACD

- 1 Press **▶▶▶▶▶** or **◀◀◀◀◀** briefly during playback to go to the next track or to return to the beginning of the current track respectively.
- 2 Press **◀◀◀** twice briefly to step back to the previous track.
- 3 To go directly to any track enter the track number using the numerical keys (0-9).

### Search

#### DVD VCD SACD

- 1 Select **↵ (FAST MOTION)** in the menu bar and press **▶**.
- 2 Use the **◀▶** keys to select the required speed: 32, -8 or -4 (backward), or +4, +8, +32 (forward).
- 3 Select 1 to play the disc at normal speed again.
- 4 To exit **FAST MOTION** mode, press **PLAY** or **▶**.

#### CD

- To search forward or backward through different speeds, you can also hold down **▶▶▶▶▶** or **◀◀◀◀◀** for more than two seconds.

## Operation

English

- 1 Select **SLOW MOTION** in the menu bar and press **V**.  
→ Playback will pause.
- 2 Use the cursor keys **←** and **→** to select the required speed: -1, -1/2, -1/4 or -1/8 (backward), or +1/8, +1/4, +1/2 or +1 (forward).
- 3 Select 1 to play the disc at normal speed again.
- 4 If **II** is pressed, the speed will be set to zero (PAUSE).
- 5 To exit slow motion mode, press **PLAY**.

### Still Picture and Frame-by-frame playback **DVD** **YCD** **SACD**

- 1 Select **STEP** in the menu bar and press **V**.  
→ Playback will pause.
- 2 Use the cursor keys **←** and **→** to select the previous or next picture frame.
- 3 To exit step by step playback, press **PLAY** or **▲**.

#### Note:

- You can also activate **frame-by-frame** playback by pressing the **PAUSE** key repeatedly on the remote control.

### Scan **DVD** **YCD** **CD** **SACD**

Scanning plays the first 10 seconds of each chapter/track on the disc.

- 1 Press **SCAN**.
- 2 To continue playback at your chosen chapter/track, press **SCAN** again or press **PLAY**.

### Repeat

#### **DVD**

- To repeat the current chapter, press **REPEAT**.
- → **REPEAT CHP** appears on the front display.
- To repeat the current title, press **REPEAT** a second time.
- → **REPEAT TTL** appears on the front display.
- To repeat the entire disc, press **REPEAT** a third time.
- → **REPEAT DISC** appears on the front display.
- To exit Repeat mode, press **REPEAT** a fourth time.

### **YCD** **CD** **SACD** Repeat track/disc

- To repeat the current track, press **REPEAT**.
- → **REPEAT TRK** appears on the front display.
- To repeat the entire disc, press **REPEAT** a second time.
- → **REPEAT DISC** appears on the front display.
- To exit Repeat mode, press **REPEAT** a third time.

### Repeat A-B **DVD** **YCD** **CD** **SACD**

— **DVD-Video Discs: repeat a sequence in a title**

— **Video and Audio CDs: repeat a sequence in a track**

- 1 Press **REPEAT** A-B at your chosen starting point.
  - 2 Press **REPEAT** A-B again at your chosen end point.
  - 3 → **REPEAT A-B** appears briefly on the front display, and the repeat sequence begins.
- To exit the sequence, press **REPEAT** A-B.

### Shuffle

#### **DVD**

This shuffles the playing order of chapters within a title, if the title has more than one chapter. Press **SHUFFLE** during playback.

- 1 → **SHUFFLE** appears on the screen for about two seconds.
- 2 To return to normal playback, press **SHUFFLE** again.

### **YCD** **CD** **SACD**

This shuffles the playing order of tracks within a disc, if the disc has more than one track.

- 1 Press **SHUFFLE** during playback.
- 2 → **SHUFFLE** appears on the screen for about two seconds.
- 2 To return to normal playback, press **SHUFFLE** again.

## Operation

English

- 6 To exit **ZOOM** mode, select zoom factor to "Off" (zoom factor 1) in the menu bar.



- **Time search **DVD** **YCD****  
The Time Search function allows you to start playing at any chosen time on the disc.  
Select **TIME-SEARCH** in the menu bar and press **V**.  
→ Playback will pause.
- → The elapsed playing time is displayed in a time edit box.

- 2 Enter hours, minutes and seconds from left to right in the time edit box using remote control numerical key pad.  
→ Each time an item has been entered, the next item will be highlighted.
- 3 Press **OK** to confirm the selected time.  
→ The time edit box will disappear and playback starts from the selected time position on the disc.



- 4 Press **SYSTEM MENU** to remove the menu bar.

### **FTS** Video/Audio Programme

- The **FTS**-Video function allows you to store your favourite titles and chapters (**DVD**) and favourite tracks and indexes (**VCD**, **CD**) for a particular disc in the player memory.
- Favourite Track Selection (**FTS**) list contains up to 20 items (titles, chapters).
- The most recent programme list will be placed on top of the existing list.

### **DVD** **YCD**

#### Storing a Programme

- 1 Load a disc and stop playback.
- 2 Select **VIDEO FTS** in the menu bar.
- 3 Press **V** to open the menu bar.  
→ The **VIDEO FTS** menu appears.

#### Storing titles/tracks

- 1 Press **V** to select **TITLES/TRACKS**.
- 2 Use **▶** and **◀** to select the require title/tracks.
- 3 Press **OK** to store the entire selected title/tracks.  
→ The title number will be added to the list of selections.

### **DVD** **YCD**

#### Zoom **DVD** **YCD**

The Zoom function allows you to enlarge the video image and to pan through the enlarged image.

- 1 Select **ZOOM**.
- 2 Press **▲** and **▼** to activate the **ZOOM** function and select the required zoom factor: 1.33 or 2 or 4.  
→ Playback will continue.
- → The selected zoom factor and 'Press **OK** to pan' appears below the menu bar.
- → The zoomed picture will appear on the TV screen.
- 3 Press **OK** to confirm the selection.
- 4 → The panning icon appears on the screen.
- 5 Use the **◀** and **▶** keys to pan across the screen. When **OK** is pressed only the panned picture will be shown on the screen.

## Operation

English

- Press **▼** on the selected chapter/indexes number:  
→ The chapter/indexes number will be highlighted.
- Use **▶** and **◀** to select the required chapter number.
- Press **OK** to confirm the selection.  
→ The selected chapter/indexes confirmation will be added to the list of selections.
- Press **SYSTEM MENU** to exit the **VIDEO FTS** menu.

### Switching a Programme ON/OFF

- Use **▶▼** to move and select desired tracks.
- Press **▶** or **◀** to select either **ON** or **OFF**.

### Erasing a selection in a Programme

- While playback is stopped, select **VIDEO FTS** in the menu bar.
- Use **▶** to select **PROGRAM**.
- Use **▶** and **◀** to select the required number.
- Press **OK** to erase the selection.
- Press **SYSTEM MENU** to exit.

### Erasing all selections

- While playback is stopped, select **VIDEO FTS** in the menu bar.
- Use **▶** to select **CLEAR ALL** and press **OK**.  
→ All selections will be erased.
- Press **SYSTEM MENU** to exit.



## CD

### Storing a Programme

- Load a disc and stop playback.
- Press **▶** to go to the list of available tracks.
- Use **▶** and **◀** to select the required tracks or directly using remote control numeric key.
- Press **OK** to store the selected tracks.  
→ The track number will be added to the list of selections.

### Switching a Programme ON/OFF

- Use **▶▼** to move and select desired tracks.
- Press **▶** or **◀** to select either **ON** or **OFF**.

### Erasing a track in a Programme

- Use **▶** to go to the programmed tracks.
- Use **▶** and **◀** to select the required number.
- Press **OK** to erase the selection.
- Press **SYSTEM MENU** to exit.

### Erasing all selections

- Use **▶** to select **CLEAR ALL** and press **OK**.  
→ All selections will be erased.



### Note:

- Audio track programming function is not available for **MP3-CD** and **SACD** discs.

### Auto Wake-up Timer

The wake-up timer allows your player to turn on after a preset time.

- Select **⏰** in the menu bar.
- Press **▶**.
- Time edit box will appear.  
Use the **▲** or **▼** to select the sleep time. The maximum time you can select is 600 minutes. Selection is made by 30 minutes steps each time.
- Press **OK** to confirm the selection.
- The Wake-up Timer will activate when the set is switched to standby-mode.

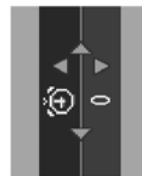

## Operation

English

### Album/Title

This feature allows you to view and select the next or previous MP3 disc, Album/Title.

- Press **▶▼** to scroll through the previous or next Album.
- Press **◀▶** to scroll through the previous or next Track.
- You can also select the desired album/track number directly using the numeric keys on the remote control.

### Note:

- In **STOP mode**: numbers are used for **ALBUM** selection.
- In **PLAY mode**: numbers are used for **TRACK** selection.



- Only the following functions are possible for MP3 discs:

- STOP / PLAY / PAUSE
- SKIP NEXT / PREVIOUS
- REPEAT (TRACK / ALBUM / DISC)

### MP3 Discs - Album/Track/Disc

- To repeat a track, press **REPEAT**.
- **REPEAT TRK** appears on the player display.
- To repeat an album, press **REPEAT** a second time.
- **REPEAT ALBM** appears on the player display.
- To repeat the entire disc, press **REPEAT** a third time.
- **REPEAT DISC** appears on the player display.
- To exit **REPEAT** mode, press **REPEAT** a fourth time.
- **REPEAT OFF** appears on the player display.

### MP3 Disc Features

Support following **MP3-CD** formats (ISO9660 format):

- Max: 30 characters
- Max: nested directory is 8 levels
- The max:ALB number is 32
- Supported VBR bit-rate
- Supported sampling frequencies for MP3 disc are: 32 kHz, 44.1 kHz, 48 kHz
- Supported Bit-rates of MP3 disc are: 32, 64, 96, 128, 192, 256 (kbps)

### Following formats can't be supported

- The files like \*.VMA, \*.AAC, \*.DLF, \*.M3U, \*.PLS Chinese filenames
- The non-session closed discs
- The discs recorded under UDF format

Downloading MP3 files from the Internet or copying songs from your own legal discs is a delicate process.

Sound Quality	Bit Rate	Approximate Audio Ratio	Approximate total MP3-CD time	Comment
16 bits	32 kbps	20:1	30 hrs	Low quality (not recommended)
16 bits	44 kbps	25:1	22 hrs	
16 bits	48 kbps	33:1	16 hrs	Reduced sound quality
16 bits	64 kbps	40:1	12 hrs	Compression rate
16 bits	96 kbps	50:1	8 hrs	
16 bits	128 kbps	64:1	6 hrs	Compression rate
16 bits	160 kbps	80:1	4 hrs	Compression rate
16 bits	192 kbps	100:1	3 hrs	Compression rate

You may experience an occasional "skip" while listening to your MP3 files. This is normal.

### Additional note for MP3 disc Playback:

- In compliance with the SDML digital-out is muted while playing MP3 discs.
- Due to the recording nature of Digital Audio MP3 (DAM), only Digital Audio music will play.
- The disc reading time may exceed 10 seconds due to the large number of songs compiled onto one disc.
- For multi-session discs, only the first session will be available.

## Access Control

English

### Child Lock DVD XCD

#### Activating/deactivating the Child Lock

- When disc playback is stopped, select **ACCESS CONTROL** in the Personal Preferences menu using the **▲▼** keys.
- Enter a 4-digit code of your own choice twice.
- Move to: "**CHILD LOCK**", using the **▲▼** keys.
- Move to **ON** / **OFF** using the **▶** key.
- Select **ON** using the **▲▼** keys.
- Press **OK** or **◀** to confirm, then press **◀** again to exit the Personal Preferences menu.
- Now unauthorised discs will not be played unless the 4-digit code is entered.
- Select **OFF** to deactivate the **CHILD LOCK**.

#### Notes:

- Confirmation of the 4-digit code is necessary when:
- The code is entered for the very first time (see above).
- The code is changed or cancelled (see 'Changing the 4-digit code').



#### Authorising discs

- Insert the disc.
- You will be asked to enter your secret code for 'Play Once' or 'Play Always'.
- If 'Play Once', disc can be played when in the player and the player is ON.
- If 'Play Always', disc will become authorised and can always be played, even if the Child Lock is set to ON.

#### Notes:

- The player memory can maintain 120 authorised ('Child safe') disc titles. A disc will be placed in the list when 'Play Always' is selected.

- Each time a 'child safe' disc is played, it will be placed on top of the list. When the list is full, the last disc in the list will be replaced when a new disc is added.
- Double-sided DVDs and multi-volume VCDs may have a different ID for each side. In order to make the disc child safe, each side has to be authorised.



#### Deauthorising discs

- Insert the disc.
- Playback starts automatically.
- Press **■** while **⊙** is visible.
- The **⊙** will appear and the disc is now deauthorised.

#### Parental Control DVD

Movies on DVDs may contain scenes not suitable for children. Therefore, discs may contain 'Parental Control' information which applies to the complete disc or to certain scenes on the disc. These scenes are rated from 1 to 8, and alternative, more suitable scenes are available on the disc. Ratings are country dependent. The 'Parental Control' feature allows you to prevent discs from being played by your children or to have certain discs played with alternative scenes.



## Access Control

English

### Changing the 4-digit code

- When disc playback is stopped, select **ACCESS CONTROL** in the Personal Preferences menu using the **▲▼** keys.
- Enter the current 4 digit code.
- Move to **CHANGE CODE** using the **▶** and press the **▶** key.
- Enter the new 4-digit code.
- Press **OK**.
- Press **◀** to exit the menu.
- The new 4 digit code will be take effect.

### If you forget your 4 digit code

- Press **■** to exit the 'Child Safe' screen.
- Select **ACCESS CONTROL** in the Personal Preferences menu using the **▲▼** keys.
- The 4-digit code can be cancelled by pressing **■** four times in the 'Access Control' dialog.
- You can then enter a new code (twice) as described above in 'Changing the 4 digit code'.

### Parental Control Disclaimer

This DVD/SACD player features the **PARENTAL CONTROL** system which is to activate when playing DVD discs furnished with certain software coding only. Also note that at the time of release of this DVD/SACD player, certain aspects of the technical standards had not been settled between set makers and the disc industries. On this basis, Philips cannot guarantee the functioning of the **PARENTAL CONTROL** system and denies any liability associated with unintended watching of disc content.

If in doubt, please make sure the disc plays according to your **PARENTAL CONTROL** settings before you allow children access to the player.

### Activating/Deactivating Parental Control

- When disc playback is stopped, select **ACCESS CONTROL** in the Personal Preferences menu using the **▲▼** keys.
- Enter your 4-digit code. If necessary, enter the code a second time.
- Move to **Parental Control** using the **▲▼** keys.
- Move to value adjustment (1-8) using the **▶** key. Then use the **▲▼** keys or the numerical keys on the remote control to select a rating from 1 to 8 for the disc inserted.

#### Rating 0 (displayed as '- -'):

Parental Control is not activated. The Disc will be played in full.

#### Ratings 1 to 8:

The disc contains scenes not suitable for children. If you set a rating for the player, all scenes with the same rating or lower will be played. Higher rated scenes will not be played unless an alternative which has the same rating or lower is available on the disc. If no suitable alternative is found, playback will stop and the 4-digit code has to be entered.

- Press **OK** or **◀** to confirm, then press **◀** again to exit the Personal Preferences menu.



### Country

- When disc playback is stopped, select **ACCESS CONTROL** in the Personal Preferences menu using the **▲▼** keys.
- Enter the 4-digit code.
- Move to **CHANGE COUNTRY** using the **▶** key.
- Press the **▶** key.
- Select a country using **▲▼**.
- Press **OK** or **◀** to confirm, then press **◀** again to exit the menu.



## Troubleshooting

Problem	Solution
<b>No audio at digital output</b>	<ul style="list-style-type: none"> <li>Check the digital connections.</li> <li>Check the settings menu to make sure the digital output is set to ALL or PCM.</li> <li>Check if the audio format of the selected audio language matches your receiver capabilities.</li> </ul>
<b>No sound and picture</b>	<ul style="list-style-type: none"> <li>Check that the SCART cable is connected to the correct device (See Connecting to a TV)</li> </ul>
<b>Disc can't be played</b>	<ul style="list-style-type: none"> <li>Ensure the disc label is facing up.</li> <li>Check if the disc is defective by trying another disc.</li> </ul>
<b>Picture freezes momentarily during playback</b>	<ul style="list-style-type: none"> <li>Check the disc for fingerprints/scratches and clean with a soft cloth wiping from centre to edge.</li> </ul>
<b>No return to start-up screen when disc is removed</b>	<ul style="list-style-type: none"> <li>Reset the unit by switching the player off, then on again.</li> </ul>
<b>The player does not respond to the remote control</b>	<ul style="list-style-type: none"> <li>Aim the remote control directly at the sensor on the front of the player.</li> <li>Reduce the distance to the player.</li> <li>Replace the batteries in the remote control.</li> <li>Re-insert the batteries with their polarities (+/- signs) as indicated.</li> </ul>
<b>Buttons do not work or player stops responding</b>	<ul style="list-style-type: none"> <li>To completely reset the player, unplug the AC cord from the AC outlet for 5-10 seconds.</li> </ul>
<b>Player does not respond to some operating commands during playback.</b>	<ul style="list-style-type: none"> <li>Operations may not be permitted by the disc. Refer to the instructions of the disc.</li> </ul>
<b>DVD/SACD Video player cannot read CDs/IDVDs</b>	<ul style="list-style-type: none"> <li>Use a commonly available cleaning CD/DVD to clean the lens before sending the DVD/SACD player for repair.</li> </ul>

*If you are unable to remedy a problem by following these hints, consult your dealer or service centre (HOTLINE).*

## Maintenance

- Cleaning the Cabinet**
  - Use a soft cloth slightly moistened with a mild detergent solution. Do not use a solution containing alcohol, spirits, ammonia or abrasives.
- Cleaning Discs**
  - When a disc becomes dirty, clean it with a cleaning cloth. Wipe the disc from the centre out. Do not wipe in a circular motion.
  - Do not use solvents such as benzine, thinner, commercially available cleaners, or antistatic spray intended for analogue records.
- Cleaning the disc lens**
  - After prolonged use, dirt or dust may accumulate at the disc lens. To ensure good playback quality, clean the disc lens with Philips CD Lens Cleaner or any commercially available cleaner. Follow the instructions supplied with the cleaner.

## Troubleshooting

**WARNING**  
*Under no circumstances should you try to repair the system yourself, as this will invalidate the warranty. Do not open the system as there is a risk of electric shock.*  
*If a fault occurs, first check the points listed below before taking the system for repair.*

Problem	Solution
<b>No power</b>	<ul style="list-style-type: none"> <li>Check if the AC power cord is properly connected.</li> </ul>
<b>No picture</b>	<ul style="list-style-type: none"> <li>Check if the TV is switched on.</li> <li>Check the video connection.</li> </ul>
<b>Distorted picture</b>	<ul style="list-style-type: none"> <li>Sometimes a small amount of picture distortion may appear. This is not a malfunction.</li> </ul>
<b>Completely distorted picture or black/white picture with DVD/SACD or Video CD</b>	<ul style="list-style-type: none"> <li>Make sure the NTSC/PAL setting at the DVD player matches the video signal of your television. (See NTSC/PAL Conversion/Settings)</li> </ul>
<b>No sound or distorted sound</b>	<ul style="list-style-type: none"> <li>Adjust the volume.</li> <li>Check that the speakers are connected correctly.</li> </ul>

English

English

# 4. Mechanical-, Dismantling Instructions, and Service Hints

## 4.1 Dismantling Instructions

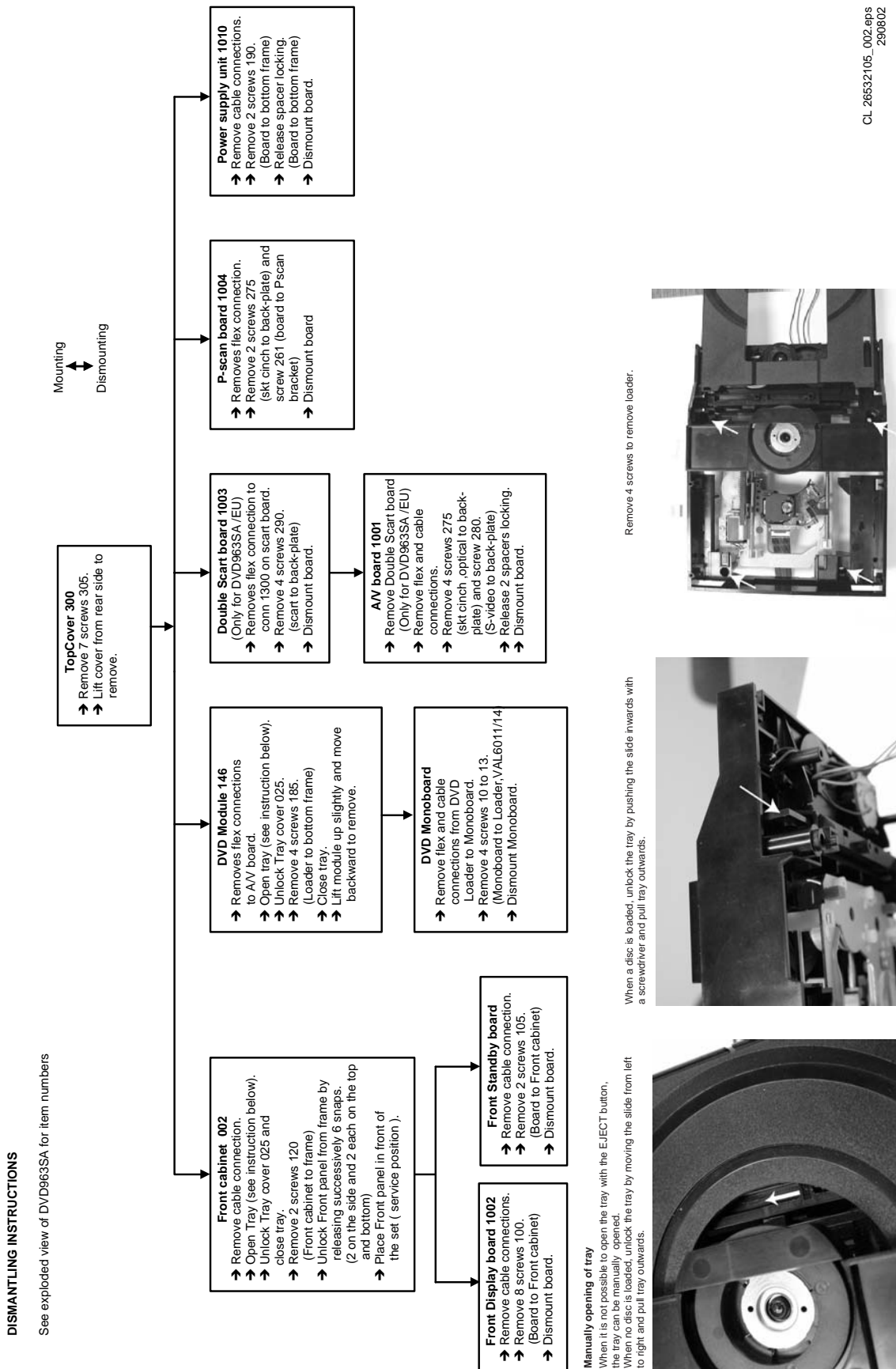

CL 26532105\_002.eps  
290802

Figure 4-1 Dismantling Instructions

4.2 Exploded View

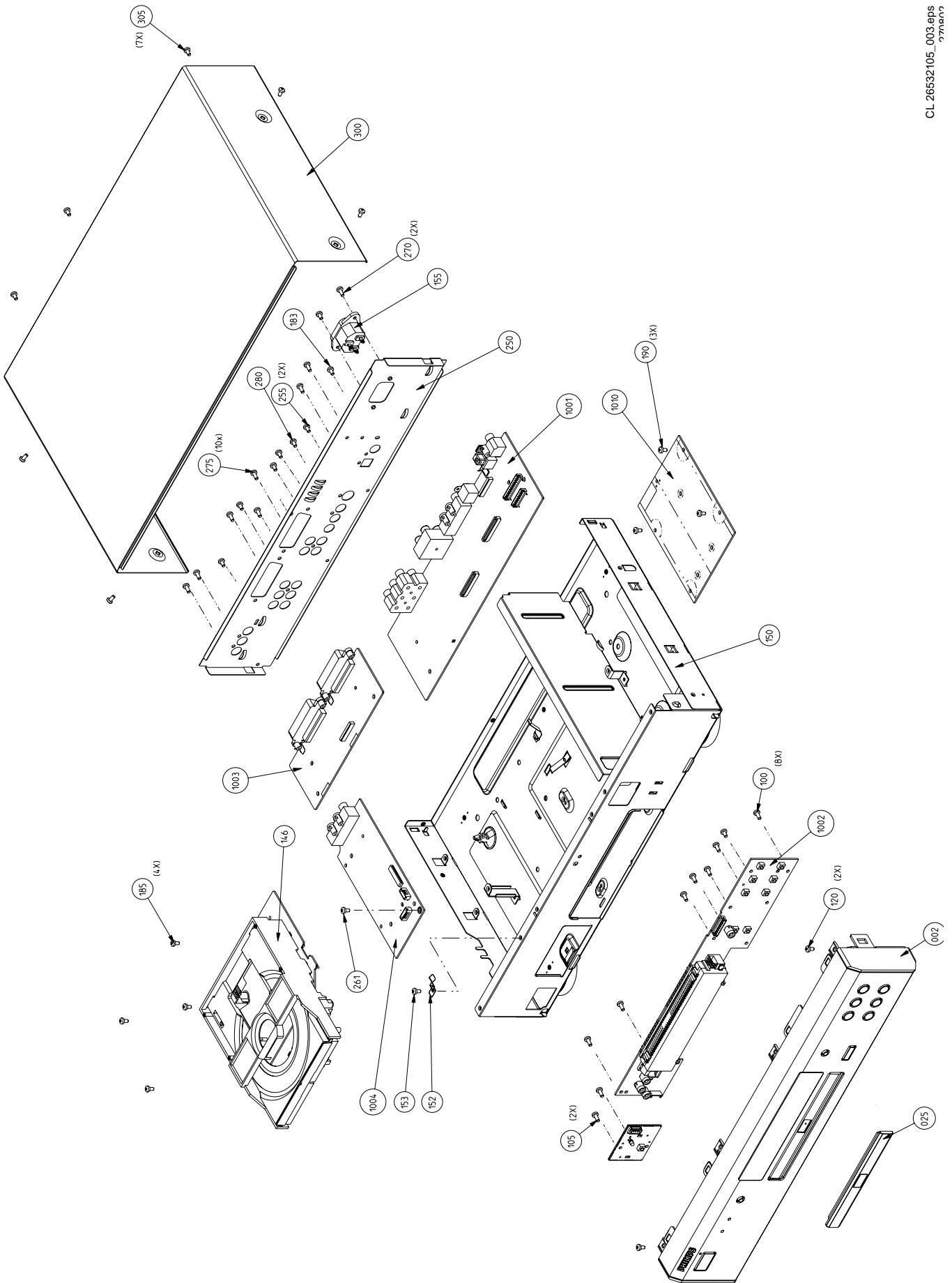

Figure 4-2 Exploded View

### 4.3 Service Hints

#### 4.3.1 Switched Mode Power Supply

The power supply unit has to be replaced in case of failure. The schematic provided in the manual is only for information and no service parts will be available.

#### 4.3.2 DVD Module

This module can be repaired as follows:

1. The VAL6011/14 is a combination of loading mechanism and DVD-mechanism. Both are not repairable units and in case of failure, it has to be replaced with a new loader VAL6011/14.

**Note:** When replacing with a new VAL6011/14, two solder joints have to be removed after connecting the OPU flex foil to the mono board.

The solder joints, which shortcircuits the laser diodes to ground, are for protection against ESD. Refer to figures 2-5 and 2-6 for location of solder joints.

2. The mono board has to be repaired down to component level. Repair handling of the monoboard requires a workshop with sophisticated desoldering tools.

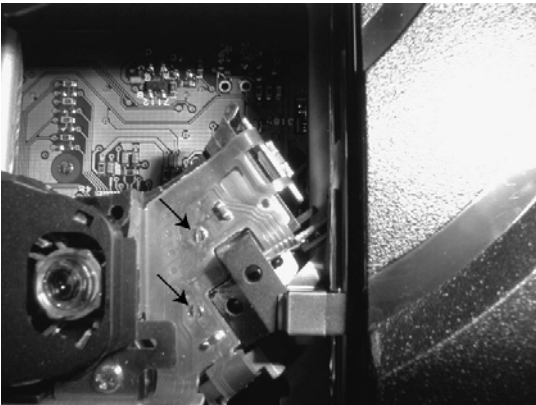

Figure 4-3 Solder joints

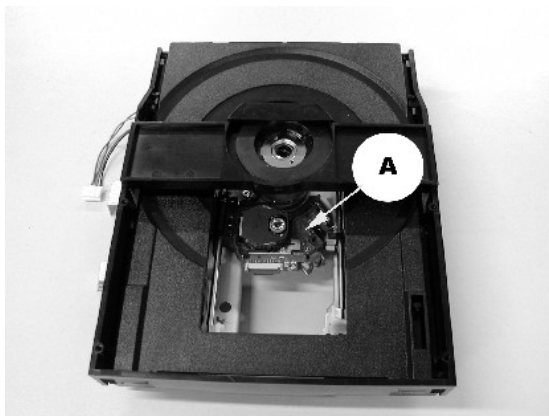

Figure 4-4 Solder joints

#### 4.3.3 ComPair

For assistance with the repair process of the monoboard an electronic fault finding guidance has been developed. This program is called ComPair.

This ComPair program is available on CDROM.

The version of the CDROM for repair of the monoboard is V1.3 or higher and can be ordered with codenumber 4822 727 21637. This is an update CDROM, so when the ComPair CDROM is used for the first time, one has to install the ComPair Engine CDROM V1.2 first.

The V1.2 CDROM can be ordered with code number 4822 727 21634 and has to be registered after installation. The procedure for registration is explained in the help file of the program and in the CDROM booklet.

The cable to connect the monoboard with a PC can be ordered with codenumber: 3122 785 90017.

All the hardware and software requirements of the systems, necessary for working with ComPair, are described on the CDROM.

#### 4.3.4 Service Positions

Refer to dismantling instructions for dismantling of the board. Figures 2-7 to 2-8 shows the service position that are recommended during repair of the boards.

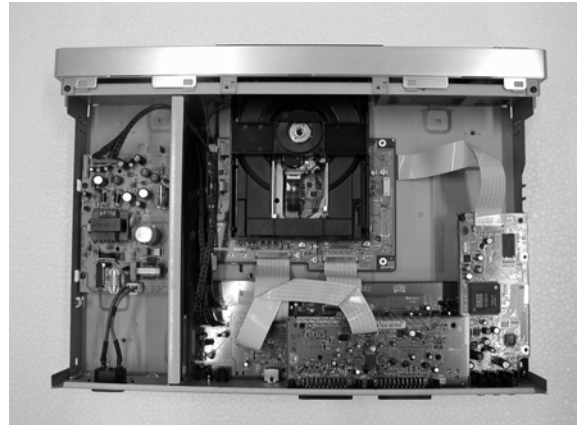

Figure 4-5 DVD963SA Layout

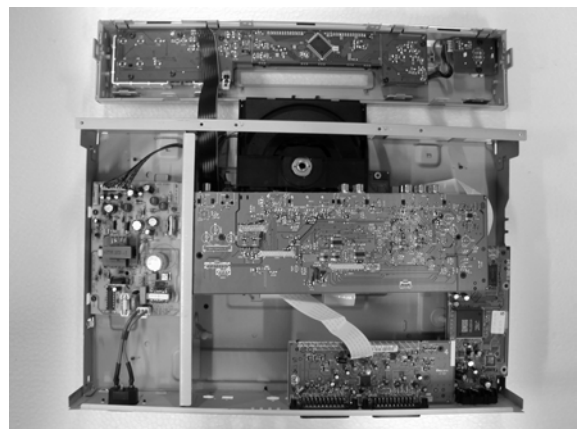

Figure 4-6 DVD963SA service manual

# 5. Diagnostic Software, Trouble Shooting and Test Instructions

## 5.1 Dealerscript

### 5.1.2 Contents of Dealer Script

#### 5.1.1 Purpose of Dealer Script

The dealer script can give a diagnosis on a standalone DVD player, no other equipment is needed to perform a number of hardware tests to check if the DVD player is faulty. The diagnosis is simply a "error" or "pass" message. No indication is given of faulty hardware modules. Only tests within the scope of the diagnostic software will be executed hence only faults within this scope can be detected.

The dealer script executes all diagnostic nuclei that do not need any user interaction and are meaningful on a standalone DVD player.

The nuclei called in the dealer script are the following (the number after each nucleus name corresponds with the number being on the local display when the nucleus is executed during the dealer script):

#### Nucleus

Display Countdown	Nucleus Number	Nucleus Name	Description
7	6	PapChksFl	Calculate and verify checksum of FLASH memory
6	12	PapI2cDisp	Checks the I2C interface with the slave processor on the display board
5	13	PapS2bEcho	Checks the I2C interface to the basic engine
4	11	PapI2cNvram	Checks the I2C interface with the NVRAM
3	15	PapNvramWrR	Pattern test of all locations in the NVRAM
2	16	CompSdramWrR	Pattern test of all locations in the SDRAM(s)
1	63	FURORERSdramWrRLow	Pattern test of all locations in the SDRAM(s)

CL 26532053\_052.eps  
150502

Figure 5-1 Dealer script nuclei

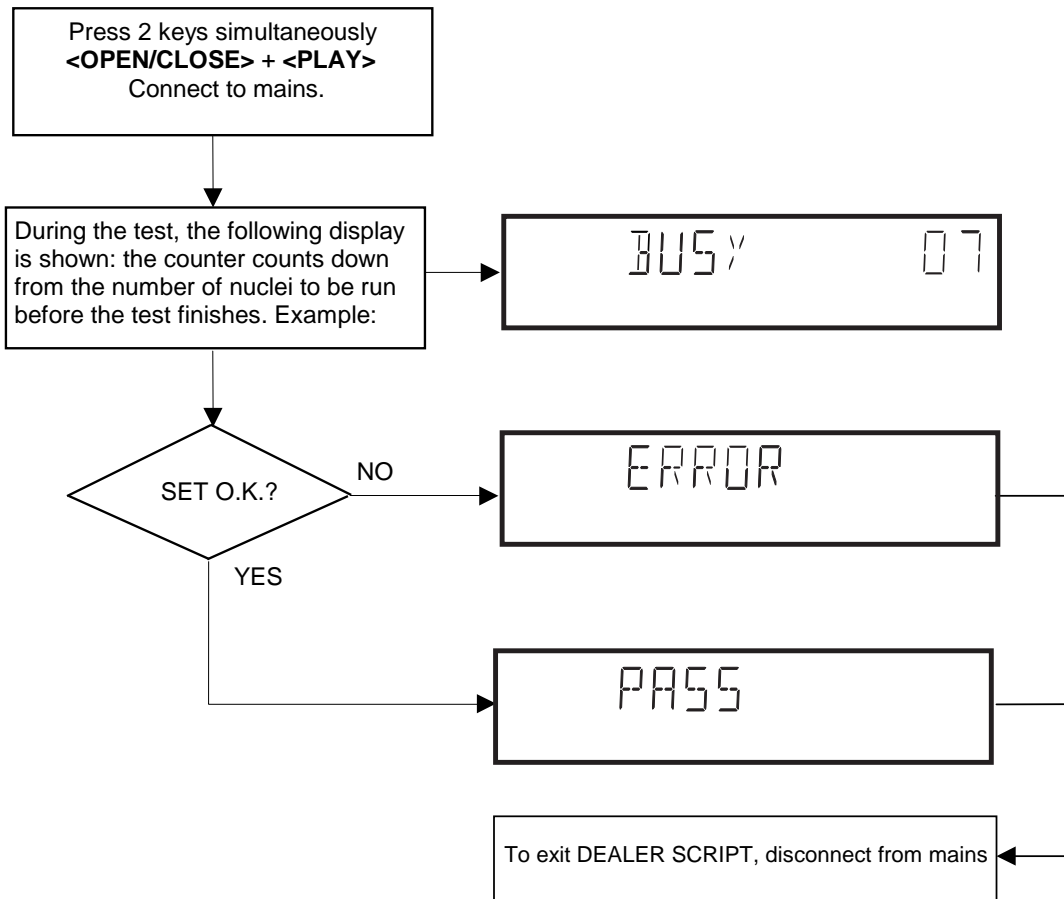

CL 26532053\_053.eps  
150502

Figure 5-2 Dealer Script

## 5.2 Player Script

Press the OPEN/CLOSE key to proceed to the next test.

### 5.2.1 Purpose of Player Script

The Player script will give the opportunity to perform a test that will determine which of the DVD player's modules are faulty, to read the error log and error bits and to perform an endurance loop test. To successfully perform the tests, the DVD player must be connected to a TV set to check the output of a number of nuclei. For DVDv2b a multi-channel amplifier, a set of 6 speakers and an external video source are necessary to test. To be able to check results of certain nuclei, the player script expects some interaction of the user (i.e. to approve a test picture or a test sound). Some nuclei (e.g. nuclei that test functionality of the Basic Engine module) require that the DVD player itself is opened, to enable the user to observe moving parts and approve their movement visually. Only tests within the scope of the diagnostic software will be executed hence only faults within this scope can be detected.

### 5.2.2 Contents of Player Script

The player script contains all nuclei that are useful on a DVD player that is connected to a TV set and help to determine which module of the DVD player is faulty, as well as to read out the contents of the error logs.

### 5.2.3 Structure of Player Script

The player script consists of a set of nuclei testing the three hardware modules in the DVD player: the Display PWB, the Digital PWB, and the Basic Engine. Nuclei run by the player test need some user interaction. In the next paragraph this interaction is described. The player test is done in two phases:

- Interactive tests:** this part of the player test depends strongly on user interaction and input to determine nucleus results and to progress through the full test. Reading the error log and error bits information can be useful to determine any errors that occurred recently during normal operation of the DVD player.
- The loop test:** this part of the player test will loop through the list of nuclei indefinitely, till the player is reset. The list of nuclei is as follows:
  - PapChksFlash
  - PapI2cNvram
  - CompSdramWrR
  - PapS2bEcho
  - PapI2cDisp

At the beginning of the tests, the DSW version number will be indicated on the local display of the DVD. The display will look like the following:

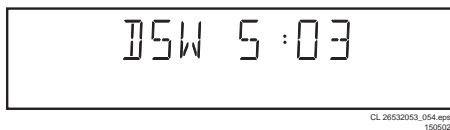

Figure 5-3

Pressing the PLAY key will proceed to the slave S/W version display, which is shown on the local display of the DVD player. The display will look like the following:

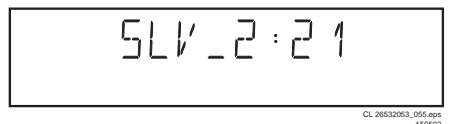

Figure 5-4

### 5.2.4 Survey

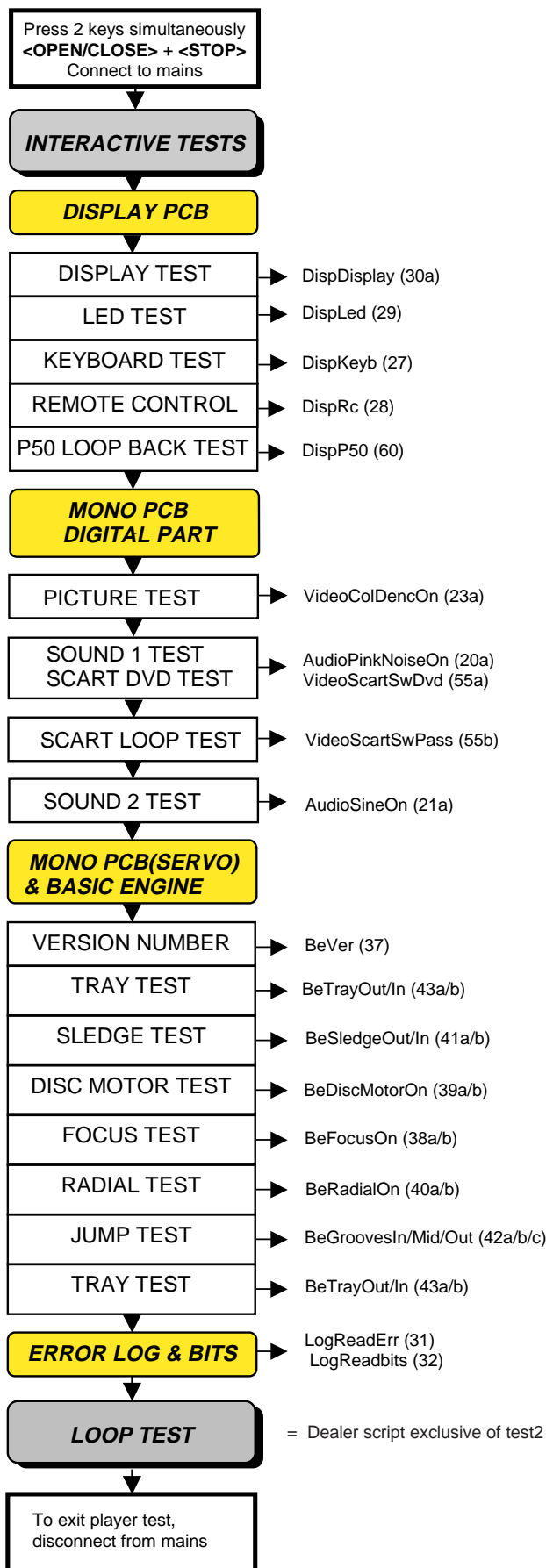

Figure 5-5

### 5.3 Display PCB

#### 5.3.1 Display Test

The display test is performed by nucleus DispDisplay. By putting a series of test patterns on the local display, the local display is tested. To step through all different patterns, the user must either press OPEN/CLOSE (pattern is ok) or STOP (pattern was incorrect) to proceed to the next pattern. The display of patterns is continued in a cyclic manner, shown in Fig. 5-6, until the user presses PLAY. If the user presses PLAY before all display patterns are tested, the DispDisplay nucleus will return FALSE (display test unsuccessful).

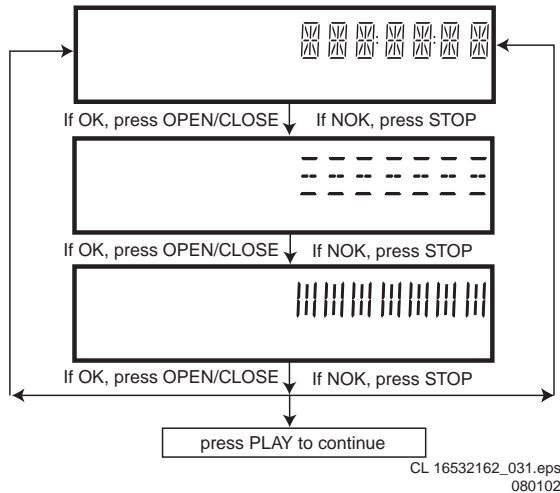

Figure 5-6

#### 5.3.2 LED Test

The LED(s) on the DVD player is (are) tested by nucleus DispLed. The user must check if the LED(s) is (are) lighted; if it is, press OPEN/CLOSE, if it is not, press STOP. By pressing PLAY the script will proceed to the next test. If the user presses PLAY before OPEN/CLOSE or STOP, the DispLed nucleus will return TRUE (LED test successful).

#### 5.3.3 Keyboard Test

The keyboard of the DVD player is tested by nucleus DispKeyb. The user is expected to press all keys on the local keyboard once. The code of the key pressed is shown on the local display (1 hexadecimal digit) immediately followed by a (hexadecimal) number indicating how many times that key has been pressed. Example of the local display during this test:

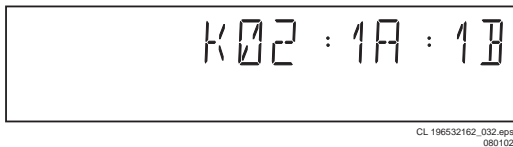

Figure 5-7

The key-codes displayed on the local display will scroll from right to left when the display gets full, the text "K" will remain on display.

KEY ID	KEY
0	PLAY
1	STOP
2	OPEN/CLOSE
3	STANDBY
4	NEXT
5	PREVIOUS
6	PAUSE
7	AUDIO DIRECT
E	SOUND MODE
F	REPEAT

CL 26532105\_057.eps  
300802

Figure 5-8

If any keys are detected more than once (due to hardware error), the key-code is displayed twice (or more), with the second digit increased by 1. If the user does not press all keys minimally once (in any order), the DispKeys nucleus will return FALSE and cause an error in the overall result of the player script. The user can leave the keyboard test by pressing the PLAY key on the local display of the DVD player for at least one full second. The result of the keyboard test is shown on local display as follows:

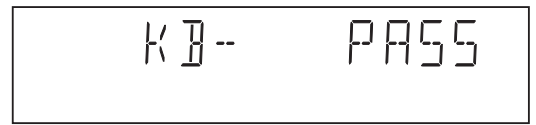

Figure 5-9

Or



Figure 5-10

Pressing PLAY on the local keyboard again will proceed to the next text.

#### 5.3.4 Remote Control Test

The remote control of the DVD player is tested by nucleus DispRc. The user must press any key on the remote control just once. The codes of the key pressed will be shown on the local display in hexadecimal format. Example:



Figure 5-11

In this example 23 is the hexadecimal code of the pressed RC key. The user can leave the remote-control test by pressing PLAY on the local keyboard of the DVD player. The remote control test is successful if a code was received before the user

pressed the PLAY key. Pressing the PLAY key, before pressing a key on the remote control, gives an error in the remote control test (note that the remote control test will also fail if a key on the remote control was pressed but no code was received). The remote control test does not check upon the contents of the received code, that is it will not be checked if the received code matches the key pressed. If desired, the user can manually check this code by using a code-table for the remote control key-codes.

RC Key id	Hexadecimal code
STANDBY	0C
1	1
2	2
3	3
4	4
5	5
6	6
7	7
8	8
9	9
0	0
RETURN	83
DISPLAY	EF
DISC MENU	54
SYSTEM MENU	82
CURSOR UP	58
CURSOR DOWN	59
CURSOR LEFT	5A
CURSOR RIGHT	5B
OK	5C
PREVIOUS	21
NEXT	20
STOP	31
PLAY	2C
PAUSE	30
SUBTITLE	4B
ANGLE	85
ZOOM	F7
AUDIO	4E
REPEAT	1D
REPEAT A-B	3B
SHUFFLE	1C
SCAN	2A

CL 16532162\_037.eps  
080102

Figure 5-12

After pressing PLAY, the result of the remote control test is displayed on the local display of the DVD player as follows:



Figure 5-13

Or

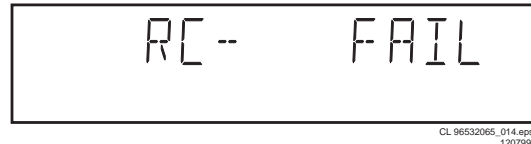

Figure 5-14

Pressing PLAY on the local keyboard again will proceed to the next test.

### 5.3.5 P50 Loop-Back Test

For the P50 loop-back test, the user must first press a key to decide if the test is to be performed. The display will show the following message:



Figure 5-15

If the user presses STOP, the P50 test will be skipped. If the user presses OPEN/CLOSE, the P50 test is performed and the result is displayed as follows:

Test successful:



Figure 5-16

Test fails:

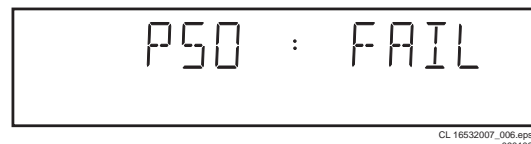

Figure 5-17

Press the PLAY key to continue to the next text



## 5.4 Mono PCB Digital Part

### 5.4.1 Picture Test

The picture test is performed by putting a predefined picture (colour bar) on the display (nucleus VideoColDencOn), and asking the user for confirmation.

The display will show the following message:

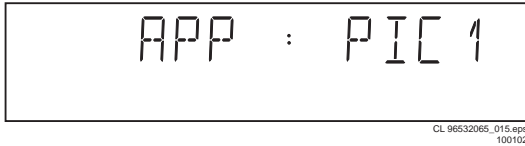

Figure 5-18

By pressing OPEN/CLOSE the user confirms the test, pressing STOP will indicate the picture was invisible or incorrect. Pressing PLAY will proceed to the next test. If the user presses PLAY without pressing OPEN/CLOSE or STOP first, the result of this test will be TRUE (picture ok).

**Note:** The colour bar must be simultaneously available on the CVBS, YC, and RGB (or YUV) outputs available. On the SCART only the CVBS and RGB signals will be available.

### 5.4.2 Sound 1 & SCART DVD Test

The first soundtest is performed by starting a pink noise sound that needs confirmation from the user (nucleus AudioPinkNoiseOn).

The display will show the following message:

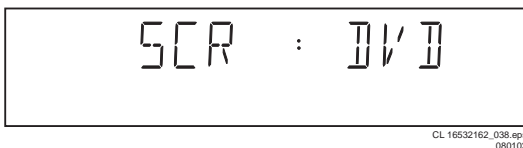

Figure 5-19

On the TV screen a colour bar (generated by nucleus VideoColDencOn) is visible and the internally generated pinknoise is audible.

By pressing the PLAY key, the user confirms the test. Pressing the STOP key will indicate the sound was inaudible or incorrect.

**Note:** Only for double scart models, SCART loop-through will be simultaneously active during this test. SCART loop-through will be measured with the aid of an external video source.

By pressing the PLAY key, there will be switched over to the external source. This must become now visible on the TV screen (using the SCART).

The local display will show the following message:

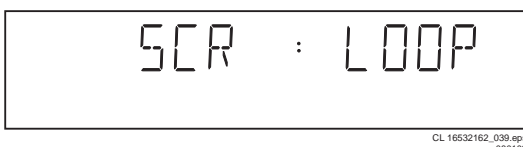

Figure 5-20

The internally generated colour bar is still available on the CVBS and Y/C outputs. And the pinknoise-signal is still available on the cinch audio outputs. By pressing the OPEN/CLOSE button, the internal generated colour bar becomes visual again.

The test can be left by pressing the PLAY key for more than one second.

### 5.4.3 Sound 2 Test

The second soundtest is performed by producing a sine sound (nucleus AudioSineOn). The signal can be stopped by pressing the STOP key.

The display will show the following message:

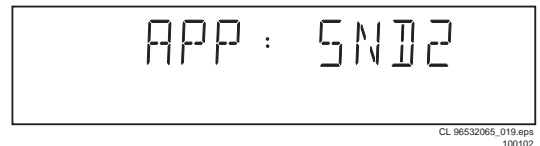

Figure 5-21

After the audio signal has been stopped, by pressing OPEN/CLOSE, the user confirms the test. Pressing STOP will indicate that something went wrong. Pressing PLAY will proceed to the next. If the user presses PLAY without pressing OPEN/CLOSE or STOP first, the result of this test will be TRUE (sound ok).

## 5.5 Basic Engine

### 5.5.1 Version Number

In the basic engine tests, the version number of the Basic Engine will be shown first, as the following example:

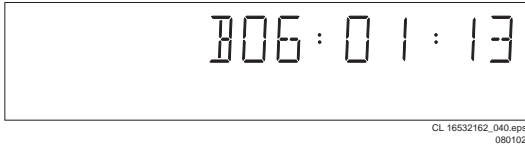

Figure 5-22

By pressing the PLAY key, the Basic Engine tests are started.

### 5.5.2 Tray Test

First, the tray is tested. The purpose of this test is also to give the user the opportunity to put a disc in the tray of the DVD player. Some tests on the Basic Engine require that a disc (e.g. DVD MPTD test disc) is present in the player. At the end of the Basic Engine tests this tray test will be repeated solely to enable the user to remove the disc in the tray. The local display will look as follows:

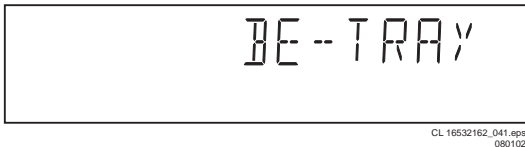

Figure 5-23

By pressing OPEN/CLOSE the user can toggle the position of the tray. Note that this test will not contribute to the test result of the Basic Engine. Pressing PLAY will proceed to the next test. At this point, the tray will be closed automatically by the software if it was open.

### 5.5.3 Sledge Test (Visual Test)

The second Basic Engine test tests the sledge. The user can move the sledge as many times as desired by using OPEN/CLOSE (nucleus BeSledgeOut) and STOP (nucleus BeSledgeIn). Pressing PLAY on the local keyboard proceeds to the next test. Note that this test will not contribute to the test result of the Basic Engine.

The local display will look as follows during the sledge test:

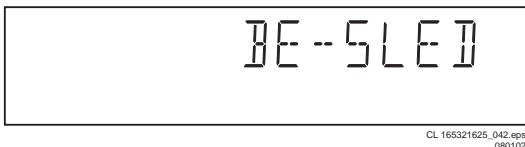

Figure 5-24

### 5.5.4 Disc Motor Test (Visual Test)

The third Basic Engine test tests the disc motor (nucleus BeDiscMotorOn).

The local display looks as follows:

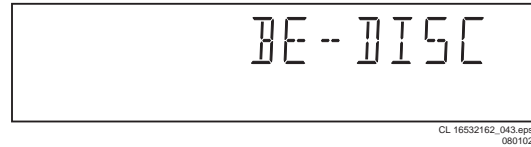

Figure 5-25

By pressing OPEN/CLOSE the user confirms that the disc motor is running. Pressing STOP indicates the disc motor does not work. Pressing PLAY proceeds to the next test, after a reset of the disc motor (nucleus BeDiscMotorOff). If the user presses PLAY before pressing OPEN/CLOSE or STOP, the result of this test will be TRUE (disc motor is running).

### 5.5.5 Focus Test (Visual Test)

The fourth Basic Engine test tests the focussing. First focussing is turned on by calling nucleus BeFocusOn. The display will look as follows:

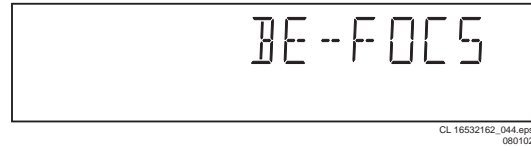

Figure 5-26

By pressing OPEN/CLOSE the user confirms that the focussing was successful. Pressing STOP indicates a focussing failure. Pressing PLAY proceeds to the next test after a reset of the focussing (nucleus BeFocusOff). If PLAY is pressed before OPEN/CLOSE or STOP, the result of this test will be TRUE (focus successful).

### 5.5.6 Radial Test (Visual & Listening Test)

The fifth Basic Engine test tests the radial functionality (nucleus BeRadialOn).

The local display looks as follows:

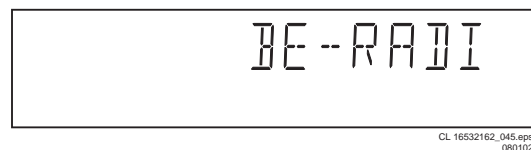

Figure 5-27

By pressing OPEN/CLOSE the user confirms that the radial function works. Pressing STOP indicates the function does not work. Pressing PLAY proceeds to the next test, after a reset of the radial (nucleus BeRadialOff). If the user presses PLAY before pressing OPEN/CLOSE or STOP, the result of this test will be TRUE (radial successful).

### 5.5.7 Jump Test (Listening Test)

The sixth and last Basic Engine test tests the jumping by calling nuclei BeGroovesIn, BeGroovesMid and BeGroovesOut. During this test, the local display looks as follows:

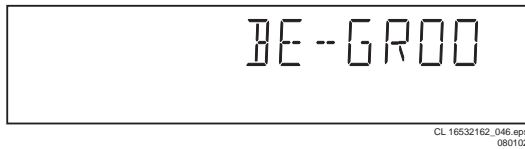

Figure 5-28

The user can switch between the three different types of groove settings by pressing OPEN/CLOSE (forward to next nucleus in the list In-Mid-Out), or STOP (backward in the list In-Mid-Out). This is done in a cyclic manner; note that this test will not contribute to the test result of the Basic Engine. Pressing PLAY proceeds to the next test, after the disc motor has been shut off with a call to nucleus BeDiscMotorOff.

### 5.5.8 Tray Test

As a last action for the Basic Engine tests, the tray test is repeated. The local display will look as follows:

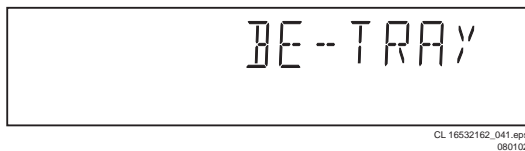

Figure 5-29

This test is meant to give the user the opportunity to remove the disc in the tray. The tray position can be toggled using the OPEN/CLOSE key. The tray will be closed (by the software, if it is open) before proceeding to the next test when the user presses the PLAY key.

### 5.5.9 Error Log (See Table on Page 25)

Reading the error log and error bits information can be useful to determine any errors that occurred recently during normal operation of the DVD player. Reading the error log is done by nucleus LogReadErr.

The display during the errorlog readout looks as follows :

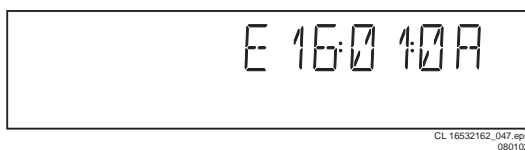

Figure 5-30

**Note:** Previous versions of the diagnostic software showed a 8-digit error code.

Due to limitations in the number of digits that can be displayed by some front panel displays, the most significant digits will not be shown. This can be done since all the error codes used by this player has set these 2 digits to "00"

By pressing OPEN/CLOSE or STOP the user can move forward or backward (respectively) through the logged error codes. If "0000" is displayed at all positions, the error log is empty. Display of the logged errors is done in a cyclic manner. By pressing PLAY on the local keyboard, the user can proceed to the next test.

### 5.5.10 Error Bits

Reading the error bits is done by nucleus LogReadBits. The display during the errorbits readout looks as follows:

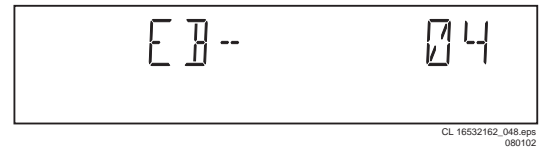

Figure 5-31

Only the identification number (decimal) representing set errorbits will be shown. By pressing OPEN/CLOSE or STOP, the user can move forward or backward (respectively) through the logged errorcodes. If the display only shows "EB-0", no error bits were set. By pressing PLAY the user can continue to the next test.

## 5.6 Loop Test (See Table Below)

At the start of the loop test, the local display of the DVD player will show the interactive player test result readout in the following display:

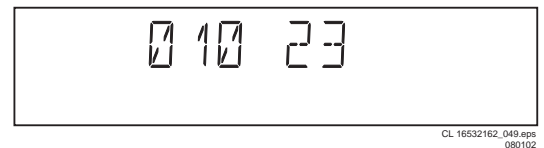

Figure 5-32

The left side of the display contains a 3-digit code, which can have a value between 000 and 111. These values indicate the faulty modules and are to be interpreted as follows:

Displayed Value	Indication for each module		
	Basic Engine	Mono PCB	Display PCB
000	ok	ok	ok
001	ok	ok	faulty
010	ok	faulty	ok
011	ok	faulty	faulty
100	faulty	ok	ok
101	faulty	ok	faulty
110	faulty	faulty	ok
111	faulty	faulty	faulty

CL 96532065\_031.eps  
120799

Figure 5-33

The loop test will perform the same nuclei as the dealer test, but it will loop through the list of nuclei indefinitely. The display of the DVD player will display not only the three digits indicating correct/faulty modules and the last found error code (as mentioned, faults are detected as far as they can be within the scope of the diagnostic software), but also a loop counter indicating how many times the loop has been gone through. If an error was detected, the display will remain as in figure 5-34 until the user presses the PLAY key and then it will continue to the next loop.

Example:

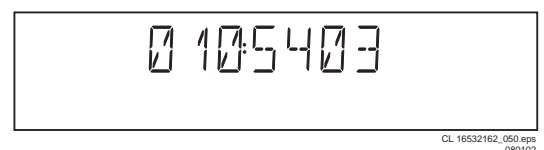

Figure 5-34

The 2-digit number (23) on the right of figure 5-32 indicates the number of times the loop test has been performed.

**After one loop cycle:** Display the 3-digit module bits together with the last error code which occurred in the loop test. The 4 digits at the right side of the display (fig. 5-34) show the last error that was found during the loop test. The leftmost two digits (54) of this code indicates which nucleus resulted in a fault. The rightmost two digits (03) refer to the faultcode within that nucleus. For further explanation of this error code, refer to chapter 5.8 (Nuclei Error Codes).

### 5.6.1 Errorlog

#### Explanation:

The application errors will be logged in the NVRAM. The maximum number of error bytes that will be visible is 16. The first word (4 digits) of the byte is the component identification, the last word is the error code.

The diagnostics software will present a combination of this component identification plus an error code on the local display (and on the attached terminal). The last reported error is shown as < 00000000, the oldest visible error as 00000000 > and the errors in between as < 00000000 >.

The devices that may report errors are the serial controller (UART), the basic engine (BE), the slave processor (SLPH), the SACD Stream Manager (SSM) and the SACD Media Access (SMA). The identification of these components is as follows:

Component name	Component identification
Serial controller (UART)	000A
Engine (BE)	0016
Slave Processor (SLPH)	001A
SACD Stream Manager (SSM)	001C
SACD Media Access (SMA)	002E
Diagnostic software (DS)	Dxxx

The tables in the next chapters list the error code and corresponding problem. The column 'Explanation' holds a more elaborate description and the most likely reason for the error.

#### Some Examples:

002E0000 (SMA reported a timeout error)  
 0016010A (Engine could not fully close or open the tray)  
 D0010001 (Flash checksum failed).

For further explanation of DS errors, see description of nuclei error codes in paragraph 5.8.

#### UART Error Codes

Error Number	Error name	Explanation
0000	BUF_OVE RFLOW	To many characters were offered in too little time. Reason: system was too busy doing other jobs.
0001	COMMUNI CATION	Usually a protocol error. Reason: bad connection between engine and processor.
0002	TIME OUT	

#### BE Errors

Error Number	Error name	Explanation
0101	S2B_ILL_CO MMAND	Parameter(s) not valid for this command. Reason: some communication problem between UART and engine.
0102	S2B_ILL_PAR AM	Command not allowed in this state or unknown. Reason: see S2B_ILL_COMMAND error

Error Number	Error name	Explanation
0103	S2B_SLEDGE	Sledge could not be moved to home position.
0104	S2B_FOCUS	Focus failure
0105	S2B_MOTOR	Motor could not reach speed within timeout
0106	S2B_RADIAL	Servo didn't get on track after several retries.
0107	S2B_PLL_LO CK	PLL could not lock in Accessing or Tracking state
0108	SBC_HEADE R_TO	Header timeout
0109	S2B_SBC_NO T_FOUND	Requested subcode item could not be found.
010A	S2B_TRAY	Tray could not be opened or closed completely.
010B	S2B_TOC_RE AD	TOC could not be read within timeout period.
010C	S2B_JUMP	Requested seek could not be performed.
010D	S2B_NON_EX IST_SES	Attempt to access a non-existing session.
010E	S2B_NON_EX IST_BCA	Caller tries to acces a non-existing BCA area
010F	Speed setting	A wrong or inappropriate speed value has been set
0116	NO_DISC	No disc selected
011A	TRAY_INIT	After reset, initialized tray
011B	NO TOC INFO	No TOC information in lead-in area or erase TOC found
01F0	S2B_OVERR UN	Too many bytes received over S2B Reason: see S2B_ILL_COMMAND error
01F1	S2B_COMM_ TO	Not enough bytes are received over S2B Reason: see S2B_ILL_COMMAND error
01F2	S2B_PARITY	Byte received with parity error. Reason: see S2B_ILL_COMMAND error
01F3	S2B_ILL_PHA SE	CMD IDC is not valid, transmission out of sync. Reason: see S2B_ILL_COMMAND error
01F4	S2B_ILL_NR_ OF_BYTES	Byte count has an illegal value. Reason: see S2B_ILL_COMMAND error

#### SLPH Error Codes

Error Number	Error name	Explanation
0000	COMMUNICA TION	Error in I2C communication. Reason: bad connection between slave processor and main processor.

#### SSM Error Codes

Error Code	Error name	Explanation
0006	SP_SYNCER ROR	System cannot get synchronised with sectors coming from disc. Reason: Usually a damaged disc or the player was dropped/pushed during operation. If not, the engine is malfunctioning.
0007	SP_EDCERR OR	Data coming from disc is damaged. Reason: see SP_SYNCERROR

Error Code	Error name	Explanation
0008	SP_CONTINUITYERROR	Sequence of sectors coming from disc is incorrect. Reason: see SP_SYNCERROR
0009	DMX_CONTINUITYERROR	Sequence of sectors is incorrect. Reason: problem with buffer RAM
000A	LLD_ERROR	An illegal audio format was offered to the decoder. Reason: unknown audio type on disc or problem with buffer RAM
000B	BCU_ERROR	Internal problem in Furore chip

**SMA Error Codes**

Error Number	Error name	Explanation
0000	SMA_TIMEOUTERROR	Data coming from disc not in time. Reason: damaged disc or engine problem.

**5.6.2 Reprogramming of New Mono Boards.****Caution**

***This information is confidential and may not be distributed. Only a qualified service person should reprogram the mono board.***

After reset of NV-memory or repair of the mono board, all the customer settings and also the region code will be lost.

Reprogramming of the mono board will put the player back in the state in which it has left the factory, i.e. with the default settings and the allowed region code.

Reprogramming is limited to 25 times

When the counter reaches 25, reprogramming is not possible anymore

Reprogramming will be done by way of the remote control.

Put the player in stop mode, no disc loaded.

Press the following keys on the remote control:

<PLAY> followed by numerical keys <1> <5> <9>

The display shows: “-----”

Press now successively the following keys :

for DVD963SA /001 : <2><2><2> <0><1><2><0><0>

for DVD963SA 171 : <1><1><1> <0><1><0><0><0>

for DVD963SA 691 : <3><2><3> <0><1><0><0><0>

Press <PLAY> again.

The TV screen will become BLUE during a short time to confirm that the mono board has been reprogrammed.

Figure 5-35 Reprogramming code

5.6.3 Trade Mode

**When the player is in Trade Mode, the player cannot be controlled by means of the front key buttons, but only by means of the remote control.**

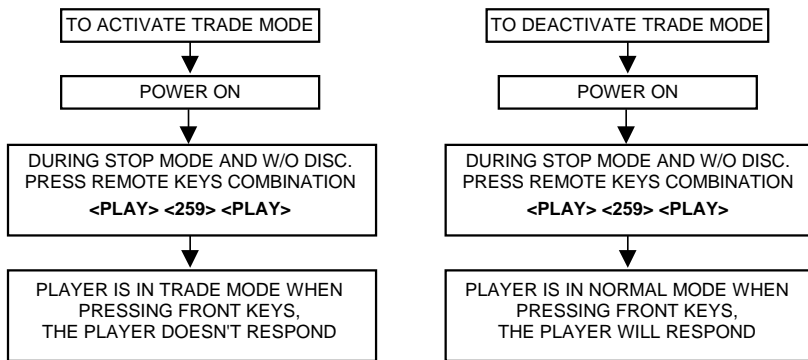

CL16532162\_052.eps  
0850102

Figure 5-36

**Note:** To activate and deactivate the Trade Mode with the disc in the player, the procedure is similar to above, except that the remote control keys combination is pressed at the instant when the local display is flashing "READING"

5.7 Menu and Command Mode Interface

5.7.1 Layout of Results Diagnostic Nuclei

Results returned from a Diagnostic Nucleus will be displayed in the following layout:  
< number >< string > [ok | ER]

< number >: is a 4-digit decimal number padded with leading zeros if its value is less than 4 digits. The first 2 digits identify the generating nucleus (or group of nuclei) while the latter 2 digits indicate the error number.

< string >: is a text string containing information about the result of the Diagnostic Nucleus.

< number > and < string > are defined in [SSD\_DN] in the output sections of each Nucleus.

Examples:

1. 0001Unknown command ER @
2. 3100OK @
3. 0901Data line X is not connected to the DRAM ER @

5.7.2 Command Mode Interface

**Set-up Physical Interface Components**

Hardware required:

- Service PC
- one free COM port on the Service PC
- special cable to connect DVD player to Service PC

The service PC must have a terminal emulation program (e.g. OS2 WarpTerminal or Procomm) installed and must have a free COM port (e.g. COM1). Activate the terminal emulation program and check that the port settings for the free COM port are: 19200 bps, 8 data bits, no parity, 1 stop bit and no flow control. The free COM port must be connected via a special cable to the RS232 port of the DVD player. This special cable will also connect the test pin, which is available on the connector, to ground (i.e. activate test pin).

Code number of PC interface cable: 3122 785 90017

**Activation**

Switch the player on and the following text will appear on the screen of the terminal (program):

```
DVDv4 Diagnostic Software version 5.03
(M)enu, (C)ommand or (S)2B interface ? [M]:@ C <enter>

SDRAM Interconnection test passed
Basic SDRAM test passed
Slave Processor: SLAVE2

DD:> CL 26532105_058.eps 020902
```

Figure 5-37

The first line indicates that the Diagnostic software has been activated and contains the version number. The second line lets the user choose the interface format. Enter 'C' to select Command Mode and the next three lines are the successful result of the two subsequent basic tests (nuclei 2, 4 and the detection of the display type used by the panel respectively). If not all these messages appear on the terminal screen, then the related nucleus found an error. The last line is the prompt ("DD>"). The diagnostic software is now ready to receive commands.

**Command Overview of Nuclei**

The following table gives an overview of all available nuclei. The first column contains an identification number, the second contains the name of a nucleus and the last column indicate the description of the nucleus.

**Note:** User confirmation is necessary during front panel tests

Table 5-1 Basic diagnostic nuclei

Ref. #	Reference Name	Remark
1	BasicSpAcc	Serial port Access test/ initialization
2a	BasicInterconDram	Data and address bus Interconnection (only for development)
2b	BasicInterconSdram	Data and address bus interconnection
3	BasicDramWrR	DRAM Write Read (only for development)
4	BasicSdramWrR	SDRAM Write Read

Table 5-2 Processor and peripherals

Ref. #	Reference Name	Remark
6	PapChksFl	Checksum FLASH
7a	PapUclkAclkCdda	uClock A_CLK in CD-DA mode
7b	PapUclkAclkDvd	uClock A_CLK in DVD mode
7c	PapUclkAclkDvd96	uClock A_CLK in DVD (96kHz) mode
10	PapFlashWrAcc	FLASH Write Access (only for development)
11	PapI2cNvram	I2C NVRAM access
12	PapI2cDisp	I2C Display PWB
13	PapS2bEcho	S2B Echo
14	PapS2bPass	S2B Pass-through
15	PapNvramWrR	NVRAM Write Read
62	PapChksSum	Show checksums stored in flash

Table 5-3 Components

Ref. #	Reference Name	Remark
16	CompSdramWrR	SDRAM Write Read

Table 5-4 Audio

Ref. #	Reference Name	Remark
19a	AudioMuteOn	Audio Mute On
19b	AudioMuteOff	Audio Mute Off
20a	AudioPinkNoiseOn	Audio Pinknoise On
20b	AudioPinkNoiseOff	Audio Pinknoise (or beep tone) Off
20c	AudioBeepToneOn	Audio Beep Tone On
21a	AudioSineOn	Audio Sine signal On/Off
21b	AudioSineBurst	Audio Sine signal Burst
56a	AudioLfePortHigh	Set the LFE_SEL port to HIGH
56b	AudioLfePortLow	Set the LFE_SEL port to LOW
66a	DAC_I2C	Resets DAC and check I2C communication with DAC
66b	DAC_I2CEnable	Enable I2C communication to AV board
66c	DAC_I2CDisable	Disable I2C communication to AV board
67a	DAC_ClockInternal	Uses internal clock from monoboard for DAC (256fs)
67b	DAC_ClockExternal	Uses external clock for DAC (384fs)
68a	DAC_AudioPreMuteOn	Enable Audio Pre-mute pin
68b	DAC_AudioPreMuteOff	Disable Audio Pre-mute pin
69a	DAC_CenterOn	Enable Center on pin
69b	DAC_CenterOff	Disable Center on pin
79	DAC_Reset	Resets DAC
80a	DAC_ModeCDDA	Sets DAC to CDDA mode
80b	DAC_ModeDVD48	Sets DAC to DVD mode (48kHz)
80c	DAC_ModeDVD96	Sets DAC to DVD mode (96kHz)

Ref. #	Reference Name	Remark
80d	DAC_ModeDSD	Sets DAC to DSD mode
81a	DAC_LowPowerStandbyOn	Enable Low Power Standby
81b	DAC_LowPowerStandbyOff	Disable Low Power Standby
82a	DAC_UpsamplingFreq192k	Sets Upsampling frequency to 192kHz
82b	DAC_UpsamplingFreq96k	Sets Upsampling frequency to 96kHz
82c	DAC_UpsamplingOn	Enable upsampling
82d	DAC_UpsamplingOff	Disable upsampling

Table 5-5 Video

Ref. #	Reference Name	Remark
17a	VidPortOutAA	Output the value 0XAA at the Digital Video Interface Port
17b	VidPortOut55	Output the value 0X55 at the Digital Video Interface Port
23a	VideoColDencOnPAL	Colourbar (PAL) DENC On
23b	VideoColDencOff	Colourbar DENC Off
23c	VideoColDencOnNTSC	Colourbar (NTSC) DENC On
24a	VideoProgMPEGon	Progressive - DigitalVideo Colour Bar ON
24b	VideoYuvMPEGon	Enhanced YUV-DigitalVideo Colour Bar
25a	VideoScartLo	Scart Low
25b	VideoScartMi	Scart Medium
25c	VideoScartHi	Scart High
54	VideoScartSwComm	Scart Switch communication
55a	VideoScartSwDvd	Scart Switch Dvd
55b	VideoScartSwPass	Scart Switch Pass-through
57a	VideoScartPinLo	PIO-pins as used in 2A for Scart-switching
57b	VideoScartPinMi	PIO-pins as used in 2A for Scart-switching
57c	VideoScartPinHi	PIO-pins as used in 2A for Scart-switching
61a	VideoColOutRGB (ST5508)	Output RGB from ST5508
61b	VideoColOutYUV (ST5508)	Output YUV from ST5508

Table 5-6 Display (slave processor)

Ref. #	Reference Name	Remark
26	DispVer	Version number
27	DispKeyb	Keyboard
28	DispRc	Remote Control
29	DispLed	LEDs
30a	DispDisplay	VFT Display test
30b	DispLCDisplay	LCD Display test
30c	DispLCDBkLight	LCD Backlight test
60	DispP50	P50 loopback test

Table 5-7 Log (Error logging in Nvram)

Ref. #	Reference Name	Remark
31	LogReadErr	Read last Errors
32	LogReadBits	Read errors Bits
33	LogReset	Reset

Table 5-8 Miscellaneous

Ref. #	Reference Name	Remark
34	MiscReadConfig	Read Configuration area from NVRAM
35	MiscNvramReset	NVRAM Reset
36	MiscNvramMod	Modify NVRAM contents
46	MiscAppVer	Read version of application software
47a	MiscTrayOpenNr	Read the number of times the tray opened
47b	MiscPowerOnTime	Read the total time the player's power has been on
47c	MiscPlayTimeCddaVcd	Read the Playtime of CDDA and VCD discs
47d	MiscPlayTimeDvd	Read the Playtime of DVD discs

Table 5-9 Basic engine

Ref. #	Reference Name	Remark
37	BeVer	Version number
38a	BeFocusOn	Focus On
38b	BeFocusOff	Focus Off
39a	BeDiscmotorOn	Discmotor On
39b	BeDiscmotorOff	Discmotor Off
40a	BeRadialOn	Radial control On
40b	BeRadialOff	Radial control Off
41a	BeSledgeIn	Sledge Inwards
41b	BeSledgeOut	Sledge Outwards
42a	BeGroovesIn	jump Grooves to Inside
42b	BeGroovesMid	jump Grooves to Middle
42c	BeGroovesOut	jump Grooves to Outside
43a	BeTrayIn	Tray In
43b	BeTrayOut	Tray Out
44	BeReset	Reset Basic Engine
58a	LaserCdOn	CD Laser on
58b	LaserCdOff	CD Laser off
58c	LaserDvdOn	DVD Laser on
58d	LaserDvdOff	DVD Laser off
70	BedReadFlashID	Read flash memory manufacturer and device ID
71	BedCalcRomChecksum	Calculate ROM checksum
72	BedScratchTest	Test scratch detection circuit

Table 5-10 Furore IC

Ref. #	Reference Name	Remark
63	Furore_SdramWrR	Furore SDRAM Write Read test
64	Furore_SdramWrR Fast	Furore SDRAM interconnection test
65	Furore_Id	Furore version ID check
83	Furore_Reset	Furore reset

Ref. #	Reference Name	Remark
84a	Furore_High	Sets Furore output pins DSD_PCM0-9 to high
84b	Furore_Low	Sets Furore output pins DSD_PCM0-9 to low

Table 5-11 Karaoke (not available)

Ref. #	Reference Name	Remark
48a	KaraokeModeOff	Switch Karaoke mode off
48b	KaraokeModeOn	Switch Karaoke mode on
49	KaraokeMicInput	Check path from the microphone input to audio output
50a	KaraokeKeyOn	Set Karaoke Key to the maximum level (1200 cent)
50b	KaraokeKeyOff	Set Karaoke Key to flat octave (0 cent)
51a	KaraokeEchoOn	Set Echo Control function on
51b	KaraokeEchoOff	Set Echo Control function off

### 5.7.3 Menu Mode Interface

#### Activation

Switch the player on and the following text will appear on the screen of the terminal (program):

```
DVDv4 Diagnostic Software version 5.03

(M)enu, (C)ommand or (S)2B interface ? [M]:e <enter>
SDRAM Interconnection test passed
Basic SDRAM test passed
Slave Processor: SLAVE2

Press ENTER to go to main menu
CC: > <enter>

MAIN MENU
1. Audio ...
2. Video ...
3. Front Panel ...
4. Basic Engine ...
5. Processor Peripherals ...
6. Error Log ...
7. Furore ...
8. Miscellaneous ...

Select > CL 26532105_059.eps
020902
```

Figure 5-38 Screen menu

The first line indicates that the Diagnostic software has been activated and contains the version number. The next lines are the successful result of the SDRAM interconnection test and the basic SDRAM test. The last line allows the user to choose between the four possible interface forms. If pressing M has made a choice for Menu Interface, the Main Menu will appear.

#### Layout of Menu and Submenu

The following menu layout will appear after starting up the DVD player in menu mode. The symbol "- -" indicates that the current menu choice will invoke the display of a submenu. The number between [ ] indicates the nucleus number. These numbers will not be shown on the screen.

#### Menus

##### MAIN MENU

- 1 Audio...
- 2 Video...
- 3 Front Panel...



- 4 Basic Engine...
- 5 Processor Peripherals...
- 6 Error Log...
- 7 Furore...
- 8 Miscellaneous...

**First Level Submenus****MAIN > AUDIO MENU**

- 1 Mute...
- 2 Pink Noise...
- 3 Sine Wave...
- 4 Digital Ports...
- 5 Ext. DAC Board...

**MAIN > VIDEO MENU**

- 1 Colourbar...
- 2 Scart...
- 3 Digital Port...

**MAIN > FRONT PANEL MENU**

- 1 Slave Processor...
- 2 VFT Display [30a]
- 3 LCD Display [30b]
- 4 LCD BkLight [30c]
- 5 Keyboard [27]
- 6 LEDs [29]
- 7 Remote Control [28]
- 8 P50 Check [60]

**MAIN > BASIC ENGINE MENU**

- 1 Reset [44]
- 2 Version [37]
- 3 S2B...
- 4 Loader Mechanism...
- 5 Special Diagnostics...

**MAIN > PROCESSOR PERIPHERALS MENU**

- 1 Clock...
- 2 Flash...
- 3 NVRAM...
- 4 SDRAM Write/Read [16]

**MAIN > ERROR LOG MENU**

- 1 Read Last Errors [31]
- 2 Read Error Bits [32]
- 3 Reset Error Log [33]

**MAIN > FURORE MENU**

- 1 SDRAM Write/Read [63]
- 2 SDRAM Write/Read [64]
- 3 Chip Revision ID [65]
- 4 Set DSD\_PCM Output High [84a]
- 5 Set DSD\_PCM Output Low [84b]
- 6 Reset Furore IC [83]

**MAIN > MISCELLANEOUS MENU**

- 1 Statistics Info...
- 2 Read DVD Application version[46]

**Second Level Submenus****MAIN > AUDIO > MUTE MENU**

- 1 Mute On [19a]
- 2 Mute Off [19b]
- 3 Mute Front LR On (963 only) [19c]
- 4 Mute Front LR Off (963 only) [19d]

**MAIN > AUDIO > PINK NOISE MENU**

- 1 Pink Noise On [20a]
- 2 Pink Noise / Beep Tone Off [20b]
- 3 Beep Tone On [20c]

**MAIN > AUDIO > SINE WAVE MENU**

- 1 Audio Sine On [21a]
- 2 Audio Burst On [21b]

**MAIN > AUDIO > DIGITAL PORTS MENU**

- 1 No tests available

**MAIN > AUDIO > EXT DAC BOARD MENU**

- 1. DAC Reset [79]
- 2. I2C Test...
- 3. Clock...
- 4. Audio...
- 5. Low Power Standby...
- 6. DAC Mode...

**MAIN > VIDEO > COLOURBAR MENU**

- 1 Colourbar DENC On (PAL) [23a]
- 2 Colourbar DENC On (NTSC) [23c]
- 3 Colourbar DENC/MPEG Off [23b]
- 4 ProgressiveScan MPEG On [24a]
- 5 Enhanced YUV MPEG On [24b]
- 6 Set Video Out To RGB [61a]
- 7 Set Video Out To YUV [61b]

**MAIN > VIDEO > SCART MENU**

- 1 I2C Scart IC Check [54]
- 2 Scart To DVD [55a]
- 3 Scart Pass Through [55b]
- 4 Scart Pin 8 Low (0 to 2)V [25a]
- 5 Scart Pin 8 Mid (4.5 to 7)V [25b]
- 6 Scart Pin 8 Hi(9.5 to 12)V [25c]

**MAIN > VIDEO > DIGITAL PORT MENU**

- 1 Video Port Out 0xAA [17a]
- 2 Video Port Out 0x55 [17b]
- 3 P-scan board IO exp [17c]

**MAIN > FRONT PANEL > SLAVE PROCESSOR MENU**

- 1 Bus Comms Check [12]
- 2 S/W Version [26]

**MAIN > BASIC ENGINE > S2B MENU**

- 1 S2B Echo [13]
- 2 S2B Pass-Through [14]

**MAIN > BASIC ENGINE > MECHANISM MENU**

- 1 Disc Motor...
- 2 Laser...
- 3 Tray...
- 4 Focus...
- 5 Radial...
- 6 Sledge...
- 7 Grooves...

**MAIN > BASIC ENGINE > SPECIAL DIAGNOSTICS MENU**

- 1 Read FlashID [70]
- 2 ROM Checksum [71]
- 3 Scratch Circuit [72]

**MAIN > PROCESSOR PERIPHERALS > PCM CLOCK MENU**

- 1 Ext PCM\_CLK In CDDA Mode (11.3MHz) [7a]
- 2 Ext PCM\_CLK In DVD Mode (12.3MHz) [7b]
- 3 Ext PCM\_CLK In DVD96kHz Mode (24.6MHz) [7c]

**MAIN > PROCESSOR PERIPHERALS > FLASH MENU**

- 1 Verify FLASH Checksum [6]
- 2 Show FLASH Checksum [62]

**MAIN > PROCESSOR PERIPHERALS > NVRAM MENU**

- 1 I2C NVRAM Acces [11]
- 2 NVRAM Config [34]
- 3 NVRAM Reset [35]

- 4 NVRAM Modify [36]
- 5 NVRAM Read/Wr Test [15]

**MAIN > MISCELLANEOUS > STATISTICS INFO MENU**

- 1 Total Nr Of Times Tray Open [47a]
- 2 Total Time Power On [47b]
- 3 Total Play-Time CDDA & VCD [47c]
- 4 Total Play-Time DVD [47d]

**Third Level Submenus**

**MAIN > AUDIO > EXT DAC BOARD > I2C TEST MENU**

- 1. I2C Test [66a]
- 2. I2C Enable Pin On [66b]
- 3. I2C Enable Pin Off [66c]

**MAIN > AUDIO > EXT DAC BOARD > CLOCK MENU**

- 1. Clock Internal [67a]
- 2. Clock External [67b]
- 3. Clock Upsampling 192k (963 only) [82a]
- 4. Clock Upsampling 96k (963 only) [82b]
- 5. Clock Upsampling On (963 only) [82c]
- 6. Clock Upsampling Off (963 only) [82d]

**MAIN > AUDIO > EXT DAC BOARD > AUDIO**

- 1. Audio Pre-Mute On [68a]
- 2. Audio Pre-Mute Off [68b]
- 3. Audio Center On [69a]
- 4. Audio Center Off [69b]

**MAIN > AUDIO > EXT DAC BOARD > LOW POWER STANDBY**

- 1. Low Power Standby On [81a]
- 2. Low Power Standby Off [81b]

**MAIN > AUDIO > EXT DAC BOARD > DAC MODE MENU**

- 1. DAC CDDA Mode [80a]
- 2. DAC DVD48 Mode [80b]
- 3. DAC DVD96 Mode [80c]
- 4. DAC DSD Mode [80d]

**MAIN > BASIC ENGINE > MECHANISM > DISC MOTOR MENU**

- 1 Disc Motor On [39a]
- 2 Disc Motor Off [39b]

**MAIN > BASIC ENGINE > MECHANISM > LASER MENU**

- 1 CD Laser On [58a]
- 2 CD Laser Off [58b]
- 3 DVD Laser On [58c]
- 4 DVD Laser Off [58d]

**MAIN > BASIC ENGINE > MECHANISM > TRAY MENU**

- 1 Tray Open [43b]
- 2 Tray Close [43a]

**MAIN > BASIC ENGINE > MECHANISM > FOCUS MENU**

- 1 Focus On [38a] (load DVD first)
- 2 Focus Off [38b]

**MAIN > BASIC ENGINE > MECHANISM > RADIAL MENU**

- 1 Radial Control On [40a] (load DVD first)
- 2 Radial Control Off [40b]

**MAIN > BASIC ENGINE > MECHANISM > SLEDGE MENU**

- 1 Sledge Inwards [41a]
- 2 Sledge Outwards [41b]

**MAIN > BASIC ENGINE > MECHANISM > GROOVES (Uses DVD) MENU**

- 1 Jump To Inside Grooves [42a]
- 2 Jump To Middle Grooves [42b]

- 3 Jump To Outside Grooves [42c]

## 5.8 Nuclei Error Codes

In the following tables the error description of the error codes will be described.

### 5.8.1 Audio Nuclei

Error code	Error text
1800	Audio Deemp On OK
1820	Audio Deemp Off OK
1880	Audio Deemp Tri OK
1900	Audio mute On OK
1920	Audio mute Off OK
1940	Audio Front LR mute On OK
1960	Audio Front LR mute Off OK
2000	Audio Pinknosie On OK
2001	Audio Pinknoise On DAC fail
2020	Audio Pinknoise Off OK
2040	Audio Beep tone On OK
2041	Audio Beep tone On DAC fail
2100	Audio Sine On OK
2101	Audio Sine On DAC fail
2120	Audio Sine Burst OK
2121	Audio Sine Burst DAC fail
6600	DAC I2C OK
6601	DAC I2C Bus busy
6602	DAC I2C expander
6603	DAC I2C DAC 4362
6620	DAC I2C enable OK
6640	DAC I2C disable OK
6700	DAC Clk internal OK
6701	DAC Clk internal I2C bus busy
6702	DAC Clk internal I2C failed
6720	DAC Clk external OK
6721	DAC Clk external I2Cbus busy
6722	DAC Clk external I2C failed
6800	DAC Audio pre-mute On OK
6801	DAC Audio pre-mute On I2C bus busy
6802	DAC Audio pre-mute On I2C failed
6820	DAC Audio pre-mute Off OK
6821	DAC Audio pre-mute Off I2C bus busy
6822	DAC Audio pre-mute Off I2C failed
6900	DAC Center On OK
6901	DAC Center On I2C bus busy
6902	DAC Center On I2C failed
6920	DAC Center Off OK
6921	DAC Center Off I2C bus busy
6922	DAC Center Off I2C failed
7900	DAC Reset OK
7901	DAC Reset I2C bus busy
7902	DAC Reset I2C expander
8000	DAC Mode CDDA OK
8001	DAC Mode CDDA I2C bus busy
8002	DAC Mode CDDA I2C failed
8020	DAC Mode DVD48 OK
8021	DAC Mode DVD48 I2C bus busy
8022	DAC Mode DVD48 I2C failed
8040	DAC Mode DVD96 OK
8041	DAC Mode DVD96 I2C bus busy
8042	DAC Mode DVD96 I2C failed

Error code	Error text
8060	DAC Mode DSD OK
8061	DAC Mode DSD I2C bus busy
8062	DAC Mode DSD I2C failed
8100	DAC Low Power Standby On OK
8101	DAC Low Power Standby On I2C bus busy
8102	DAC Low Power Standby On I2C failed
8120	DAC Low Power Standby Off OK
8121	DAC Low Power Standby Off I2C bus busy
8122	DAC Low Power Standby Off I2C failed
8200	DAC Upsample 192k OK
8201	DAC Upsample 192k I2C bus busy
8202	DAC Upsample 192k I2C failed
8220	DAC Upsample 96k OK
8221	DAC Upsample 96k I2C bus busy
8222	DAC Upsample 96k I2C failed
8240	DAC UpSample On OK
8241	DAC UpSample On bus busy
8242	DAC UpSample On I2C failed
8260	DAC UpSample Off OK
8261	DAC UpSample Off bus busy
8262	DAC UpSample Off I2C failed

### 5.8.2 Basic Engine Nuclei

Error code	Error text
3900	Test successful
3901	"Parity error from Basic Engine to Serial"
3902	"Unexpected response from Basic Engine"
3903	"Communication time-out error"
3904	"Basic Engine returned error number 0xXX"
3921	"Parity error from Basic Engine to Serial"
3922	"Unexpected response from Basic Engine"
3923	"Communication time-out error"
3924	"Basic Engine returned error number 0xXX"
3800	Test successful
3801	"Parity error from Basic Engine to Serial"
3802	"Unexpected response from Basic Engine"
3803	"Communication time-out error"
3804	"Basic Engine returned error number 0xXX"
3805	"Focus loop could not be closed"
3820	Test successful
3821	"Parity error from Basic Engine to Serial"
3822	"Unexpected response from Basic Engine"
3823	"Communication time-out error"
3824	"Basic Engine returned error number 0xXX"
4200	Test successful
4201	"Parity error from Basic Engine to Serial"
4202	"Unexpected response from Basic Engine"
4203	"Communication time-out error"
4204	"Basic Engine returned error number 0xXX"
4205	"Sledge could not be moved to home position"
4206	"Focus loop could not be closed"
4207	"Motor not on speed within time-out"
4208	"Radial loop could not be closed"
4209	"PLL could not lock in accessing or tracking state"

Error code	Error text
4210	"Subcode or sector information could not be read"
4211	"Requested subcode item could not be found"
4212	"TOC could not be read in time"
4213	"Seek could not be performed"
4220	Test successful
4221	"Parity error from Basic Engine to Serial"
4222	"Unexpected response from Basic Engine"
4223	"Communication time-out error"
4224	"Basic Engine returned error number 0xXX"
4225	"Sledge could not be moved to home position"
4226	"Focus loop could not be closed"
4227	"Motor not on speed within time-out"
4228	"Radial loop could not be closed"
4229	"PLL could not lock in accessing or tracking state"
4230	"Subcode or sector information could not be read"
4231	"Requested subcode item could not be found"
4232	"TOC could not be read in time"
4233	"Seek could not be performed"
4240	Test successful
4241	"Parity error from Basic Engine to Serial"
4242	"Unexpected response from Basic Engine"
4243	"Communication time-out error"
4244	"Basic Engine returned error number 0xXX"
4245	"Sledge could not be moved to home position"
4246	"Focus loop could not be closed"
4247	"Motor not on speed within time-out"
4248	"Radial loop could not be closed"
4249	"PLL could not lock in accessing or tracking state"
4250	"Subcode or sector information could not be read"
4251	"Requested subcode item could not be found"
4252	"TOC could not be read in time"
4253	"Seek could not be performed"
4000	Test successful
4001	"Parity error from Basic Engine to Serial"
4002	"Unexpected response from Basic Engine"
4003	"Communication time-out error"
4004	"Basic Engine returned error number 0xXX"
4005	"Radial loop could not be closed"
4020	Test successful
4021	"Parity error from Basic Engine to Serial"
4022	"Unexpected response from Basic Engine"
4023	"Communication time-out error"
4024	"Basic Engine returned error number 0xXX"
4400	Test successful
4401	Test successful
4100	Test successful
4101	"Parity error from Basic Engine to Serial"
4102	"Unexpected response from Basic Engine"
4103	"Communication time-out error"

Error code	Error text
4104	"Basic Engine returned error number XX"
4120	Test successful
4121	"Parity error from Basic Engine to Serial"
4122	"Unexpected response from Basic Engine"
4123	"Communication time-out error"
4124	"Basic Engine returned error number XX"
4300	Test successful
4301	"Parity error from Basic Engine to Serial"
4302	"Unexpected response from Basic Engine"
4303	"Communication time-out error"
4304	"Basic Engine returned error number 0xXX"
4320	Test successful
4321	"Parity error from Basic Engine to Serial"
4322	"Unexpected response from Basic Engine"
4323	"Communication time-out error"
4324	"Basic Engine returned error number 0xXX"
3700	"Version: X.Y.Z"
3701	"Parity error from Basic Engine to Serial"
3702	"Unexpected response from Basic Engine"
3703	"Communication time-out error"
3704	"Basic Engine returned error number 0xXX"
5800	Test successful
5820	Test successful
5840	Test successful
5860	Test successful
5801	"Unexpected response from Basic Engine"
7000	"Manuf. ID: <XX>" "Device ID: <YY>"
7001	"Comm Test Failed"
7002	"Load Cmd Failed"
7003	"Load Dat Failed"
7004	"Run Cmd Failed"
7100	"ROM Checksum: XXXX"
7101	"Comm Test Failed"
7102	"Load Cmd Failed"
7103	"Load Dat Failed"
7104	"Run Cmd Failed"
7201	"Comm Test Failed"
7200	"Test successful"
7202	"Load Cmd Failed"
7203	"Load Dat Failed"
7204	"Run Cmd Failed"
7205	"Scratch circuit not OK"

### 5.8.3 Display PWB Nuclei

Error code	Error text
3000	"Test successful"
3001	"Disp not responding"
3002	"Disp key no response"
3003	"One or more patterns not correct"
3004	"Disp type invalid"
3020	"Test successful"
3021	"Disp not responding"
3022	"Disp key no response"
3023	"One or more patterns not correct"
3040	"Test successful"

Error code	Error text
3041	"Disp not responding"
3042	"Disp key no response"
3043	"One or more patterns not correct"
2700	"Model name in wich the test is running"
2701	"Disp key no response"
2702	"Disp not responding"
2707	"Stop key not pressed"
2708	"Pause key not pressed"
2709	"Play key not pressed"
2710	"Open/close key not pressed"
2713	"Previous key not pressed"
2714	"Next key not pressed"
2715	"More than one key not pressed"
2716	" Audio key not pressed"
2900	"Test successful"
2901	"Slave not responding"
2902	"Slave keyboard not responding"
2903	"Standby led not working"
2800	"Test successful"
2801	"Slave display controller not responding"
2802	"Slave keyboard not responding"
2803	"No key press received from remote control"
2600	"The ROM version of the slave processor = 0xXX, and the internal ID = 0xYY"
2601	"I2c bus busy"
2602	"I2c bus not working"
6000	P50 test
6001	"No readback on P50"
6002	"Disp not responding "
6003	"P50 readback error"

### 5.8.4 Processor & Peripherals Nuclei

Error code	Error text
700	Test successful
720	Test successful
740	Test successful
600	"All checksums are correct"
601	"Following checksum is faulty: BootCode1 Checksum is 0xY2 and is not correct (must be 0xZ2)"
601	"This test is not available when stand-alone compiled"
6200	"Checksums = 0xA1, 0xB1, 0xC1, 0xD1"
6201	"This test is not available when stand-alone compiled"
1000	Test successful
1001	Test successful
1020	Test successful
1021	Test successful
1100	Test successful

Error code	Error text
1104	"NVRAM reply time-out"
1200	Test successful
1202	"Slave bus not working"
1203	"Slave controller not responding"
1204	"Slave response is not correct"
5900	Test successful
5901	"I2c bus busy"
5902	"I2c bus not working"
5904	"DTS chip response not correct"
1300	Test successful
1301	"Parity error from basic engine to serial"
1302	"Parity error from serial to basic engine"
1303	"No communication between serial and basic engine"
1304	"Communication time-out error"
1600	Test successful
1601	"The DVD SDRAM is faulty"

### 5.8.5 Log Nuclei

Error code	Error text
3100	"Show error log"
3101	"Error log is invalid"
3102	"Error log could not be read from NVRAM"
3103	"I2C bus busy before start"
3200	"Show error bit"
3201	"Error log is invalid"
3202	"I2C bus busy before start"
3203	"Error log could not be read from NVRAM"
3300	"Error log is cleared"
3301	"Error log could not be cleared"
3302	"I2C bus busy before start"

### 5.8.6 Miscellaneous Nuclei

Error code	Error text
3400	Test successful
3401	"The configuration data could not be read from NVRAM"
3402	"I2C bus busy before start"
3500	"NVRAM is cleared"
3501	"The NVRAM could not be reset."
3502	"I2C bus busy before start"
3600	"NVRAM contents updated."
	"NVRAM contents and configuration checksum updated."
3601	"NVRAM contents could not be updated."
3602	"I2C bus busy before start"
3603	"NVRAM contents could not be read"
3604	"NVRAM not accessible."
3605	"NVRAM checksum could not be updated."

Error code	Error text
1500	Test successful
1502	"NVRAM access time-out"
1504	"NVRAM fails"
5400	Test successful
5401	"I2c bus busy"
5402	"I2c bus not working"
5403	"Scart switch controller not responding"
5404	"Scart switch controller response not correct"
5500	Test successful
5501	"I2c bus busy"
5502	"I2c bus not working"
5520	Test successful
5521	"I2c bus busy"
5522	"I2c bus not working"
5523	"Scart switch controller not responding"
5200	Test successful
5201	"I2c bus busy"
5202	"I2c bus not working"
5300	Test successful
5301	"I2c bus busy"
5302	"I2c bus not working"
5320	Test successful
5321	"I2c bus busy"
5322	"I2c bus not working"
4700	"Number of times Tray went Open : XX"
4701	The total number of times tray went open could not be read from NVRAM.
4702	I2C bus busy before start
4720	"Total Power On time (minutes) : XX"
4721	The total power-on time could not be read from NVRAM.
4722	I2C bus busy before start
4740	"Total CDDA & VCD disks Play-time (minutes) : XX"
4741	The playtime of CDDA & VCD disks could not be read from NVRAM.
4742	I2C bus busy before start
4760	"Total DVD disks Play-time (minutes) : XX"
4761	The playtime of DVD disks could not be read from NVRAM.
4762	I2C bus busy before start
4600	"Version of Application Software : XX"
4601	"The application version could not be read from NVRAM."
4602	"I2C bus busy before start"

### 5.8.7 Video Nuclei

Error code	Error text
1700	Video digital port OK
1701	Video digital port failed
1720	Pscan IO exp OK
1721	Pscan IO exp com failed
2300	Video colourbar On OK

Error code	Error text
2301	Color Denc On transmit error
2302	I2C Color Denc On bus busy
2320	Video colourbar Off OK
2340	Video colourbar On NTSC OK
2400	ADV7300 com OK
2401	I2C ADV7300 com bus busy
2402	ADV7300 com transit error
2403	No ack from ADV7300 com
2404	ADV7300 com response error
2420	FLI2200 com OK
2421	I2C FLI2200 com bus busy
2422	FLI2200 com transmit error
2423	No ack from FLI2200 com
2424	FLI2200 com response error
2460	Proscan com OK
2440	ADV7190 com OK
2441	I2C ADV7190 com bus busy
2442	ADV7190 com transmit error
2443	No ack from ADV7190 com
2444	ADV7190 com response response
2500	Video scart Low OK
2501	I2C Scart Low bus busy
2502	Scart Low transmit error
2520	Video scart Mid OK
2521	I2C Scart Mid bus busy
2522	Scart Mid transmit error
2540	Video scart High OK
2541	I2C Scart High bus busy
2542	Scart High transmit error
6100	Video colour RGB OK
6120	Video colour YUV OK

### 5.8.8 Furore Nuclei

Error code	Error text
6300	Furore Sdram WRR_L OK
6301	Furore Sdram WRR_L DB fail
6302	Furore Sdram WRR_L AB fail
6303	Furore Sdram WRR_L DVC fail
6320	Furore Sdram WRR_H OK
6321	Furore Sdram WRR_H DB fail
6322	Furore Sdram WRR_H AB fail
6323	Furore Sdram WRR_H DVC fail
6400	Furore Sdram WRR_F_L OK
6401	Furore Sdram WRR_F_L DB fail
6402	Furore Sdram WRR_F_L AB fail
6403	Furore Sdram WRR_F_L DVC fail
6420	Furore Sdram WRR_F_H OK
6421	Furore Sdram WRR_F_H DB fail
6422	Furore Sdram WRR_F_H AB fail
6423	Furore Sdram WRR_F_H DVC fail
6500	Furore ID OK
6501	Furore ID invalid
8300	Furore reset OK
8301	Furore reset ID NOK
8400	Furore High OK
8420	Furore Low OK

## 5.9 Test Instruction Front Display and Audio/Video Board

These test instruction is designed specifically for SACD 2002 single disc models which has the following outputs:

- 6 Channel Audio output
- Coaxial / Optical digital output
- CVBS
- Component output YUV
- SVHS
- Double SCART output
- Front Display

### 5.9.1 General

- All the waveforms measurement carried out in these test instruction will be base on the testpoint indicated in the A/V Board and Front Display schematic diagram in the Service manual.
- Impedance of the measuring-equipment should be > 1M $\Omega$
- Most of the tests can be done using either the Diagnostic software "Player script" which can be found in the chapter "Diagnostic Software description and troubleshooting" or the Menu interface using the Service PC with a terminal emulation program ( e.g. Window Hyperterminal ) where it is possible to control the execution of the Diagnostic Nuclei
- Setup for the measurement will be done in set level with all modules connected as shown in the Wiring Block diagram.

### 5.9.2 General Start-Up Measurement

#### Supply Check:

Before starting the measurement,ensure that all power supply are connected to the A/V and Front Display board via conn.1420 and 1108 respectively.

Pin nr.	A/V Board	Front Display
Voltage	Conn. 1420	Conn. 1108
1	+3V3_Power	-
2	+3V3_Power	-
3	GND	-
4	+12V_Power	-
5	+12VSTBY	-
6	GND	+5VSTBY
7	+5VSTBY	+12V_Power
8	GND	-32V_Power
9	-12V_Power	-
10	GND	-
11	-32V_Power	-
12		-

#### Clock Check

Ensure the present of the clock to the DAC and the slave  $\mu$ P.

Clock Name	Testpoint	Frequency
PCM_CLK	I116	11.2896MHz $\pm$ 0.02% tolerance
XOUT	S1	8MHz $\pm$ 0.2% tolerance

#### Audio Mute Check

Measure the Audio mute voltage input at pin 22 of connector 1421

Status	Value
AudioMuteOn	HIGH (>3V)
AudioMuteOff	LOW (<3V)

To toggle between ON and OFF,use the following commands:

Ref.#	Command Name	Remarks
19a	AudioMuteOn	Audio Mute On
19b	AudioMuteOff	Audio Mute Off

### 5.9.3 Audio DAC And Amplifier

Ensure that the Audio mute signal is OFF

To check the DAC and buffer amplifier, send the following commands.

Ref.#	Command Name	Remarks	Audio output
21a	AudioSineOn	Audio Sine signal ON	Sine, 1KHz on stereo
----	Press stop button	Audio Sine signal OFF	No waveform
20a	AudioPinkNoiseOn	Audio Pinknoise ON	Pink Noise on 6 channels
20b	AudioPinkNoiseOff	Audio Pinknoise OFF	No waveform

The audio signal ( sine or pink noise ) will also be present on the digital output ( SPDIF ). This can be checked by connecting digital signal to an amplifier with digital input.

Check the I2S and audio signal at the following testpoints:

Name	Testpoint
PCM_LRCLK	I112
PCM_SCLK	I114
PCM_CLK	I116
SDT1	I110
SDT2	I106
SDT3	I102
DIG_OUT	I629
STEREO L/R OUT	I510 / I520
FRONT L/R OUT	I552 / I524
SURROUND L/R OUT	I533 / I536
CENTRE OUT	I530
SUB WOOFER L/R OUT	I527

All waveforms can be referred to the A/V board schematic diagram.

### 5.9.4 Video Output And Buffer Amplifier

Check DC output-level at all video cinch output : 1.0V DC  $\pm$  10%

Generate a color bar using the following software commands:

Ref.#	Command Name	Remarks
23a	VideoColDencOn	Colour DENC ON
23b	VideoColDencOff	Colourbar DENC OFF

Check the video outputs at the following testpoints:

Name	Testpoint
GREEN_SCART	I601
BLUE_SCART	I600
RED_SCART	I602
CVBS out_Mono	I662
C_Mono	I675
Y_Mono	I667

All waveforms can be referred to the A/V board schematic diagram.

### 5.9.5 Play and 16/9 Detection

Check DC voltage at S-VIDEO-CHROMA output (pin 4) with a 6k8 ohm load and SCART connector 1403 (pin 16) and change the SCART0 and SCART1 input using the following commands:

Ref.#	Command Name	Remarks
25a	VideoScartLo	Sends out 0V $\pm$ 0.5V
25b	VideoScartMi	Sends out 6V $\pm$ 10%

Ref.#	Command Name	Remarks
25c	VideoScartHi	Sends out 12V $\pm$ 10%

### 5.9.6 Kill Circuit

To check the functionality of the Kill circuitry, the audio outputs has to be present by the following command:

Ref.#	Command Name	Remarks	Audio output
21a	AudioSineOn	Audio Sinewave ON	1kHz tone

Check the audio outputs at the audio cinch of the A/V and SCART board: 1kHz tone.

Activate the Kill circuit by using the following command:

Ref.#	Command Name	Remarks
19a	AudioMuteOn	Audio Mute On

Check the audio outputs at the audio L/R cinch and SCART of the A/V and SCART board respectively: No waveform  
Switch off the kill circuit by using the following command:

Ref.#	Command Name	Remarks
19b	AudioMuteOff	Audio Mute Off

Check the audio outputs at the audio L/R cinch and SCART of the A/V and SCART board: 1kHz tone

### 5.9.7 Digital Silence

Digital silence is a signal from the audio DAC7301 (MFL, MFR) and DAC7300 (MSR/MC), when there is no input to the audio DAC, or when the player is in STOP/PAUSE mode, or during disc changing track.

To check the MFL signal, use the following command and check the voltage level at pin 41 of 7200:

Ref.#	Command Name	Remarks	KILL_LR signal
21a	AudioSineOn	Audio Sinewave ON	LOW (<0.3V)
---	Press STOP button	Audio Sine signal OFF	HIGH (>4.5V)

### 5.9.8 Front Display

To check the segment display of the FTD, the following command can be used. And for full detail description of the test, refer to the chapter of "Diagnostic Software Player Script" which can be found in chapter "Diagnostic Software Description and Troubleshooting"

Ref.#	Command Name	Remarks
30a	DispDisplay	Turn ON local display

### 5.9.9 IR Receiver

Check at pin 22 of 7401 and observe if this line switches from LOW (<0.3V) to HIGH (>4.5V) when pressing a key on a philips RC5 or RC6 remote control

### 5.9.10 P50 Interface

P50 (or Easylink) is a bi-directional serial interface for communication between video equipment. To check for the functionality of the P50 Interface, refer to the chapter of 'Diagnostic Software Player Script' for full detail description.





# 6. Block and Wiring Diagram.

## Block Diagram DVD963SA

GENERAL BLOCK DIAGRAM FOR DVD963SA

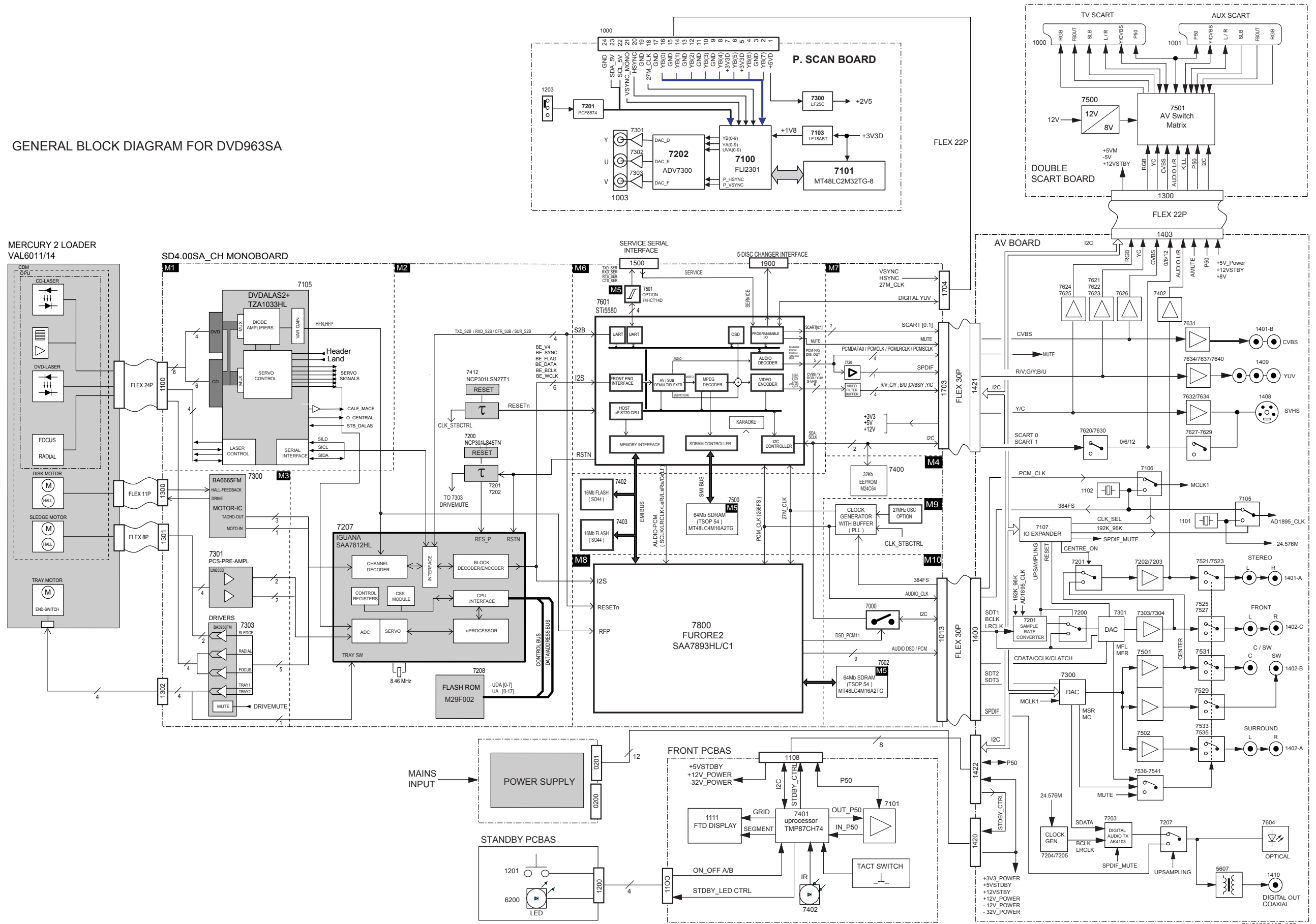

Wiring Diagram DVD963SA

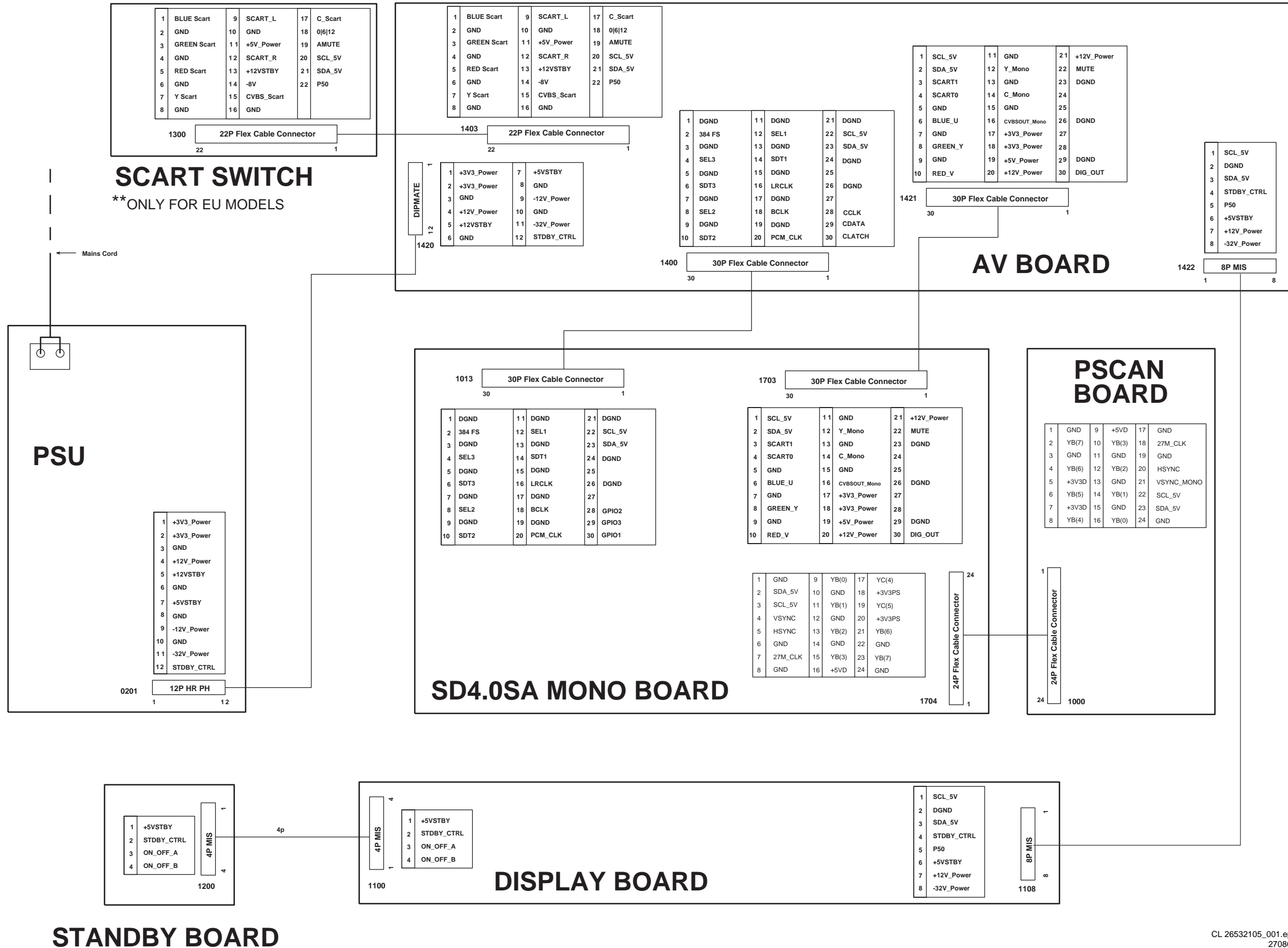

### Testpoint Overview A/V Board

I100	B11	I115	C8	I132	D11	I149	B11	I212	E10	I307	D2	I326	B7	I404	E9	I421	E6	I437	C7	I508	D4	I526	D5	I547	E4	I603	E16	I619	E15	I634	B3	I652	E15	I667	F14	I682	E18	I698	D8
I101	B11	I116	B10	I133	C10	I150	B9	I214	C10	I308	C3	I327	D7	I405	E16	I423	D6	I438	D5	I509	D4	I527	F5	I550	E5	I604	E15	I620	D14	I635	B2	I653	E15	I668	E15	I683	E18	I700	F10
I102	B10	I117	B9	I134	C10	I151	B9	I215	D8	I309	D3	I330	C8	I407	F7	I424	D7	I439	D6	I510	F9	I529	E5	I552	E7	I605	E15	I621	D13	I636	B2	I654	E15	I669	F15	I684	E19	I701	E14
I103	B11	I118	B9	I135	D11	I152	B9	I216	D8	I310	C5	I331	C7	I408	F8	I425	F6	I440	D7	I512	D3	I530	F5	I553	E7	I606	B16	I622	C14	I637	E16	I655	C15	I670	F14	I685	F19	I702	E11
I104	B10	I119	B9	I136	C10	I154	C11	I217	D8	I311	C5	I332	C7	I409	F8	I426	E6	I441	E7	I513	D4	I532	F4	I554	F3	I607	E15	I623	B15	I638	B13	I656	C16	I671	E11	I686	F17	I703	E12
I105	A10	I120	B11	I137	D11	I156	C11	I218	D8	I313	D5	I333	E6	I410	E16	I427	E7	I442	D6	I514	E2	I533	F4	I555	E4	I608	B17	I624	E16	I639	B13	I657	E10	I672	E11	I687	F19	I704	E13
I106	B10	I121	B11	I140	B8	I158	B13	I219	D10	I314	C5	I334	C7	I411	C6	I428	C5	I443	E6	I515	E2	I535	F3	I556	E5	I609	B18	I625	B15	I640	B2	I658	D2	I673	F11	I688	E18		
I107	B10	I122	B9	I141	B9	I159	C13	I220	E10	I317	E4	I335	E7	I412	D6	I429	C5	I444	D7	I516	E2	I536	F4	I557	F5	I610	B18	I626	E10	I641	B1	I659	E1	I674	E13	I689	E18		
I108	B10	I124	B17	I142	B9	I200	C8	I222	D9	I318	C5	I336	E7	I413	D5	I430	D5	I445	D6	I517	E2	I539	D4	I558	E6	I611	F17	I627	C19	I642	C2	I660	F10	I675	F15	I691	B2		
I109	D7	I126	B18	I143	C13	I201	C8	I223	D9	I320	D5	I339	B8	I414	E6	I431	D5	I501	D4	I518	F3	I541	E4	I569	E7	I613	C16	I628	C14	I643	C1	I661	F10	I676	F12	I692	C2		
I110	B10	I127	B18	I144	A13	I202	C8	I224	D9	I321	B7	I340	B8	I416	D5	I432	E5	I502	E3	I519	F2	I542	D4	I570	E9	I614	C15	I629	C13	I644	C2	I662	F10	I677	E12	I693	F14		
I111	B10	I128	B18	I145	C12	I203	C8	I225	D9	I322	C7	I341	B9	I417	D5	I433	D5	I504	C4	I520	F9	I543	E4	I571	E9	I615	E12	I630	B13	I645	D2	I663	F10	I678	E13	I694	E12		
I112	B10	I129	B18	I146	D12	I207	C8	I304	F1	I323	C6	I400	F9	I418	C7	I434	E5	I505	E1	I521	E8	I544	E5	I600	D16	I616	E12	I631	A13	I646	C18	I664	E15	I679	E13	I695	B15		
I113	B4	I130	D12	I147	C12	I208	D9	I305	F3	I324	B5	I401	E7	I419	D6	I435	C6	I506	D4	I522	F6	I545	E4	I601	E16	I617	E13	I632	B4	I650	C16	I665	E14	I680	E13	I696	F12		
I114	B10	I131	C11	I148	C13	I209	D10	I306	D2	I325	B5	I403	E8	I420	D6	I436	D6	I507	D5	I524	F6	I546	E4	I602	E16	I618	E14	I633	C12	I651	E15	I666	E14	I681	E13	I697	E7		

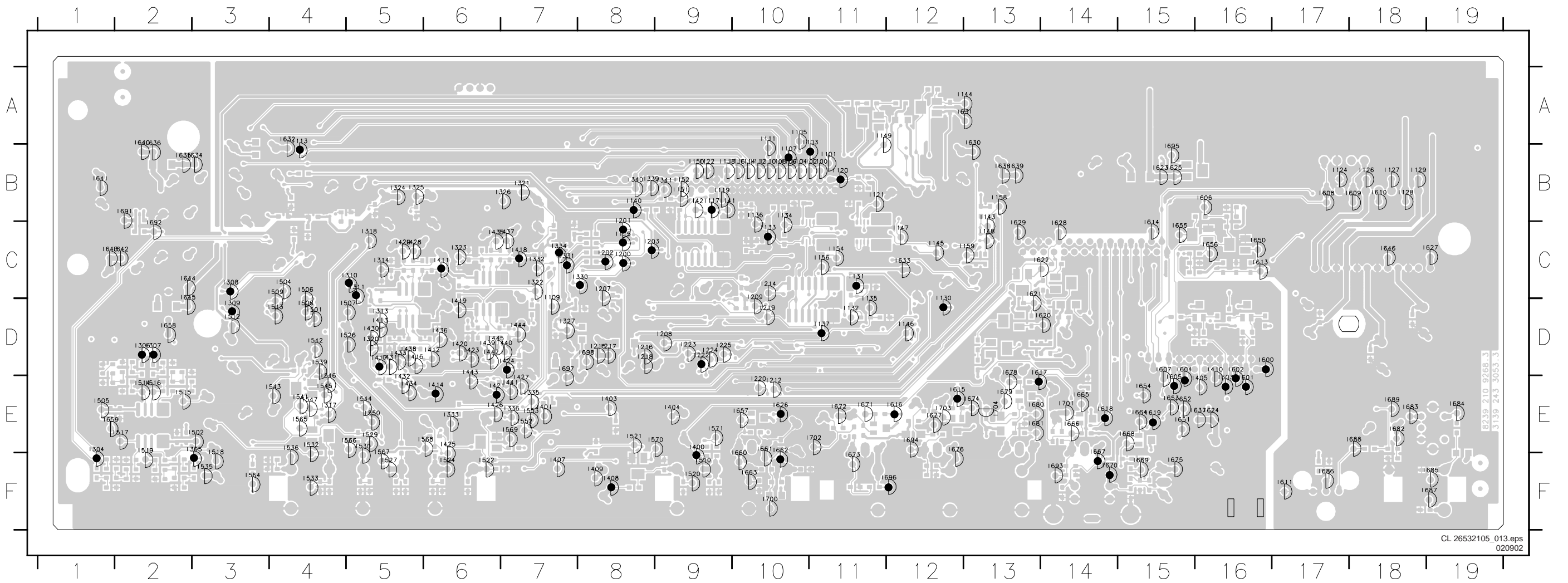

### Testpoint Overview Display Panel

I100 C22	I113 D7	I117 C8	I121 A10	I125 A7	I130 A13	I134 A12	I138 A12	I142 A16	I146 A16	I150 A18	I154 A18	I158 A17	I162 A17	I166 C21	I183 C6	I187 C12	I191 C21	I195 A6
I101 D22	I114 C17	I118 B10	I122 C13	I126 D1	I131 A13	I135 A13	I139 A11	I143 A16	I147 A13	I151 A17	I155 A17	I159 A7	I163 B17	I180 A14	I184 C6	I188 C12	I192 B21	I196 A6
I102 D22	I115 A11	I119 B11	I123 B11	I127 B4	I132 A12	I136 A12	I140 A13	I144 A16	I148 A13	I152 A17	I156 A18	I160 A7	I164 B18	I181 A15	I185 C3	I189 C12	I193 A22	
I108 A5	I116 B2	I120 A11	I124 C13	I129 A7	I133 A12	I137 A12	I141 A17	I145 A16	I149 A16	I153 A18	I157 A18	I161 A7	I165 C22	I182 A20	I186 B20	I190 B22	I194 C11	

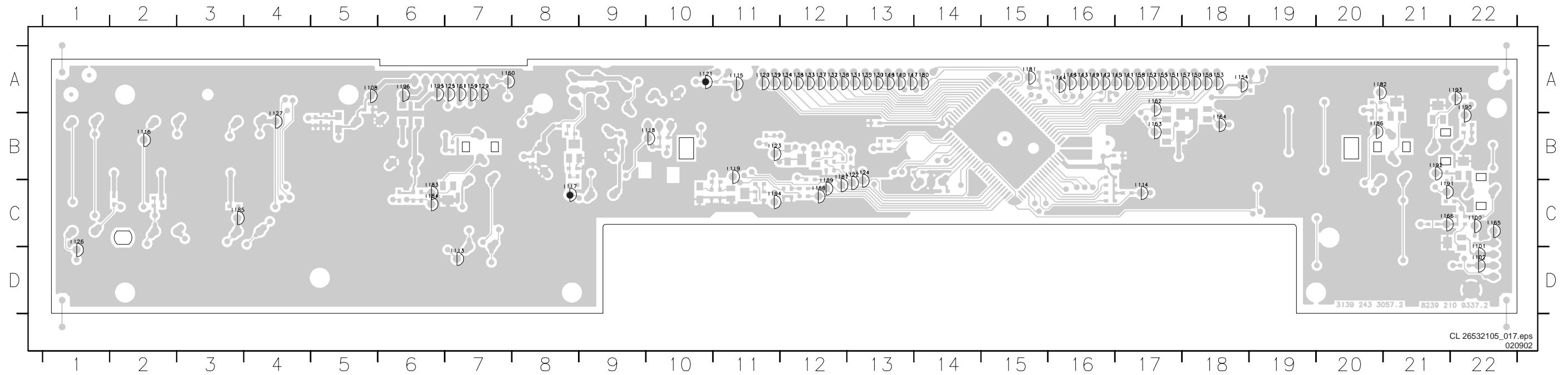

### Testpoint OverviewP-Scan Board

I100 F13	I103 G11	I106 D3	I201 F15	I208 D16	I211 E15	I214 D15	I217 E15	I220 B3	I223 E5	I300 B3	I303 D3	I306 E5	I309 G4	I312 D2	I315 F3	I318 E3	I321 D3
I101 E13	I104 F14	I107 C4	I203 F15	I209 G4	I212 D15	I215 D15	I218 F14	I221 D3	I224 D15	I301 C2	I304 G4	I307 G4	I310 C2	I313 D2	I316 F2	I319 D6	I322 E3
I102 E12	I105 G14	I108 E3	I207 E15	I210 E15	I213 D15	I216 D14	I219 E15	I222 C3	I225 E16	I302 F4	I305 C3	I308 F2	I311 E3	I314 D3	I317 F2	I320 C3	I323 G13

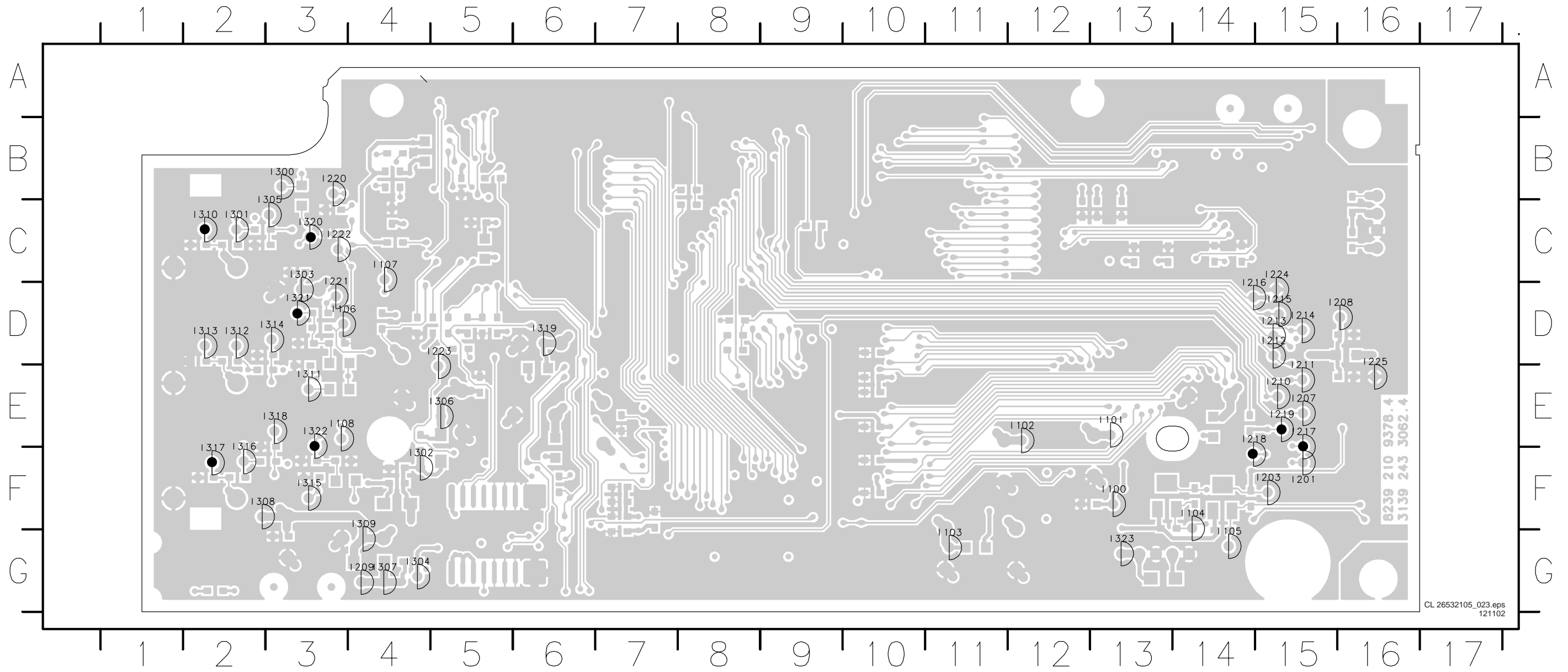



AV-Board: Clock & Control

**A1** SYS CLK & CONTROL

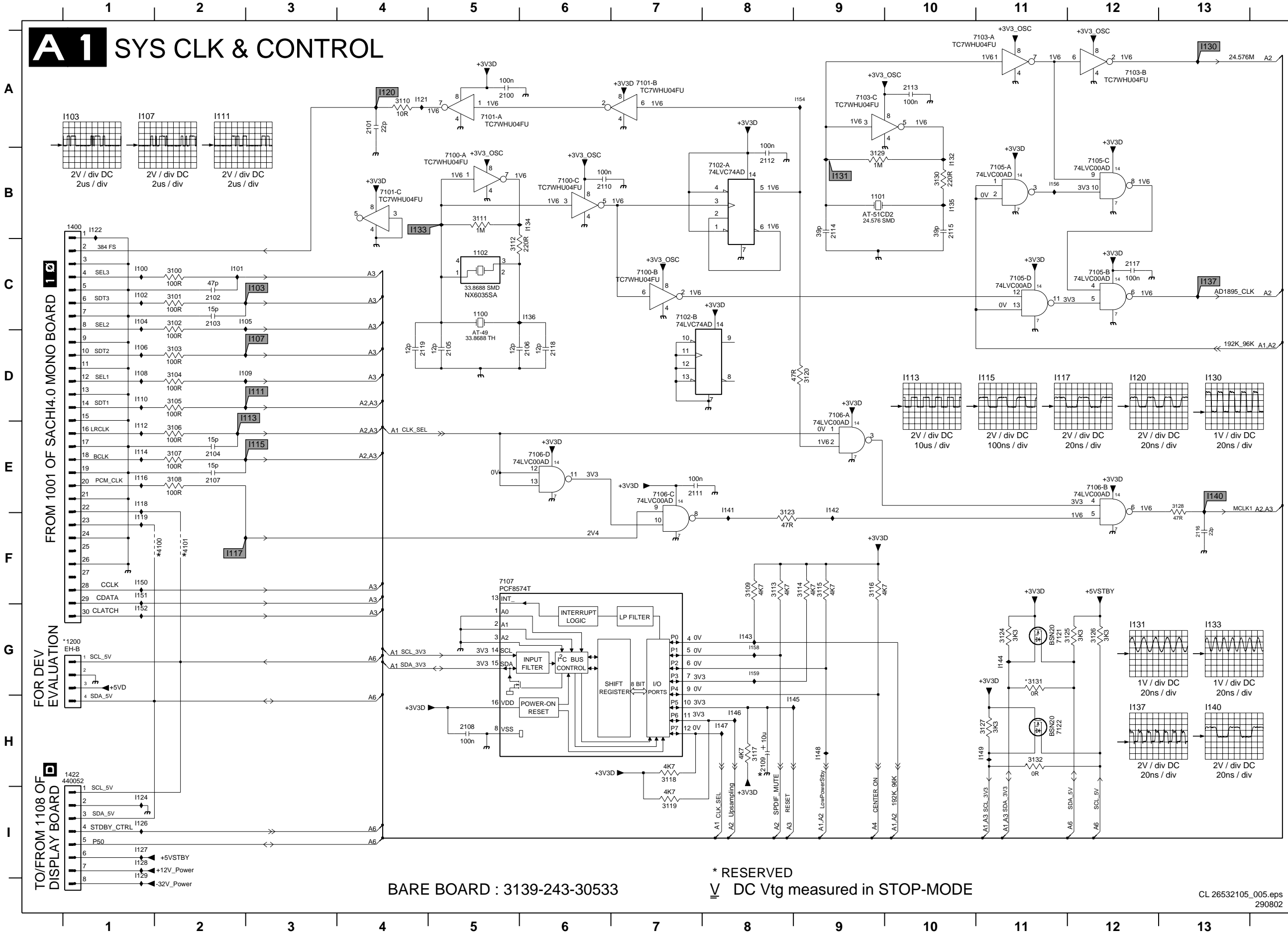

- 1100 C5
- 1101 B9
- 1102 C5
- 1200 G1
- 1400 B1
- 1422 H1
- 2100 A5
- 2101 A4
- 2102 C2
- 2103 C2
- 2104 E2
- 2105 D5
- 2106 D6
- 2107 E2
- 2108 H5
- 2109 H8
- 2110 B6
- 2111 E7
- 2112 B8
- 2113 A10
- 2114 B9
- 2115 B10
- 2116 F13
- 2117 C12
- 2118 D6
- 2119 D4
- 3100 C2
- 3101 C2
- 3102 C2
- 3103 D2
- 3104 D2
- 3105 D2
- 3106 E2
- 3107 E2
- 3108 E2
- 3109 F8
- 3110 A4
- 3111 B5
- 3112 C5
- 3113 F8
- 3114 F9
- 3115 F9
- 3116 F9
- 3117 H8
- 3118 H7
- 3119 I7
- 3120 D9
- 3123 F8
- 3124 G11
- 3125 G12
- 3126 G12
- 3127 H11
- 3128 E13
- 3129 B9
- 3130 B10
- 3131 G11
- 3132 H11
- 4100 F2
- 4101 F2
- 7100-A B5
- 7100-B C7
- 7100-C B6
- 7101-A A5
- 7101-B A7
- 7101-C B4
- 7102-A B8
- 7102-B C7
- 7103-A A10
- 7103-B A12
- 7103-C A9
- 7105-A B11
- 7105-B C12
- 7105-C B12
- 7105-D C11
- 7106-A D9
- 7106-B E12
- 7106-C E7
- 7106-D E6
- 7107 F5
- 7121 G11
- 7122 H11
- 1100 C1
- 1101 C2
- 1102 C1
- 1103 C2
- 1104 C1
- 1105 C2
- 1106 D1
- 1107 D2
- 1108 D1
- 1109 D2
- 1110 D1
- 1111 D2
- 1112 E1
- 1113 E2
- 1114 E1
- 1115 E2
- 1116 E1
- 1117 F2
- 1118 E1
- 1119 F1
- 1120 A4
- 1121 A4
- 1122 B1
- 1123 A1
- 1124 H1
- 1125 H1
- 1126 H1
- 1127 H1
- 1128 H1
- 1129 H1
- 1130 A13
- 1131 B9
- 1132 B10
- 1133 B5
- 1134 B6
- 1135 B10
- 1136 C6
- 1137 C13
- 1140 E13
- 1141 E8
- 1142 E9
- 1143 G8
- 1144 G11
- 1145 H8
- 1146 H8
- 1147 H8
- 1148 H9
- 1149 H11
- 1150 F1
- 1151 F1
- 1152 G1
- 1154 A9
- 1156 B11
- 1158 G8
- 1159 G8

BARE BOARD : 3139-243-30533

\* RESERVED  
 V DC Vtg measured in STOP-MODE

AV-Board: Upsampling

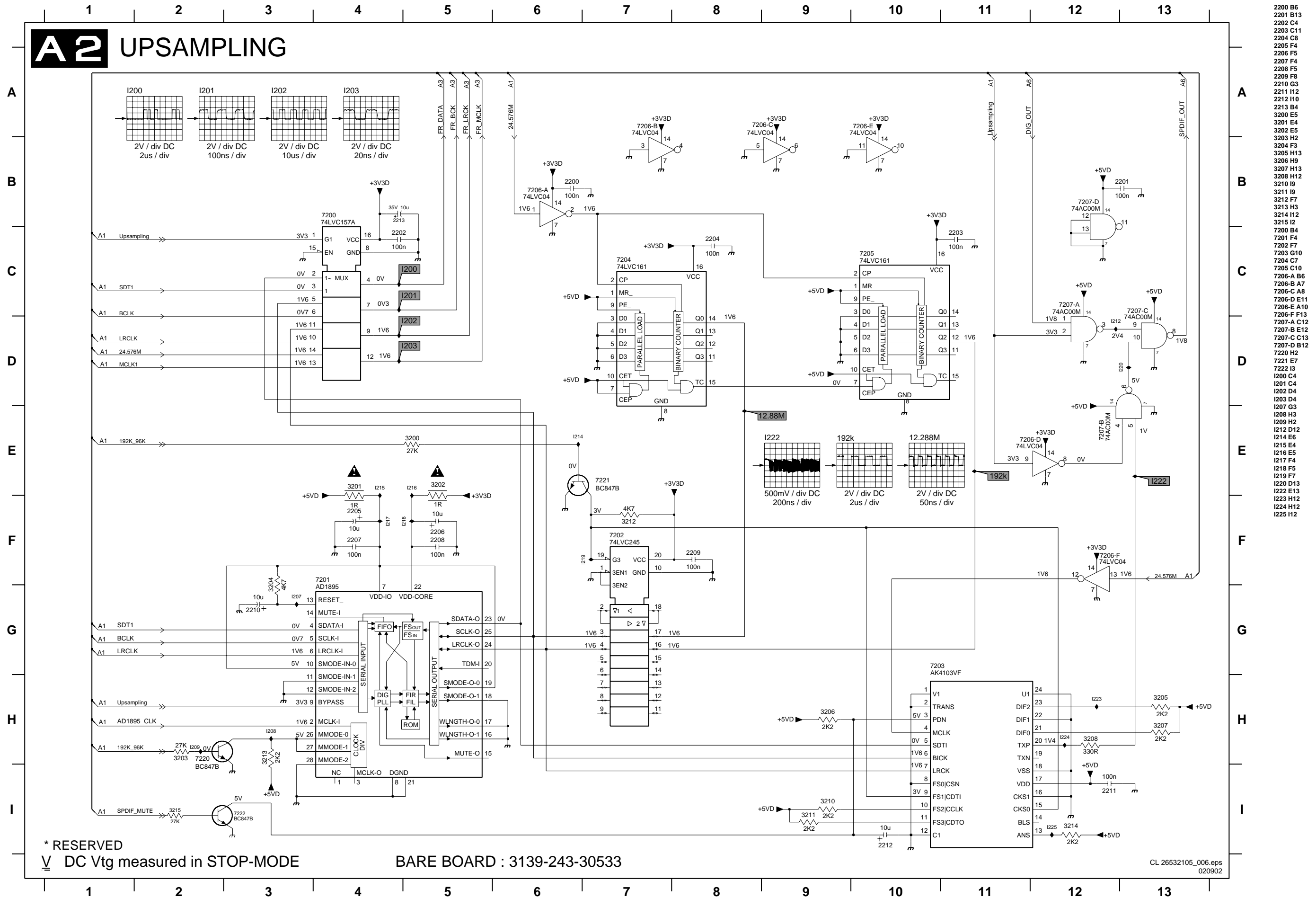

- 2200 B6
- 2201 B13
- 2202 C4
- 2203 C11
- 2204 C8
- 2205 F4
- 2206 F5
- 2207 F4
- 2208 F5
- 2209 F8
- 2210 G3
- 2211 I12
- 2212 I10
- 2213 B4
- 3200 E5
- 3201 E4
- 3202 E5
- 3203 H2
- 3204 F3
- 3205 H13
- 3206 H9
- 3207 H13
- 3208 H12
- 3210 I9
- 3211 I9
- 3212 F7
- 3213 H3
- 3214 I12
- 3215 I2
- 7200 B4
- 7201 F4
- 7202 F7
- 7203 G10
- 7204 C7
- 7205 C10
- 7206-A B6
- 7206-B A7
- 7206-C A8
- 7206-D E11
- 7206-E A10
- 7206-F F13
- 7207-A C12
- 7207-B E12
- 7207-C C13
- 7207-D B12
- 7220 H2
- 7221 E7
- 7222 I3
- I200 C4
- I201 C4
- I202 D4
- I203 D4
- I208 H3
- I209 H2
- I212 D12
- I214 E6
- I215 E4
- I216 E5
- I217 F4
- I218 F5
- I219 F7
- I220 D13
- I222 E13
- I223 H12
- I224 H12
- I225 I12

\* RESERVED  
 V DC Vtg measured in STOP-MODE

BARE BOARD : 3139-243-30533





AV-Board: Current to Voltage Converter

**A 4** Current to Voltage Converter

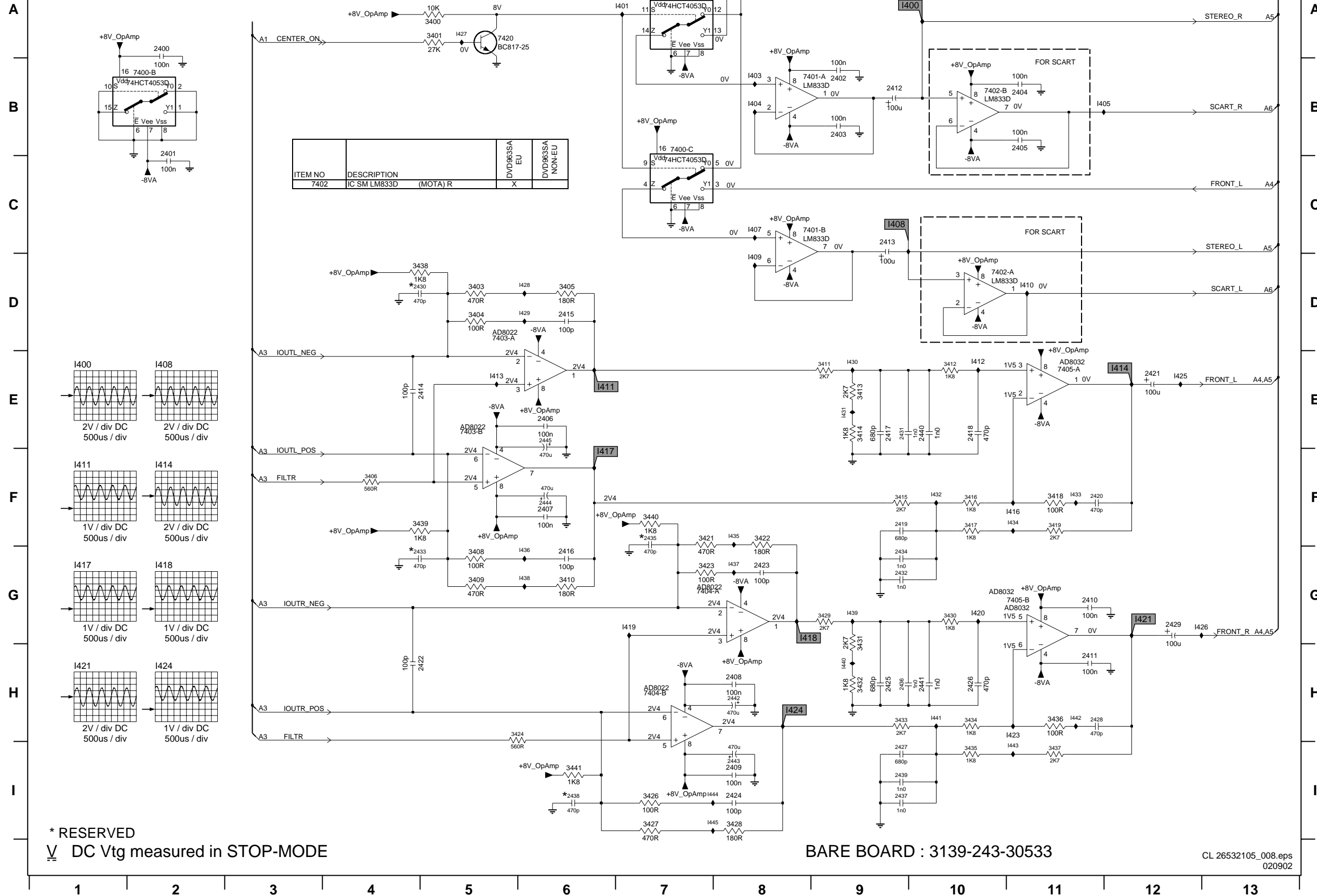

- 2400 A2
- 2401 C2
- 2402 B9
- 2403 B9
- 2404 B11
- 2405 B11
- 2406 E6
- 2407 F6
- 2408 H8
- 2409 I8
- 2410 G11
- 2411 H11
- 2412 B9
- 2413 C9
- 2414 E4
- 2415 D6
- 2416 G6
- 2417 E9
- 2418 E10
- 2419 F9
- 2420 F11
- 2421 E12
- 2422 H4
- 2423 G8
- 2424 I8
- 2425 H9
- 2426 H10
- 2427 I9
- 2428 H11
- 2429 G12
- 2430 D4
- 2431 E9
- 2432 G9
- 2433 G4
- 2434 G9
- 2435 F7
- 2436 H9
- 2437 I9
- 2438 I6
- 2439 I9
- 2440 E10
- 2441 H10
- 2442 H8
- 2443 I8
- 2444 F6
- 2445 F6
- 3400 A5
- 3401 A5
- 3403 D5
- 3404 D5
- 3405 D6
- 3406 F4
- 3408 G5
- 3409 G5
- 3410 G6
- 3411 E9
- 3412 E10
- 3413 E9
- 3414 E9
- 3415 F9
- 3416 F10
- 3417 F10
- 3418 F11
- 3421 F7
- 3422 F8
- 3423 G7
- 3424 H5
- 3426 I7
- 3427 I7
- 3428 I8
- 3429 G9
- 3430 G10
- 3431 G9
- 3432 H9
- 3433 H9
- 3434 H10
- 3435 I10
- 3436 H11
- 3437 I11
- 3438 D5
- 3439 F5
- 3440 F7
- 3441 I6
- 7400-A A7
- 7400-B B2
- 7400-C B7
- 7401-A B8
- 7401-B C8
- 7402-A D10
- 7402-B B10
- 7403-A D5
- 7403-B E5
- 7404-A G7
- 7404-B H7
- 7405-A E11
- 7405-B G11
- 7420 A5
- I400 A10
- I401 A7
- I403 B8
- I404 B8
- I405 B11
- I407 C8
- I408 C9
- I409 D8
- I410 D11
- I411 E6
- I412 E10
- I413 E5
- I414 E12
- I416 F11
- I417 F6
- I418 G8
- I419 G7
- I420 G10
- I421 G12
- I423 H11
- I424 H8
- I425 E12
- I426 G12
- I427 A5
- I428 D6
- I429 D6
- I430 E9
- I431 E9
- I432 F10
- I433 F11
- I434 F11
- I435 F8
- I436 G6
- I437 G8
- I438 G6
- I439 G9
- I440 H9
- I441 H10
- I442 H11
- I443 I7
- I444 I7
- I445 I7

AV-Board: Audio

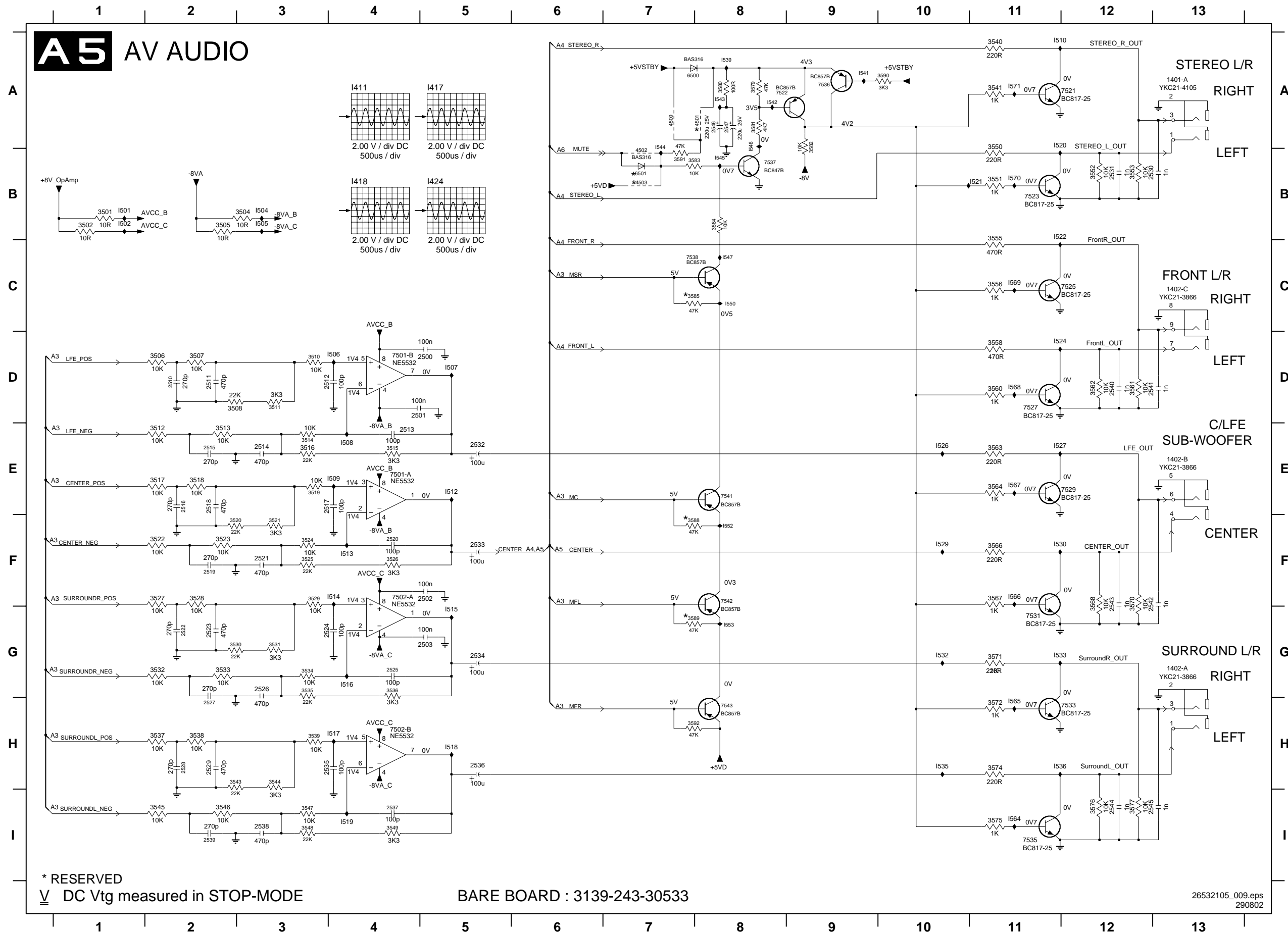

1401-A A13	3581 A8
1402-A G13	3582 A9
1402-B E13	3583 B7
1402-C C13	3584 B8
2500 D5	3585 C7
2501 D4	3588 F7
2502 F5	3589 G7
2503 G5	3590 A10
2510 D2	3591 B7
2511 D2	3592 H7
2512 D4	4500 A7
2513 E4	4501 A8
2514 E3	4502 B7
2515 E2	4503 B7
2516 E2	6500 A7
2517 E4	6501 B7
2518 E2	7501-A E4
2519 F2	7501-B D4
2520 F4	7502-A F4
2521 F3	7502-B H4
2522 G2	7521 A12
2523 G2	7522 A8
2524 G4	7523 B11
2525 G4	7525 C12
2526 G3	7527 D11
2527 H2	7529 E12
2528 H2	7531 G11
2529 H2	7533 H12
2530 B13	7535 I11
2531 B12	7536 A9
2532 E5	7537 B8
2533 F5	7538 C7
2534 G5	7541 E8
2535 H4	7542 F8
2536 H5	7543 H8
2537 I4	I501 B1
2538 I3	I502 B1
2539 I2	I504 B3
2540 D12	I505 B3
2541 D13	I506 D4
2542 F13	I507 D5
2543 F12	I508 E4
2544 I12	I509 E4
2545 I13	I510 A11
2546 A8	I512 E5
2547 A8	I513 F4
3501 B1	I514 F4
3502 B1	I515 G5
3504 B3	I516 G4
3505 B2	I517 H4
3506 D2	I518 H5
3507 D2	I519 I4
3508 D2	I520 A11
3510 D3	I521 B11
3511 D3	I522 B11
3512 E2	I524 D11
3513 E2	I526 E10
3514 E3	I527 E11
3515 E4	I529 F10
3516 E3	I530 F11
3517 E2	I532 G10
3518 E2	I533 G11
3519 E3	I535 H10
3520 F2	I536 H11
3521 F3	I539 A8
3522 F2	I541 A9
3523 F2	I542 A8
3524 F3	I543 A8
3525 F4	I544 A7
3526 F3	I545 B8
3527 F2	I546 A8
3528 F2	I547 C8
3529 F3	I550 C8
3530 G2	I552 F8
3531 G3	I553 G8
3532 G2	I564 H11
3533 G2	I565 H11
3534 G3	I566 F11
3535 G3	I567 E11
3536 G4	I568 D11
3537 H2	I569 C11
3538 H2	I570 B11
3539 H3	I571 A11
3540 A11	
3541 A11	
3543 H2	
3544 H3	
3545 I2	
3546 I2	
3547 I3	
3548 I3	
3549 I4	
3550 B11	
3551 B11	
3552 B12	
3553 B12	
3555 C11	
3556 C11	
3558 D11	
3560 D11	
3561 D12	
3562 D12	
3563 E11	
3564 E11	
3566 F11	
3567 F11	
3568 F12	
3570 F12	
3571 G11	
3572 H11	
3574 H11	
3575 I11	
3576 I12	
3577 I12	
3579 A8	
3580 A8	



Layout AV-Board (Top Side)

1100	C10	2103	B9	2207	D11	2319	B16	2426	D14	2510	C15	2546	D16	2627	B18	3103	B10	3205	D11	3415	D15	3440	C14	3519	D17	3584	E16	3617	D5	3644	E6	4604	D18	7102	C9	7400	E13	7543	E14
1101	D9	2104	B10	2208	D11	2321	B14	2427	D13	2511	C16	2547	E17	2628	B17	3104	B10	3207	D11	3416	D15	3441	D14	3520	D17	3585	E16	3618	D5	3661	E4	4614	E7	7103	C9	7401	E12	7600	B6
1102	C10	2107	B10	2209	D10	2400	E13	2428	D14	2512	D16	2606	B8	2633	D2	3105	B10	3208	D11	3417	E15	3501	D16	3521	D17	3588	E15	3621	E5	3672	F5	5300	B14	7107	C8	7402	D6	7601	B18
1200	B3	2108	B8	2210	D12	2401	F13	2429	E14	2513	D16	2608	B7	2635	D2	3106	B10	3212	D9	3418	D15	3504	C16	3522	D17	3589	E14	3624	D4	3674	B4	5600	E10	7200	C12	7405	D14	7602	D19
1201	B12	2109	C8	2211	D11	2404	D6	2431	D15	2514	D16	2609	B8	2637	D3	3107	B10	3213	D11	3419	E15	3506	C15	3523	D17	3590	E16	3625	D4	3675	B4	5603	C9	7201	D12	7420	E13	7603	C18
1400	B10	2112	B9	2212	C10	2409	D14	2432	E15	2515	D15	2610	C8	2639	C4	3108	B10	3214	D11	3424	D14	3507	C16	3524	D17	3591	E15	3626	D4	3676	B4	5604	E8	7202	D10	7501	D16	7604	F3
1402	F15	2113	D9	2213	C11	2410	E14	2436	D14	2516	D17	2612	B18	2640	D3	3116	C8	3215	C9	3429	D14	3508	D15	3525	D17	3592	E14	3627	D4	4100	B11	5605	E7	7203	D11	7521	E11	7622	D4
1403	D4	2116	C11	2301	C16	2411	D14	2439	E13	2517	D17	2613	B19	2641	E10	3117	C8	3305	D13	3430	D14	3510	C16	3526	D17	3602	E5	3630	D5	4101	B11	5607	E1	7204	D8	7522	D16	7623	D4
1408	F6	2117	C10	2302	B17	2412	E11	2440	D15	2518	D17	2614	F5	2642	E7	3118	C8	3310	C16	3431	D14	3511	D16	3551	F12	3603	E5	3631	D5	4300	B16	5608	E6	7205	D9	7527	E14	7625	D5
1409	F8	2200	D8	2305	B17	2413	F12	2441	D14	2519	D17	2616	A6	2643	E9	3119	C8	3311	C16	3432	D13	3512	D15	3564	E15	3605	D4	3632	D5	4301	B16	5609	F5	7206	D8	7529	E15	7626	D5
1410	F2	2201	E11	2307	B15	2417	D15	2442	C14	2520	D17	2618	E2	2644	E8	3120	C9	3314	E13	3433	D13	3513	D16	3566	E15	3606	D4	3633	D5	4304	B11	5610	E9	7207	D10	7531	E15	7627	E5
1420	C2	2202	C11	2309	B15	2418	D15	2443	D13	2521	D17	2619	D18	2645	D7	3123	C11	3401	E13	3434	D14	3514	D16	3574	F17	3608	D6	3635	E5	4305	B11	6500	E15	7220	D10	7535	F17	7628	E5
1421	C6	2203	D9	2311	D13	2419	D15	2444	D14	2532	D16	2620	C18	2646	D6	3125	B8	3411	D15	3435	D14	3515	D16	3579	E16	3609	D5	3637	E5	4500	E16	6501	E15	7221	D9	7537	E16	7629	E5
1422	B2	2204	D8	2312	B14	2420	D15	2445	C15	2533	D17	2624	F4	3100	B9	3200	D10	3412	D15	3436	D14	3516	D16	3580	D16	3612	E5	3639	E10	4501	E16	6603	E6	7222	C9	7538	E16		
1424	A14	2205	D12	2314	D13	2421	D15	2500	D16	2534	E18	2625	D13	3101	B9	3202	D11	3413	D15	3437	D14	3517	C17	3581	E16	3614	D4	3640	E10	4502	E15	6604	F5	7300	B16	7541	E15		
2102	B9	2206	D12	2317	B13	2425	D14	2501	C16	2536	F17	2626	C18	3102	B10	3203	D10	3414	D15	3438	C15	3518	C17	3583	E15	3615	D4	3643	E5	4503	E15	6605	E9	7301	C13	7542	E13		

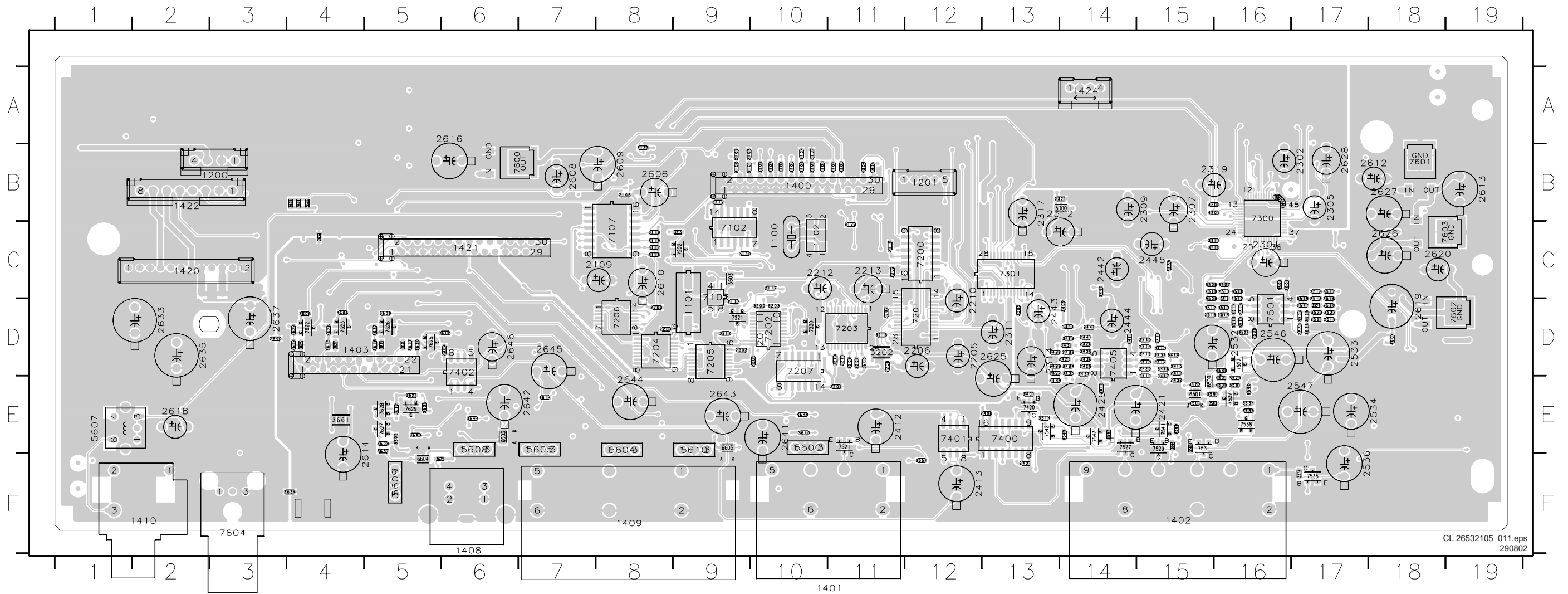

Layout AV-Board (Overview Bottom Side)

2100 B11	2306 B5	2407 D6	2502 E2	2538 F2	2611 F12	3111 C10	3204 D8	3405 C5	3527 D2	3541 E9	3560 E6	3601 C16	3638 C15	3656 E12	3677 D14	4602 E13	6601 E13	7525 E6	7640 E13
2101 B11	2308 B5	2408 C6	2503 E2	2539 F2	2615 E13	3112 B10	3206 C10	3406 D5	3528 D2	3543 F1	3561 F7	3604 D16	3641 F10	3657 E12	3678 D14	4606 B2	6602 F10	7533 E4	7641 B15
2105 C10	2310 D8	2414 D5	2522 D2	2540 F6	2617 F17	3113 B13	3210 D10	3408 D5	3529 E2	3544 F1	3562 F6	3607 D15	3642 F10	3659 B2	3679 D14	4607 C2	6606 D14	7536 E4	7642 D13
2106 B10	2313 C7	2415 C6	2523 E1	2541 F6	2621 F18	3114 C13	3211 D10	3409 D5	3530 D1	3545 F3	3563 E5	3610 C16	3645 E14	3660 E13	3680 D13	4608 F14	6607 F19	7620 C16	7643 C14
2110 B10	2315 C7	2416 D6	2524 E2	2542 F5	2622 F19	3115 C13	3300 B4	3410 D5	3531 D1	3546 F2	3567 E5	3611 C16	3646 E14	3662 E13	3681 D13	4609 F15	7100 C10	7621 D16	
2111 B9	2316 D7	2422 C6	2525 E2	2543 F5	2623 F18	3124 A12	3301 C8	3421 C6	3532 D2	3547 F2	3568 F5	3616 D16	3647 F14	3663 E13	3682 D13	4610 F11	7101 C11	7624 D16	
2114 C11	2318 B4	2423 C7	2526 D2	2544 F4	2630 F14	3126 A11	3304 D7	3422 C6	3533 D2	3548 F2	3570 F5	3619 B16	3648 F15	3664 B15	3683 C14	4611 E14	7105 D10	7630 C16	
2115 D11	2320 C4	2424 D7	2527 D2	2545 F4	2631 F15	3127 A12	3306 C8	3423 C6	3534 E2	3549 F2	3571 F4	3620 B16	3649 E11	3665 E19	3684 C14	4612 E11	7106 C9	7631 E10	
2118 B10	2322 C7	2430 C5	2528 F1	2600 B16	2632 F11	3128 B8	3307 C8	3426 D6	3535 E2	3550 F8	3572 E4	3622 D16	3650 E11	3666 D2	4102 E10	4613 E12	7121 A12	7632 E15	
2119 C10	2323 D7	2433 D5	2529 F2	2601 F10	2634 D18	3129 D11	3308 C8	3427 D6	3536 E2	3552 F9	3575 F3	3623 D16	3651 E11	3667 D7	4302 C4	5301 D8	7122 A11	7633 E14	
2120 C7	2402 E8	2434 E5	2530 F9	2602 F10	2636 D18	3130 D11	3313 E6	3428 D6	3537 F1	3553 F9	3576 F4	3628 D16	3652 D13	3669 E18	4303 B4	5601 A12	7403 D5	7634 E11	
2300 B4	2403 E8	2435 C6	2531 F9	2603 F15	2638 D17	3131 A12	3400 E7	3439 D5	3538 F1	3555 F6	3577 F4	3629 D15	3653 D13	3670 E18	4306 B9	5602 B3	7404 C6	7636 D13	
2303 C4	2405 E14	2437 E7	2535 F2	2604 F14	3109 B13	3132 A11	3403 C5	3502 E2	3539 F2	3556 E7	3582 D4	3634 C15	3654 E12	3671 B15	4600 E10	5606 F17	7502 E2	7637 E12	
2304 B4	2406 C5	2438 D6	2537 F2	2605 F15	3110 B11	3201 D8	3404 C5	3505 E1	3540 F9	3558 E6	3600 C16	3636 C15	3655 D14	3673 D16	4601 F12	6600 E12	7523 F8	7638 C13	

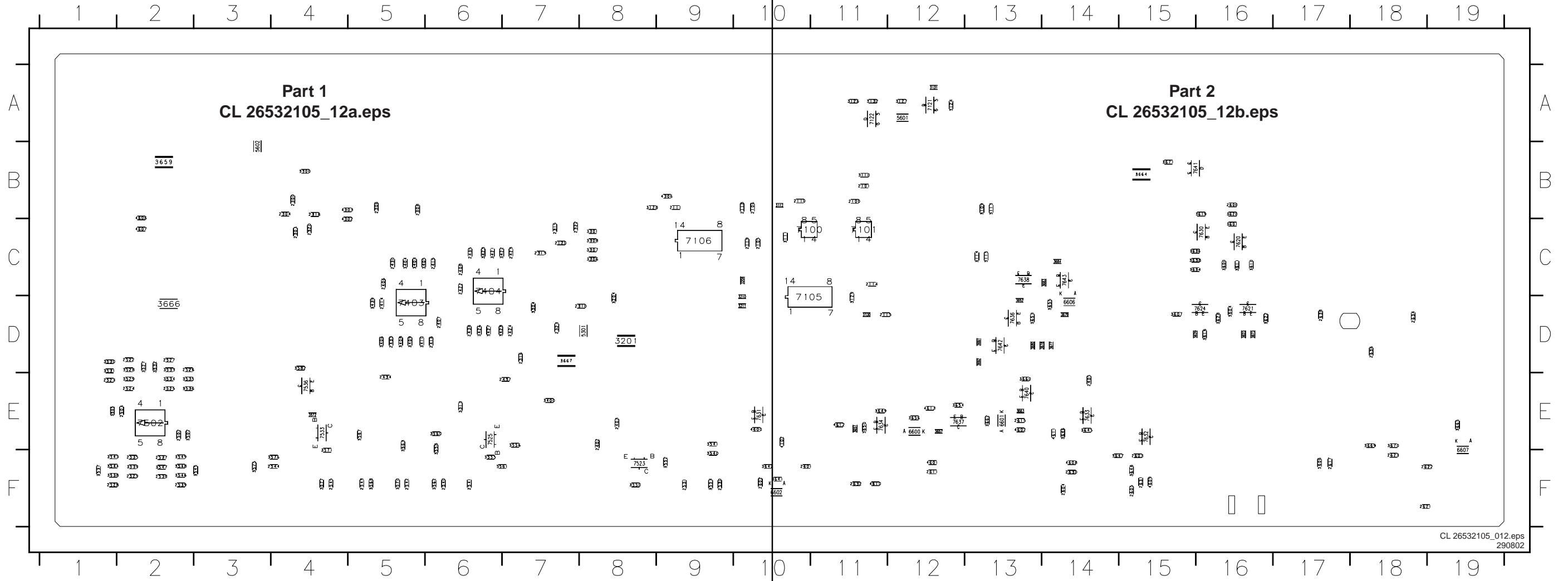

Layout AV-Board (Part 1 Bottom Side)

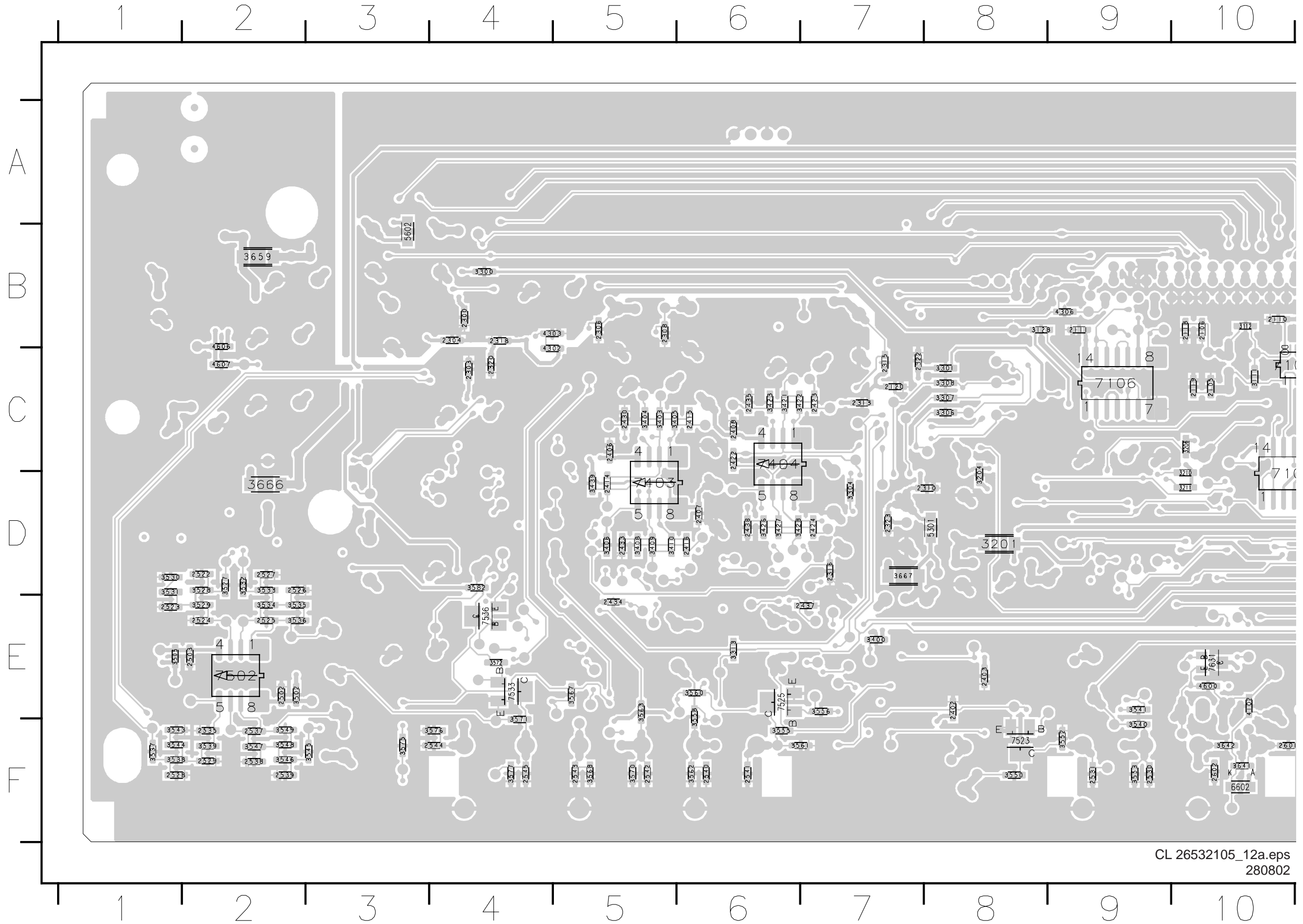

Layout AV-Board (Part 2 Bottom Side)

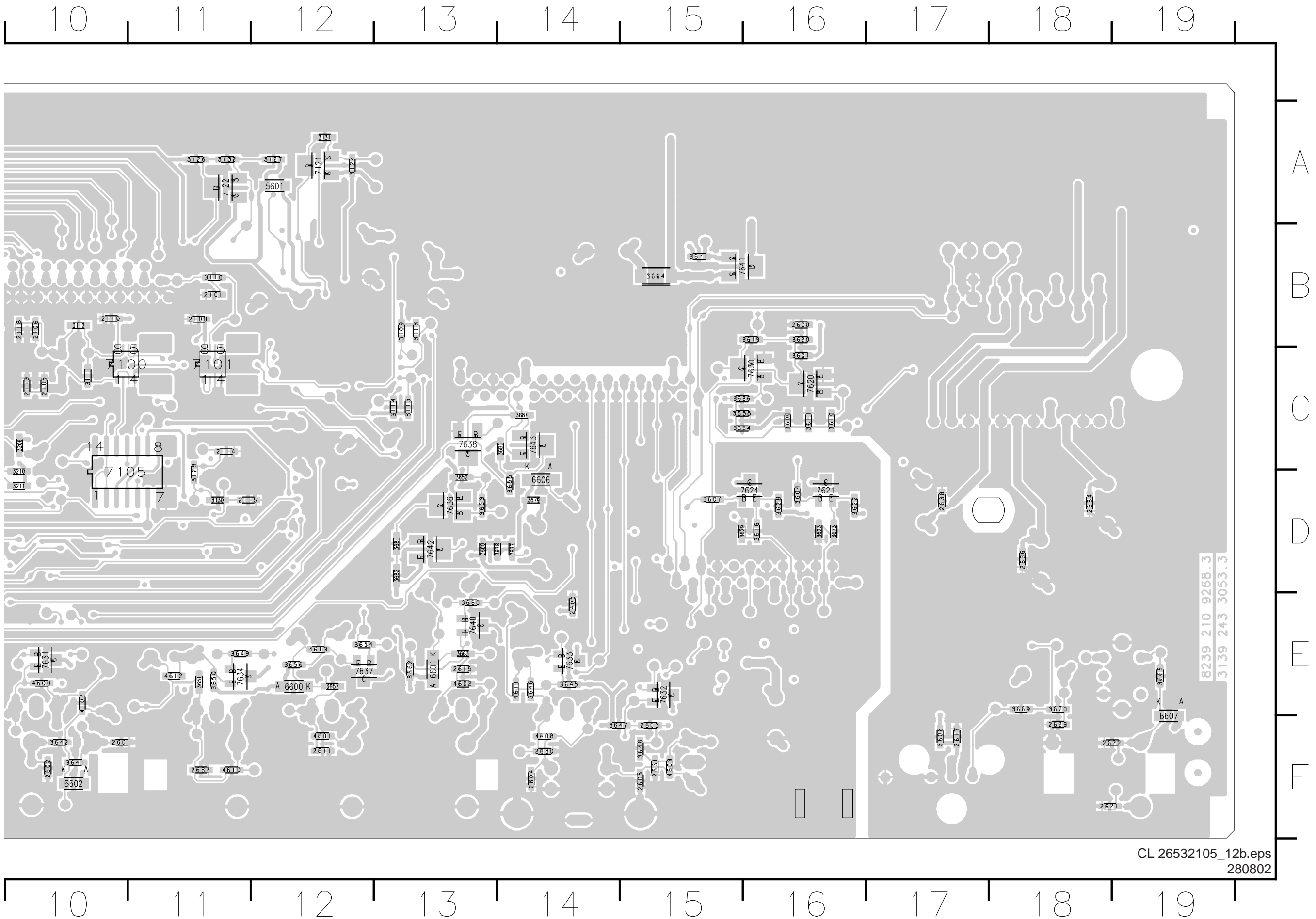

8239 210 9268.3  
3139 243 3053.3



Display Panel

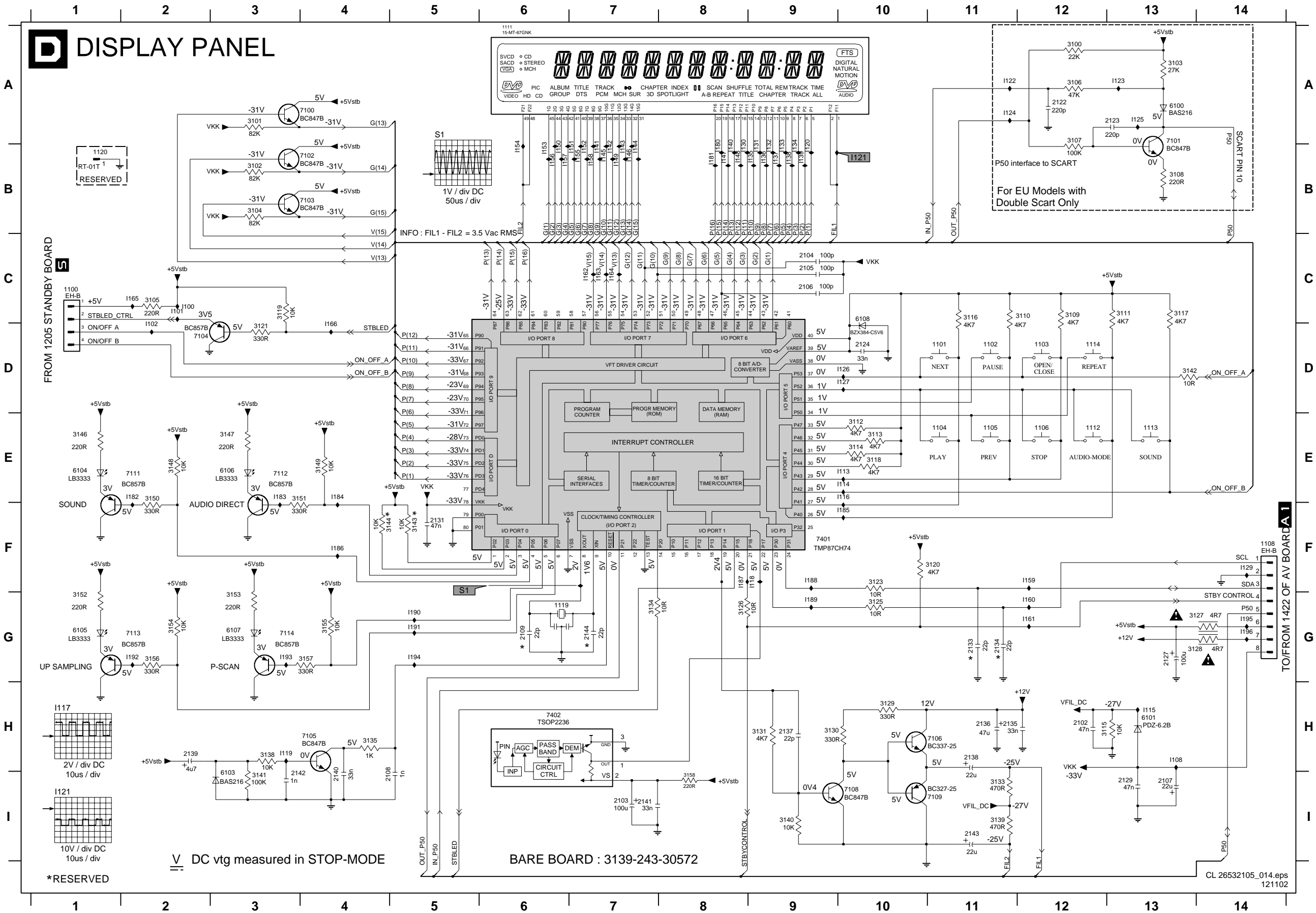

- 1100 C1
- 1101 D11
- 1102 D11
- 1103 D12
- 1104 E11
- 1105 E11
- 1106 E12
- 1108 F14
- 1111 A6
- 1112 E12
- 1113 E13
- 1114 D12
- 1119 G6
- 1120 B1
- 1120 H2
- 1123 I7
- 1124 A11
- 1125 C9
- 1126 C9
- 1127 H3
- 1128 I5
- 1129 F14
- 1129 G6
- 1129 H3
- 1130 B9
- 1131 B9
- 1132 B9
- 1133 B9
- 1134 G11
- 1135 H11
- 1136 H11
- 1137 H9
- 1138 H11
- 1139 H2
- 1140 I4
- 1141 I7
- 1142 H3
- 1143 H11
- 1144 G7
- 1144 I4
- 1145 B7
- 1146 B7
- 1147 B8
- 1148 B7
- 1149 B7
- 1150 B7
- 1151 B7
- 1152 B7
- 1153 B6
- 1154 B6
- 1155 B7
- 1156 B6
- 1157 B6
- 1158 B7
- 1159 F12
- 1160 G12
- 1161 G12
- 1162 C7
- 1163 C7
- 1164 C7
- 1165 C2
- 1166 D4
- 1167 I4
- 1168 F4
- 1169 F10
- 1170 G13
- 1171 F8
- 1172 F8
- 1173 H9
- 1174 G5
- 1175 F1
- 1176 B8
- 1177 D3
- 1178 F10
- 1179 G10
- 1180 G8
- 1181 G14
- 1182 G13
- 1183 F4
- 1184 F8
- 1185 F10
- 1186 F4
- 1187 F8
- 1188 F9
- 1189 G9
- 1190 G5
- 1191 G5
- 1192 G2
- 1193 G3
- 1194 G5
- 1195 G14
- 1196 G14
- 7402 H6
- 7402 C2
- 1108 H3
- 1108 H3
- 1110 H3
- 1110 H3
- 1111 H3
- 1111 H3
- 1112 H3
- 1112 H3
- 1113 H3
- 1113 H3
- 1114 H3
- 1114 H3
- 1115 H3
- 1115 H3
- 1116 H3
- 1116 H3
- 1117 H3
- 1117 H3
- 1118 H3
- 1118 H3
- 1119 H3
- 1119 H3
- 1120 H3
- 1120 H3
- 1121 H3
- 1121 H3
- 1122 H3
- 1122 H3
- 1123 H3
- 1123 H3
- 1124 H3
- 1124 H3
- 1125 H3
- 1125 H3
- 1126 H3
- 1126 H3
- 1127 H3
- 1127 H3
- 1128 H3
- 1128 H3
- 1129 H3
- 1129 H3
- 1130 H3
- 1130 H3
- 1131 H3
- 1131 H3
- 1132 H3
- 1132 H3
- 1133 H3
- 1133 H3
- 1134 H3
- 1134 H3
- 1135 H3
- 1135 H3
- 1136 H3
- 1136 H3
- 1137 H3
- 1137 H3
- 1138 H3
- 1138 H3
- 1139 H3
- 1139 H3
- 1140 H3
- 1140 H3
- 1141 H3
- 1141 H3
- 1142 H3
- 1142 H3
- 1143 H3
- 1143 H3
- 1144 H3
- 1144 H3
- 1145 H3
- 1145 H3
- 1146 H3
- 1146 H3
- 1147 H3
- 1147 H3
- 1148 H3
- 1148 H3
- 1149 H3
- 1149 H3
- 1150 H3
- 1150 H3
- 1151 H3
- 1151 H3
- 1152 H3
- 1152 H3
- 1153 H3
- 1153 H3
- 1154 H3
- 1154 H3
- 1155 H3
- 1155 H3
- 1156 H3
- 1156 H3
- 1157 H3
- 1157 H3
- 1158 H3
- 1158 H3
- 1159 H3
- 1159 H3
- 1160 H3
- 1160 H3
- 1161 H3
- 1161 H3
- 1162 H3
- 1162 H3
- 1163 H3
- 1163 H3
- 1164 H3
- 1164 H3
- 1165 H3
- 1165 H3
- 1166 H3
- 1166 H3
- 1167 H3
- 1167 H3
- 1168 H3
- 1168 H3
- 1169 H3
- 1169 H3
- 1170 H3
- 1170 H3
- 1171 H3
- 1171 H3
- 1172 H3
- 1172 H3
- 1173 H3
- 1173 H3
- 1174 H3
- 1174 H3
- 1175 H3
- 1175 H3
- 1176 H3
- 1176 H3
- 1177 H3
- 1177 H3
- 1178 H3
- 1178 H3
- 1179 H3
- 1179 H3
- 1180 H3
- 1180 H3
- 1181 H3
- 1181 H3
- 1182 H3
- 1182 H3
- 1183 H3
- 1183 H3
- 1184 H3
- 1184 H3
- 1185 H3
- 1185 H3
- 1186 H3
- 1186 H3
- 1187 H3
- 1187 H3
- 1188 H3
- 1188 H3
- 1189 H3
- 1189 H3
- 1190 H3
- 1190 H3
- 1191 H3
- 1191 H3
- 1192 H3
- 1192 H3
- 1193 H3
- 1193 H3
- 1194 H3
- 1194 H3
- 1195 H3
- 1195 H3
- 1196 H3
- 1196 H3
- 7401 F9

### Layout Display Panel (Top Side)

1100 D1	1102 A22	1104 A21	1106 A19	1111 B8	1113 B2	1119 B9	2103 B14	2127 B17	2138 A14	2143 A13	6105 C1	6107 B2	7109 A14
1101 C22	1103 C16	1105 C21	1108 A16	1112 B16	1114 C19	1120 D1	2107 A18	2136 B15	2139 C14	6104 B2	6106 B16	7106 A15	7402 B13

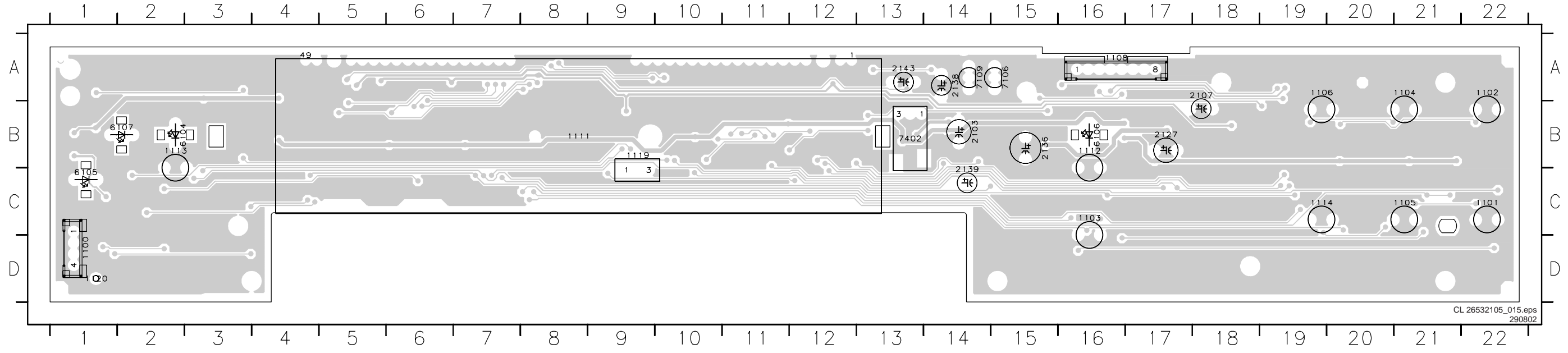

CL 26532105\_015.eps  
290802

### Layout Display Panel (Overview Bottom Side)

2102 B5	2109 B14	2131 B13	2140 C11	3101 A15	3106 B12	3111 C3	3116 C2	3121 C22	3128 B6	3134 C21	3141 C10	3147 B7	3152 C22	3157 A22	6108 B16	7104 C22	7113 B22
2104 A16	2122 B12	2133 C12	2141 B10	3102 A15	3107 B12	3112 B16	3117 C17	3123 C12	3129 B8	3135 C11	3142 D22	3148 A20	3153 B22	3158 B10	7100 B18	7105 C11	7114 A21
2105 A16	2123 B12	2134 C12	2142 C11	3103 B11	3108 B13	3113 C16	3118 C16	3125 C12	3130 B8	3138 C11	3143 B13	3149 C6	3154 C21	6100 B12	7101 B12	7108 B8	7401 B15
2106 A17	2124 B17	2135 B8	2144 C14	3104 A15	3109 C2	3114 C16	3119 C22	3126 B12	3131 C8	3139 A19	3144 B13	3150 A20	3155 B22	6101 B5	7102 B17	7111 A21	
2108 C11	2129 A5	2137 C8	3100 B11	3105 C22	3110 C2	3115 B5	3120 C6	3127 B6	3133 A11	3140 B8	3146 B20	3151 C6	3156 B21	6103 C10	7103 B17	7112 C7	

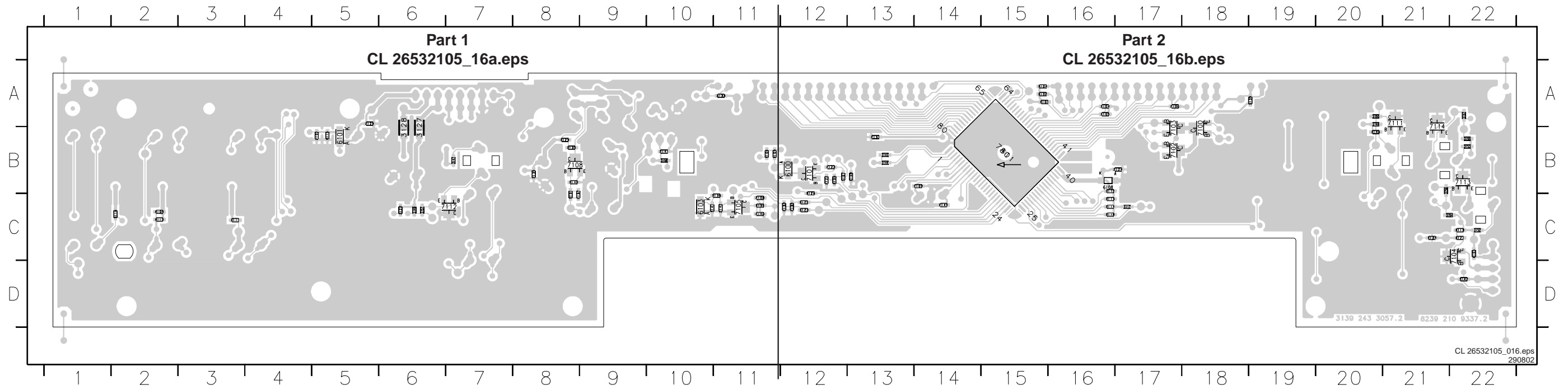

Layout Display Panel (Part 1 Bottom Side)

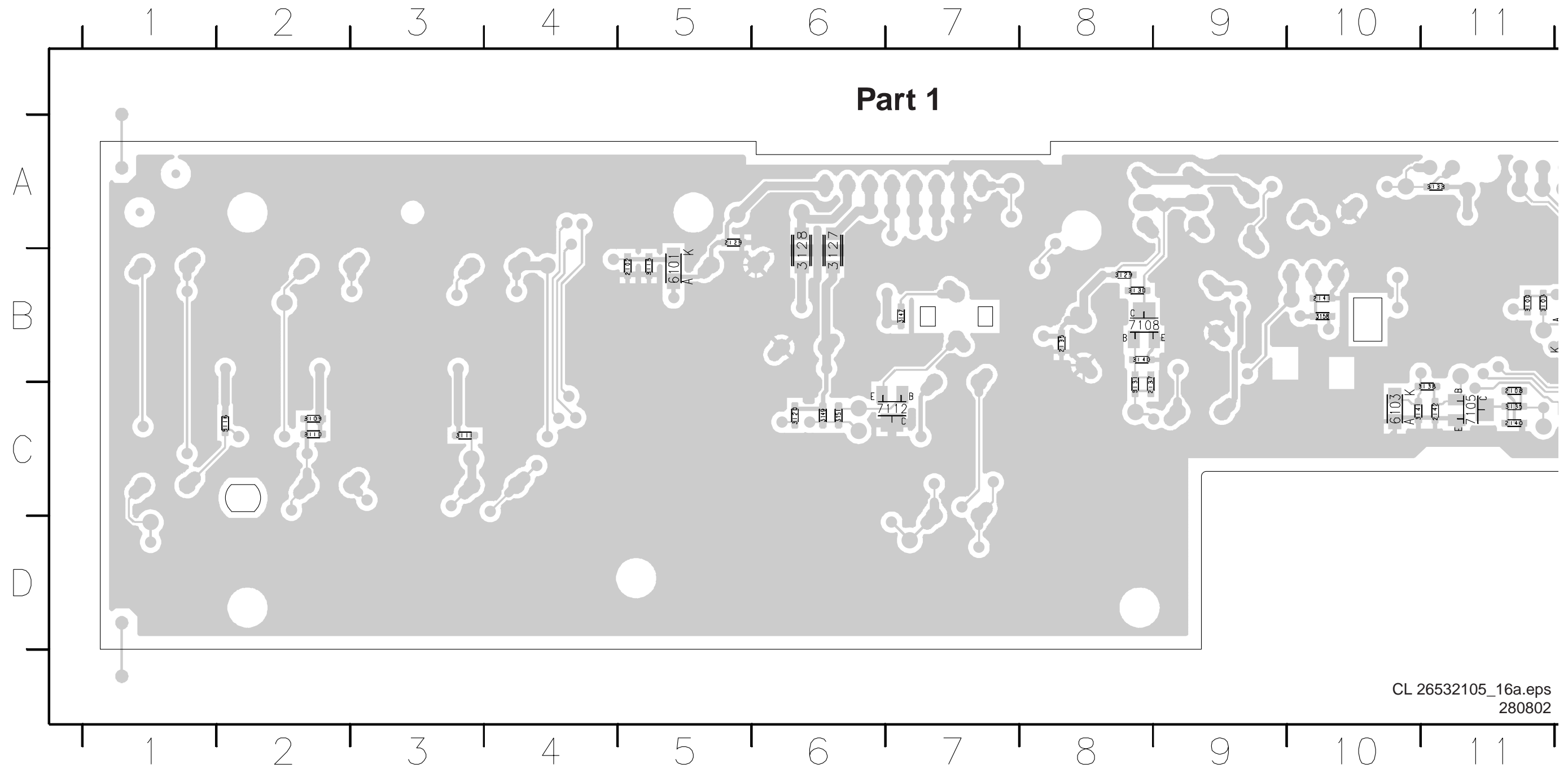

Layout Display Panel (Part 2 Bottom Side)

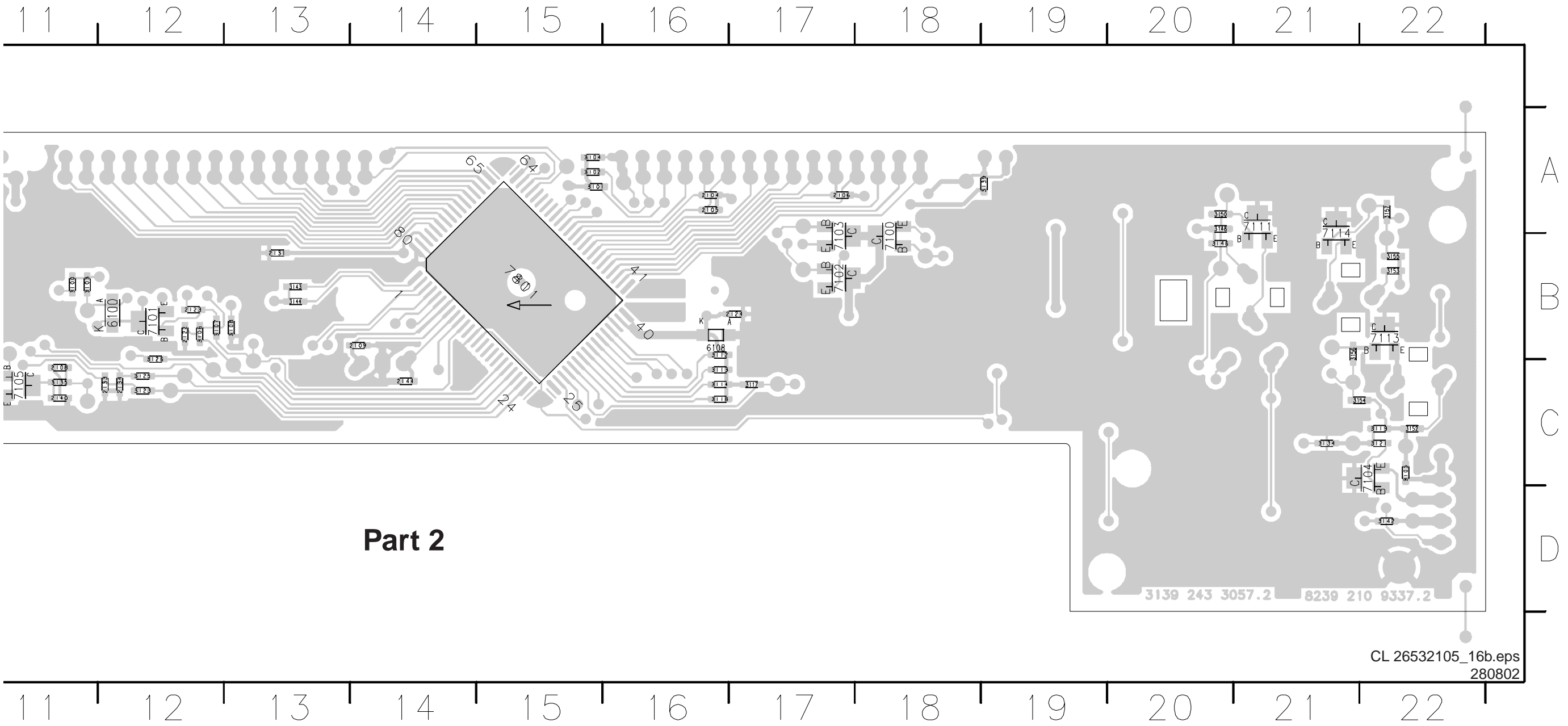

P-Scan Board: Line Doubler

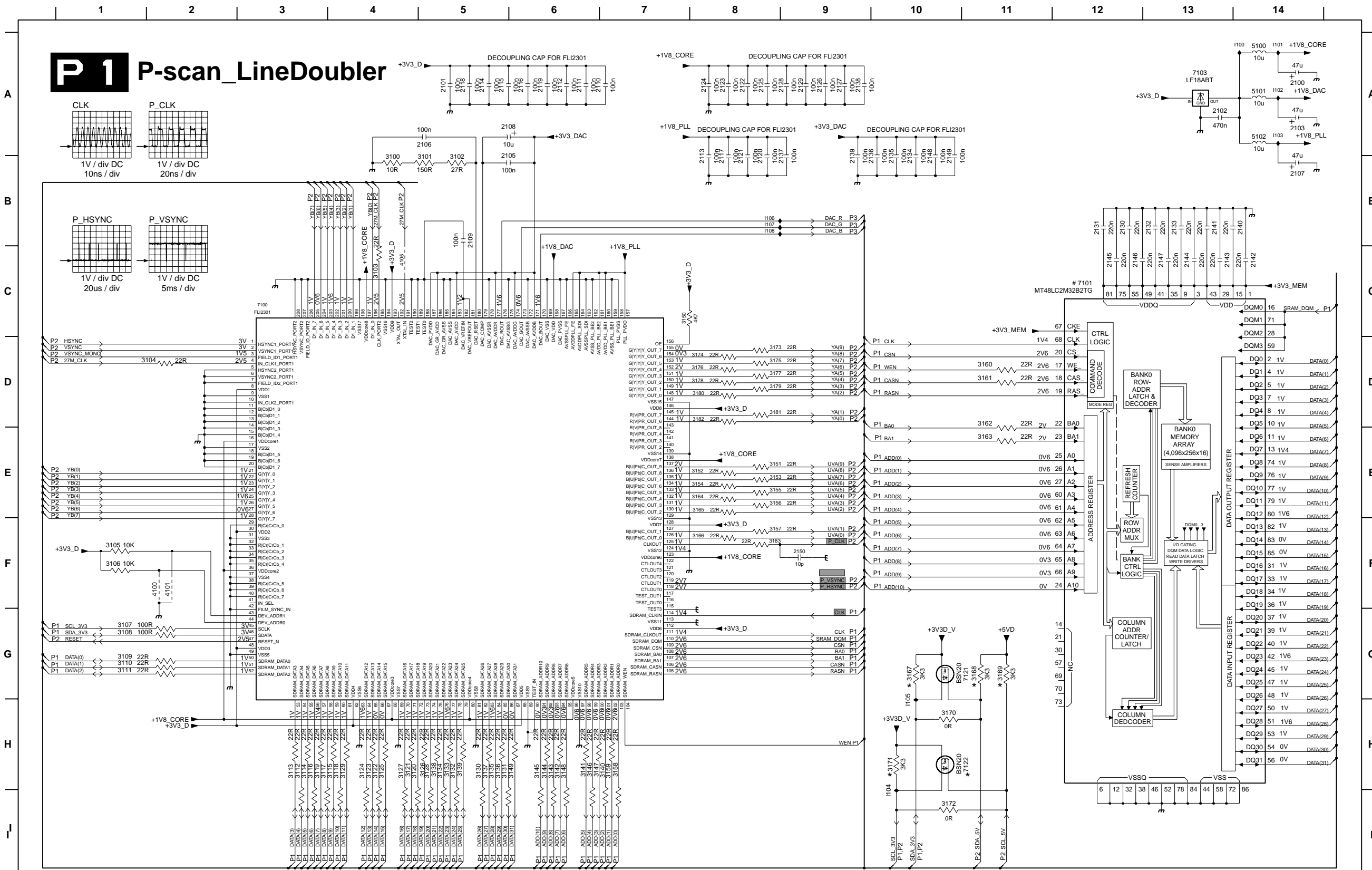

2100 A14	3168 G11
2101 A5	3169 G11
2102 A13	3170 H10
2103 A14	3171 H10
2105 B5	3172 H10
2106 A5	3173 D8
2107 B14	3174 D8
2108 A5	3175 D8
2109 B5	3176 D8
2110 A7	3177 D8
2111 A6	3178 D8
2112 A6	3179 D8
2113 B8	3180 D8
2114 A5	3181 D8
2115 A5	3182 D8
2116 A6	3183 F8
2117 B8	4100 F2
2118 A5	4101 F2
2119 A6	4105 C4
2120 B8	5100 A14
2121 B8	5101 A14
2122 A8	5102 A14
2123 A8	7100 C3
2124 A8	7101 C12
2125 A8	7103 A13
2126 A9	7121 G11
2127 A9	7122 H11
2128 A9	7123 H11
2129 A9	7124 H11
2130 B12	7125 H11
2131 B12	7126 H11
2132 C13	7127 H11
2133 B13	7128 H11
2134 B10	7129 H11
2135 B10	7130 H11
2136 B10	7131 H11
2137 B9	7132 H11
2138 A9	7133 H11
2139 B9	7134 H11
2140 B14	7135 H11
2141 B13	7136 H11
2142 C14	7137 H11
2143 C13	7138 H11
2144 C13	7139 H11
2145 C12	7140 H11
2146 C12	7141 H11
2147 C13	7142 H11
2148 B10	7143 H11
2149 B10	7144 H11
2150 F9	7145 H11
3100 B4	7146 H11
3101 B5	7147 H11
3102 B5	7148 H11
3103 C4	7149 H11
3104 D2	7150 H11
3105 F1	7151 H11
3106 F1	7152 H11
3107 G1	7153 H11
3108 G1	7154 H11
3109 G1	7155 H11
3110 G1	7156 H11
3111 G1	7157 H11
3112 H3	7158 H11
3113 H3	7159 H11
3114 H3	7160 H11
3115 H3	7161 H11
3116 H3	7162 H11
3117 H3	7163 H11
3118 H4	7164 H11
3119 H3	7165 H11
3120 H4	7166 H11
3121 H4	7167 H11
3122 H4	7168 H11
3123 H4	7169 H11
3124 H4	7170 H11
3125 H4	7171 H11
3126 H5	7172 H11
3127 H4	7173 H11
3128 H5	7174 H11
3129 H4	7175 H11
3130 H5	7176 H11
3131 H5	7177 H11
3132 H5	7178 H11
3133 H5	7179 H11
3134 H5	7180 H11
3135 H5	7181 H11
3136 H5	7182 H11
3137 H5	7183 H11
3138 H5	7184 H11
3139 H5	7185 H11
3140 H7	7186 H11
3141 H6	7187 H11
3142 H6	7188 H11
3143 H6	7189 H11
3144 H6	7190 H11
3145 H6	7191 H11
3146 H6	7192 H11
3147 H6	7193 H11
3148 H6	7194 H11
3149 H5	7195 H11
3150 C7	7196 H11
3151 E8	7197 H11
3152 E8	7198 H11
3153 E8	7199 H11
3154 E8	7200 H11
3155 E8	7201 H11
3156 E8	7202 H11
3157 F8	7203 H11
3158 H7	7204 H11
3159 H7	7205 H11
3160 D11	7206 H11
3161 D11	7207 H11
3162 D11	7208 H11
3163 E1	7209 H11
3164 E8	7210 H11
3165 E8	7211 H11
3166 F8	7212 H11
3167 G10	7213 H11

\* RESERVED  
 # Only use with FLI2310  
 V DC vtg measured in STOP-MODE

BARE BOARD : 3139-243-30624

P-Scan Board: Encoder

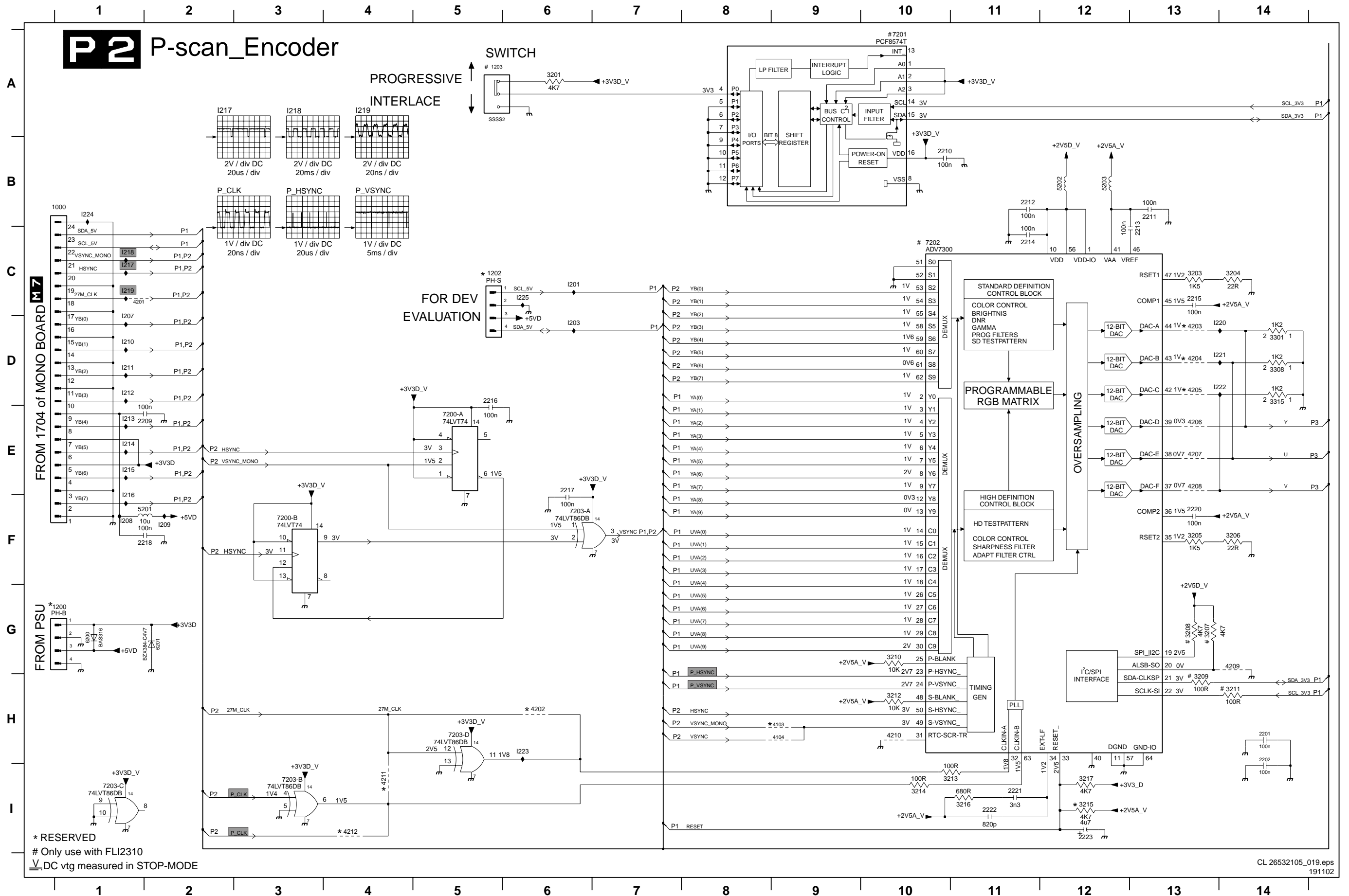

\* RESERVED  
 # Only use with FLI2310  
 V<sub>DC</sub> vtg measured in STOP-MODE

P-Scan Board: Video Output

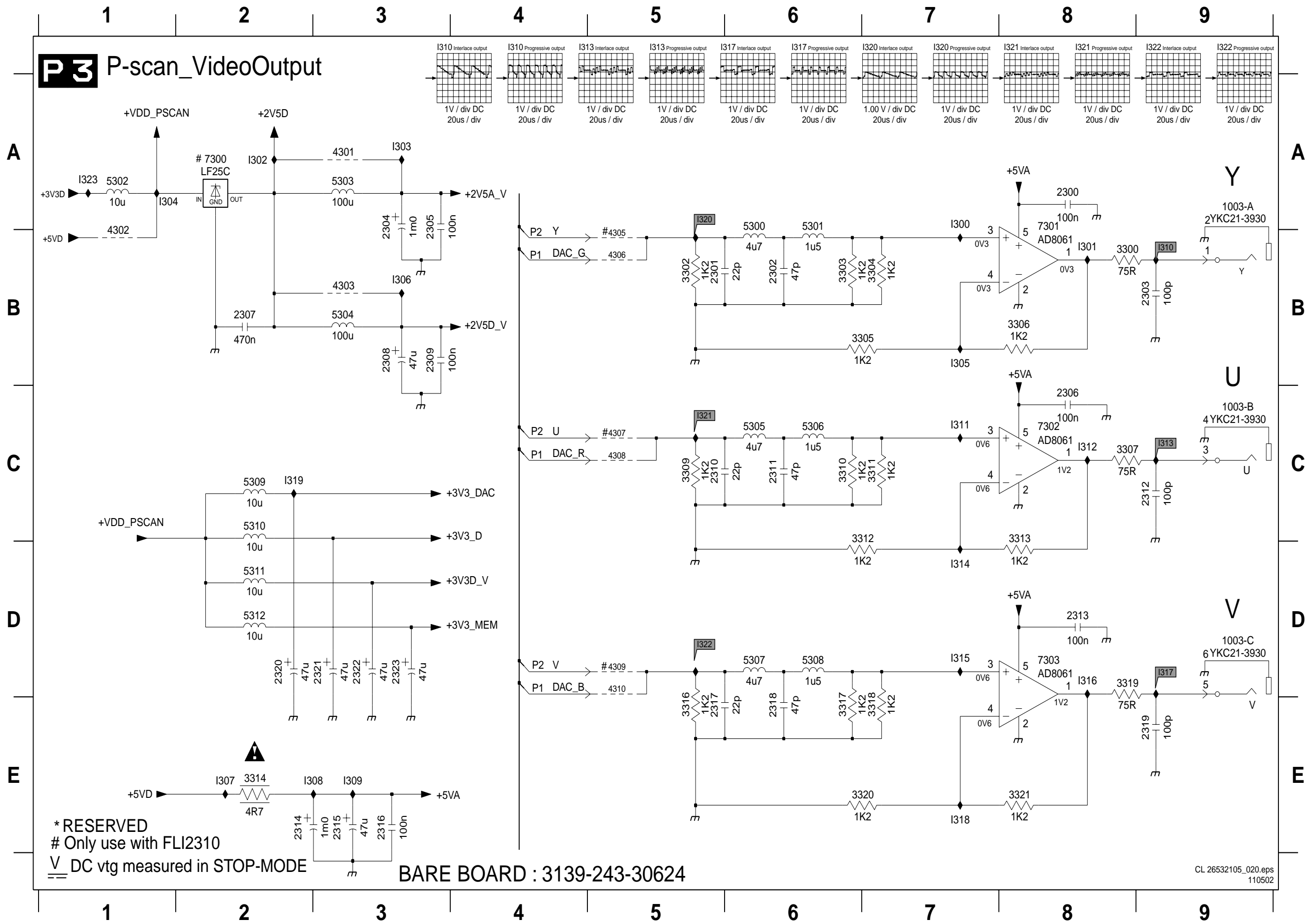

\* RESERVED  
# Only use with FLI2310

V<sub>DC</sub> vtg measured in STOP-MODE

BARE BOARD : 3139-243-30624

CL 26532105\_020.eps  
110502



Layout P-Scan Board (Overview Top Side)

1000 E3	2114 C10	2140 B4	2223 E13	2322 E12	3114 B6	3128 C6	3142 D5	3156 C12	3176 B12	3301 B15	4208 C14	7101 C4
1003 D17	2115 C9	2144 B4	2300 C16	2323 D4	3115 D5	3129 D5	3143 D5	3157 C12	3177 B11	3302 C15	4211 G11	7103 G6
1200 G5	2116 C8	2145 B4	2301 C15	3100 F11	3116 B7	3130 D4	3144 D5	3158 C6	3178 B12	3303 B15	4305 B15	7200 G12
1202 C2	2119 G9	2146 B3	2302 C15	3101 F11	3117 D5	3131 D4	3145 C6	3159 C6	3179 B11	3304 B15	4306 C15	7202 C13
1203 G16	2123 G9	2148 E11	2304 C15	3102 F11	3118 D5	3132 D4	3146 D4	3160 B6	3180 B12	3311 D15	4309 E15	7203 F12
2100 F6	2124 D11	2149 F11	2306 D15	3105 C9	3119 B6	3133 C6	3147 D4	3161 B6	3181 B11	3318 F15	4310 E15	7300 F14
2101 G8	2126 C9	2150 F12	2308 E14	3106 C8	3120 C6	3134 C6	3148 D5	3162 B6	3182 B12	4100 C9	5100 F5	7301 C15
2103 F7	2127 C10	2201 A3	2311 E15	3107 C8	3121 C6	3135 D4	3149 D4	3163 C6	3183 F12	4101 C9	5101 F6	7302 D15
2105 F11	2129 G10	2202 G2	2313 F15	3108 C8	3122 D6	3136 D4	3150 G10	3164 C12	3204 B14	4202 F13	5300 C15	7303 F15
2106 F11	2133 B5	2210 G13	2314 F14	3109 B7	3123 D6	3137 D4	3151 D12	3165 C12	3205 D14	4203 B14	5302 G14	
2107 G8	2134 E11	2216 F13	2315 G16	3110 B6	3124 D6	3138 C6	3152 D12	3166 C12	3206 D14	4204 C14	5308 F15	
2108 E12	2135 F11	2217 F13	2318 F15	3111 B7	3125 D6	3139 D4	3153 C12	3173 C11	3212 B14	4205 C14	5310 F6	
2110 G9	2136 E11	2221 D14	2320 D12	3112 B7	3126 C6	3140 C6	3154 C12	3174 C12	3213 D13	4206 C14	6201 G5	
2111 G10	2139 E11	2222 D14	2321 G7	3113 B6	3127 C6	3141 D4	3155 C12	3175 C11	3216 D14	4207 C14	7100 E9	

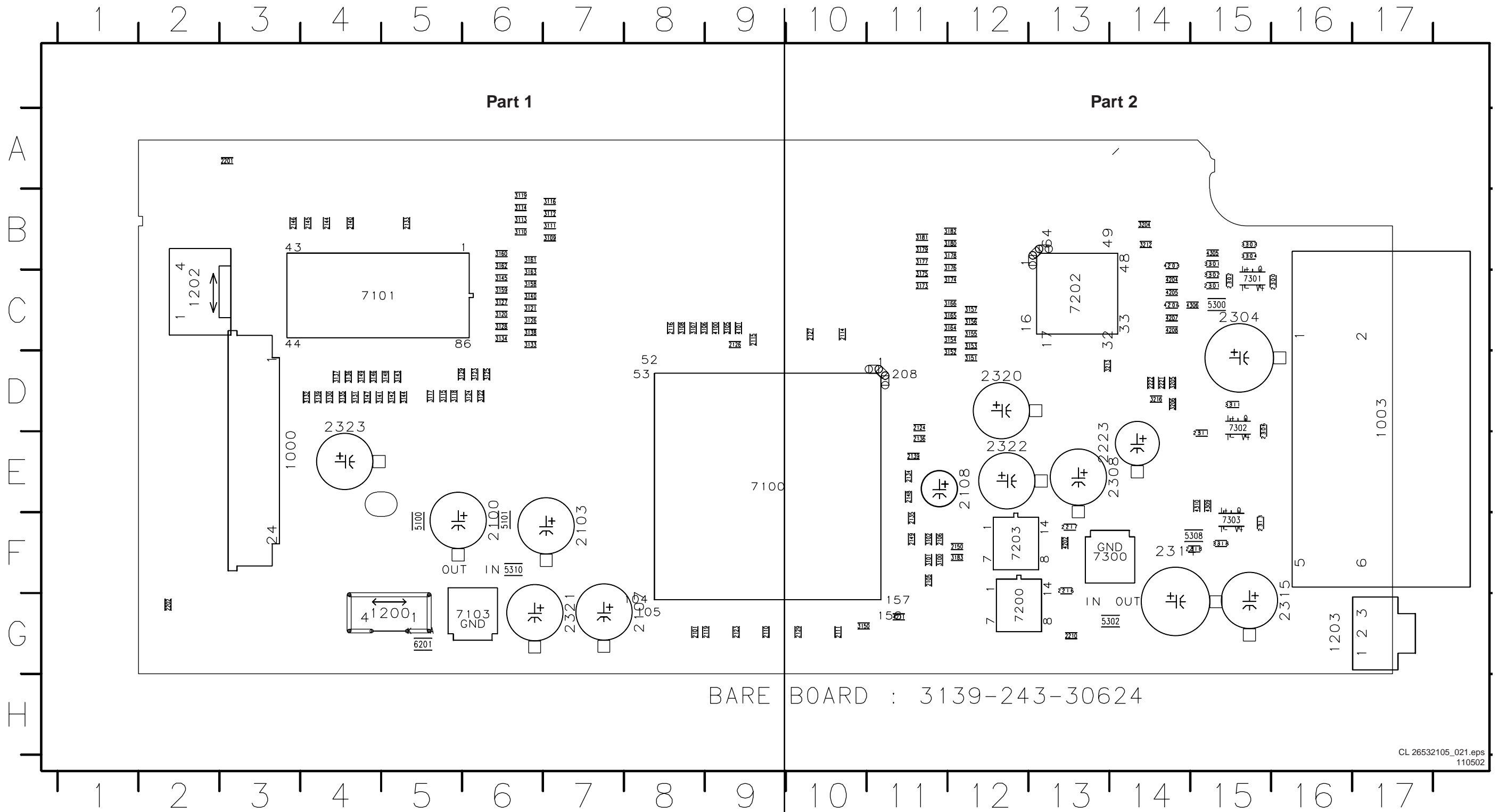



Layout P-Scan Board (Part 2 Top Side)

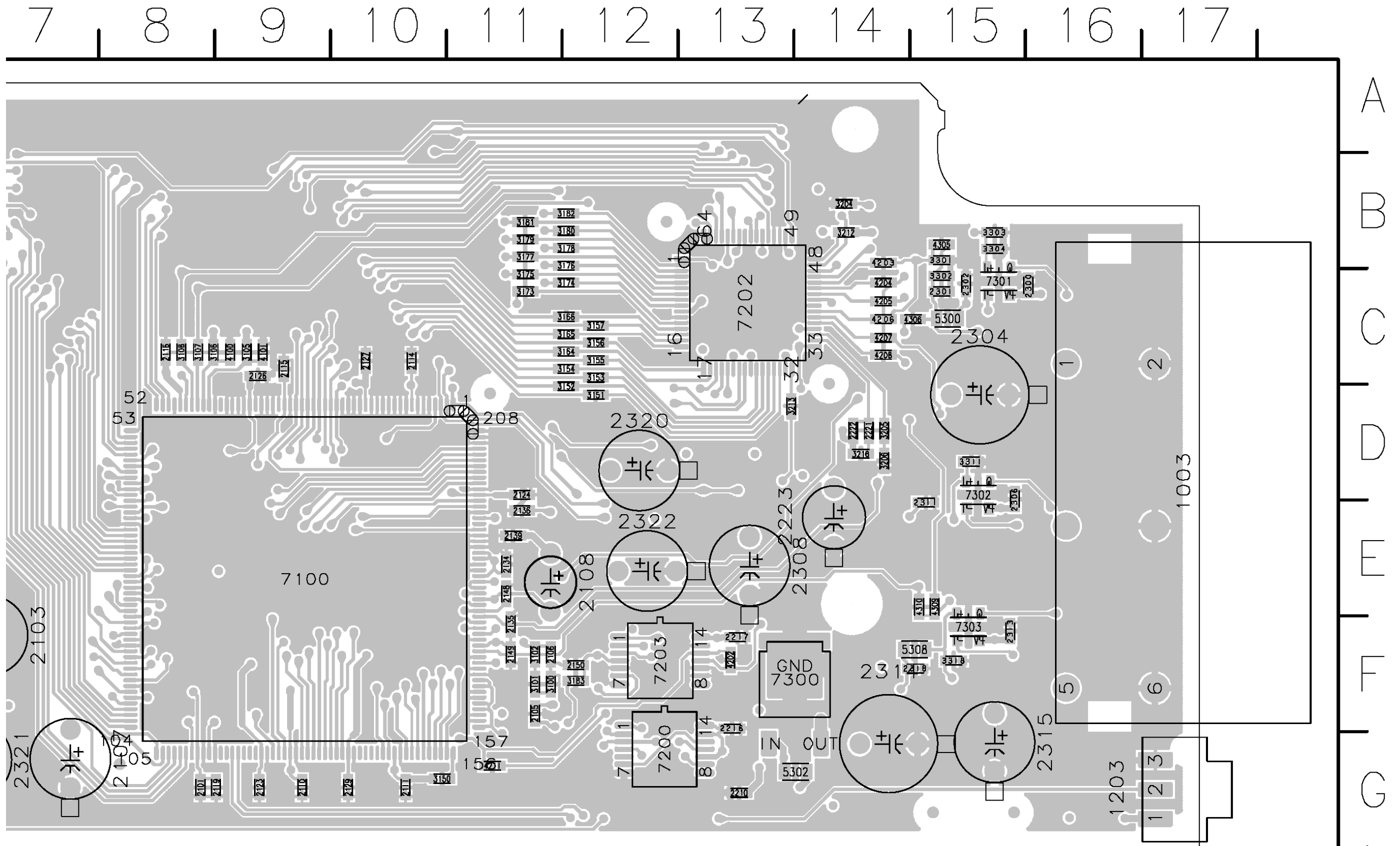

BARE BOARD : 3139-243-30624

Layout P-Scan Board (Overview Bottom Side)

2102 F12	2118 D10	2128 E10	2138 E10	2209 D16	2215 B4	2307 F4	2317 F3	3168 C16	3201 G2	3210 D5	3300 C2	3309 D3	3315 C3	3321 F3	4209 D5	4303 E4	5202 C5	5305 D3	5312 E14
2109 E7	2120 F7	2130 C12	2141 C13	2211 C4	2218 E16	2309 E5	2319 F2	3169 C16	3203 B4	3211 D5	3305 C2	3310 E3	3316 F3	4103 C8	4210 D4	4307 D3	5203 B4	5306 E3	6200 G13
2112 F10	2121 F7	2131 C13	2142 C14	2212 C5	2220 C4	2310 D3	3103 D8	3170 F14	3207 D5	3214 B5	3306 C2	3312 D2	3317 F3	4104 B8	4212 F6	4308 D3	5301 B3	5307 F3	7121 F14
2113 F7	2122 F10	2132 C13	2143 C14	2213 B4	2303 C2	2312 D2	3104 D8	3171 F13	3208 D5	3215 D4	3307 D2	3313 E2	3319 F2	4105 D8	4301 F4	5102 G11	5303 F4	5309 E6	7122 F13
2117 G7	2125 E10	2137 F7	2147 C13	2214 B5	2305 C3	2316 G3	3167 G14	3172 F14	3209 D5	3217 C9	3308 C3	3314 G4	3320 E3	4201 E14	4302 G4	5201 D16	5304 F5	5311 F6	7201 G5

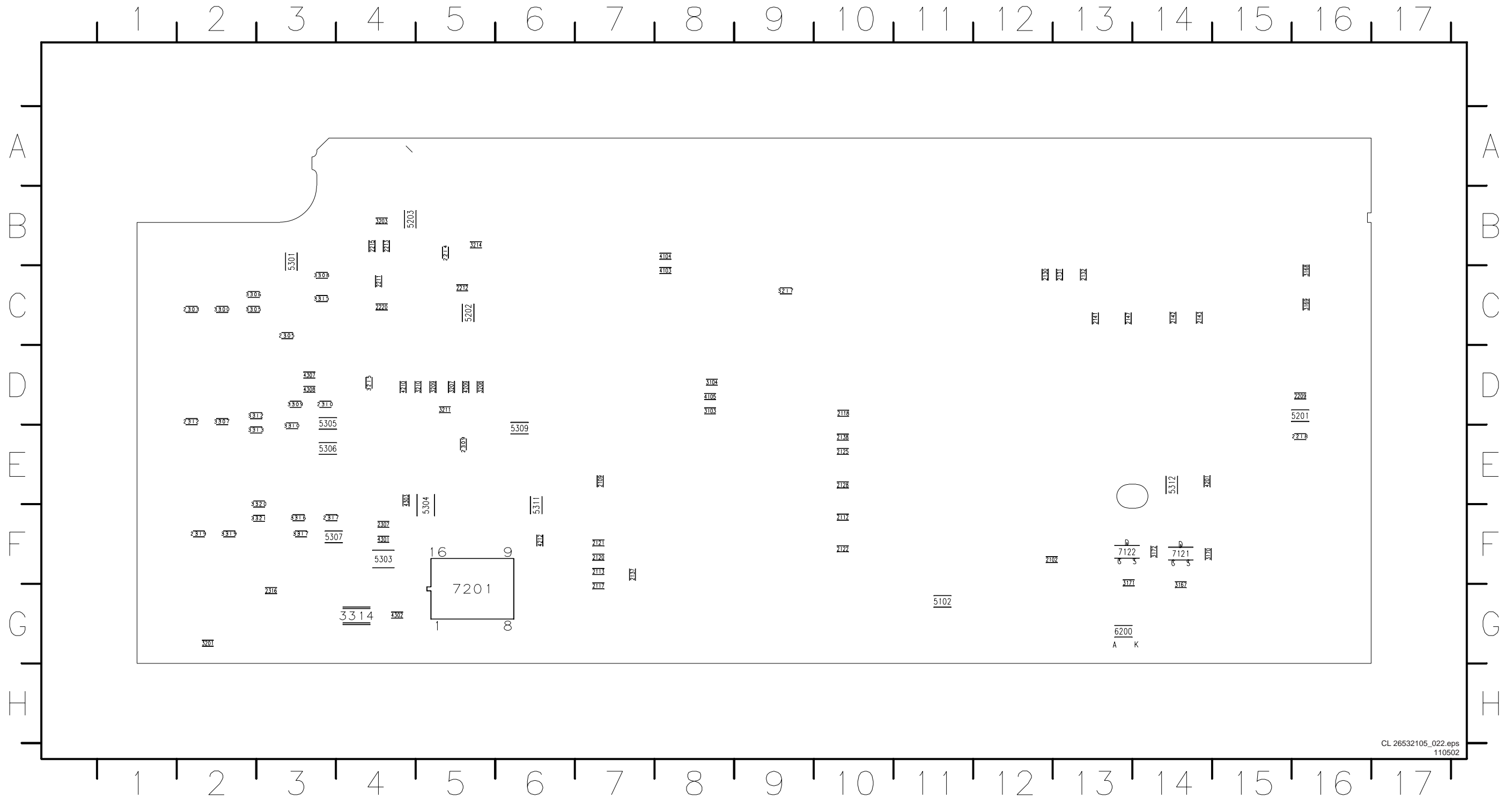

Layout P-Scan Board (Part 1 Bottom Side)

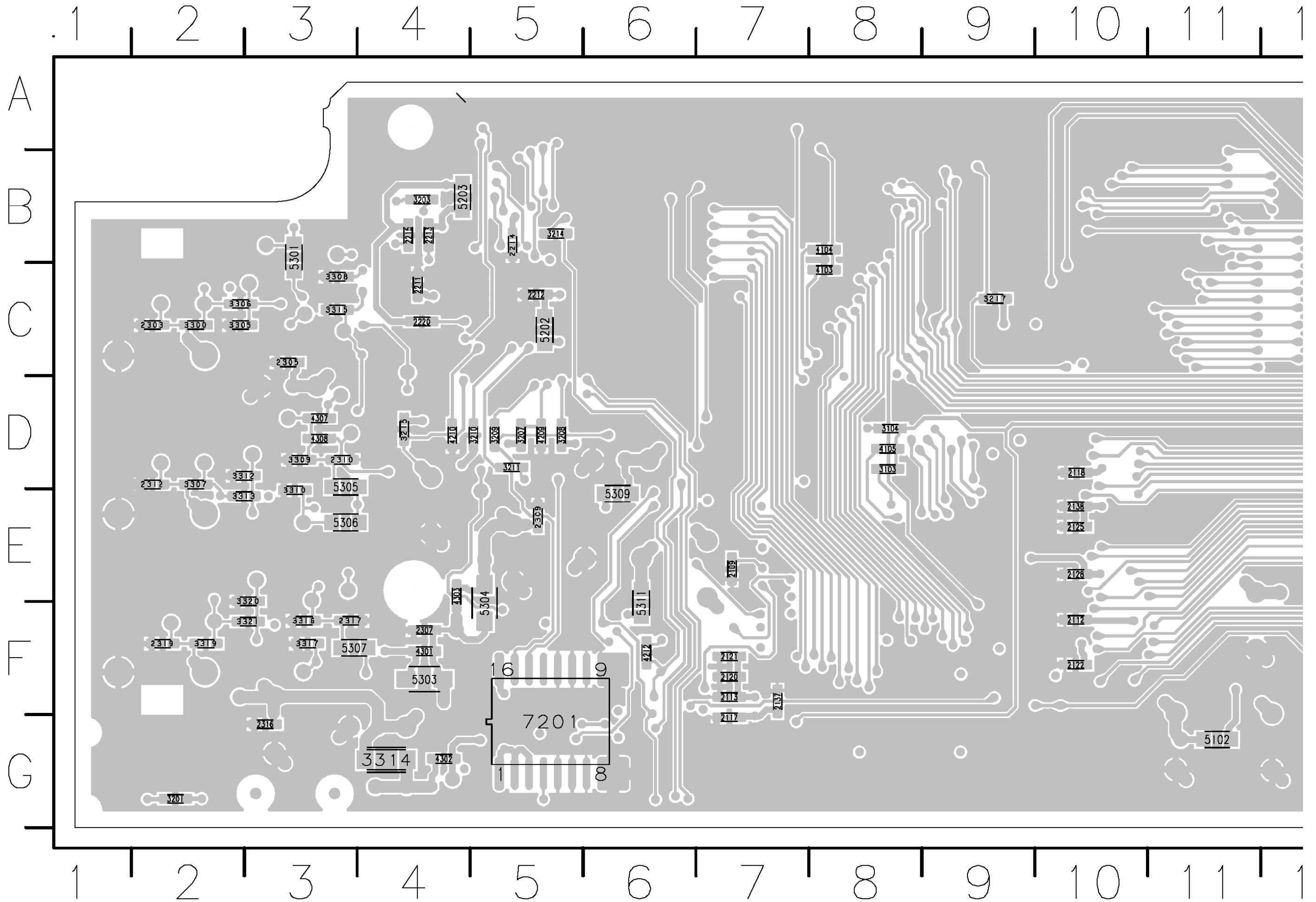

Layout P-Scan Board (Part 2 Bottom Side)

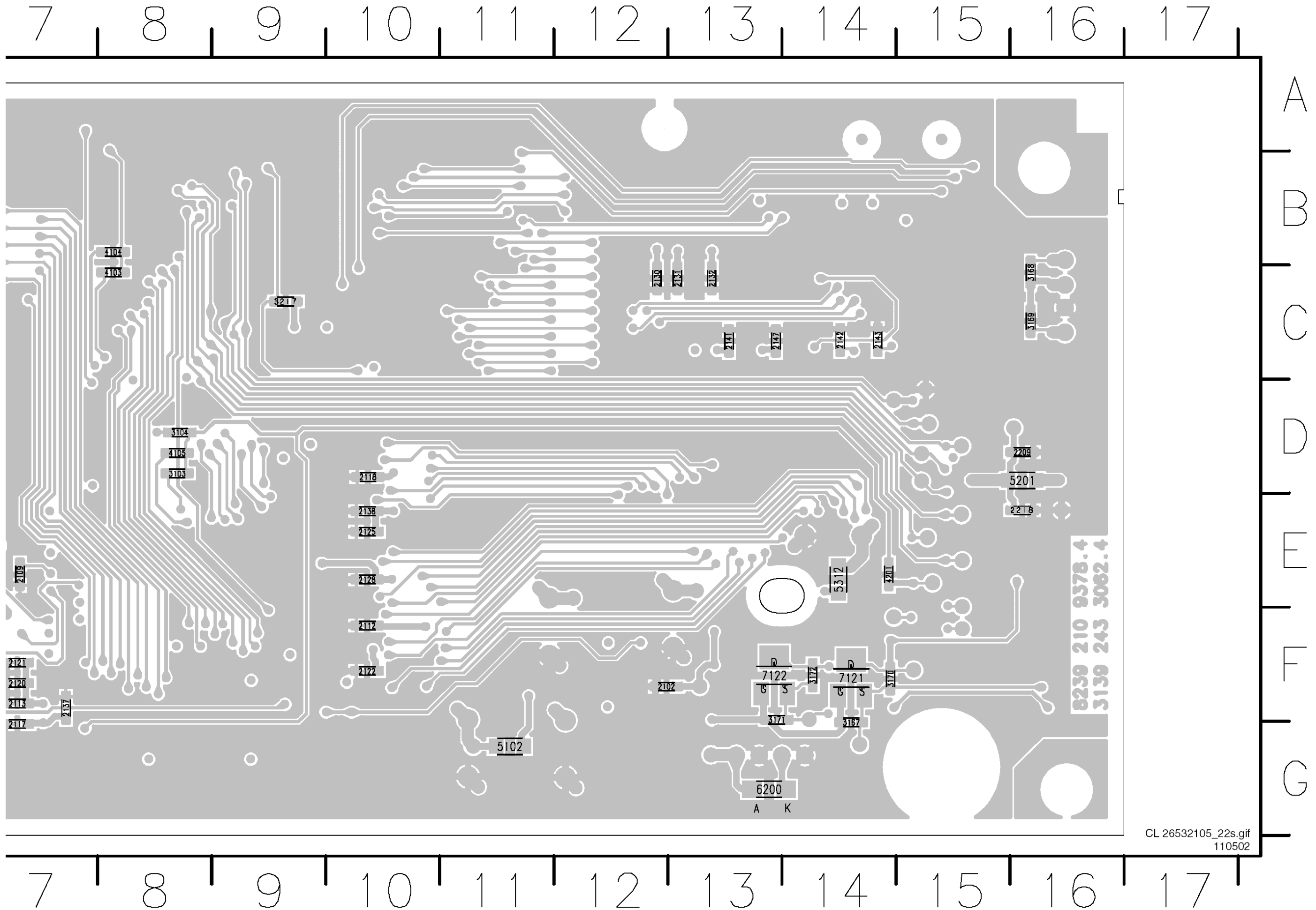

Standby Board

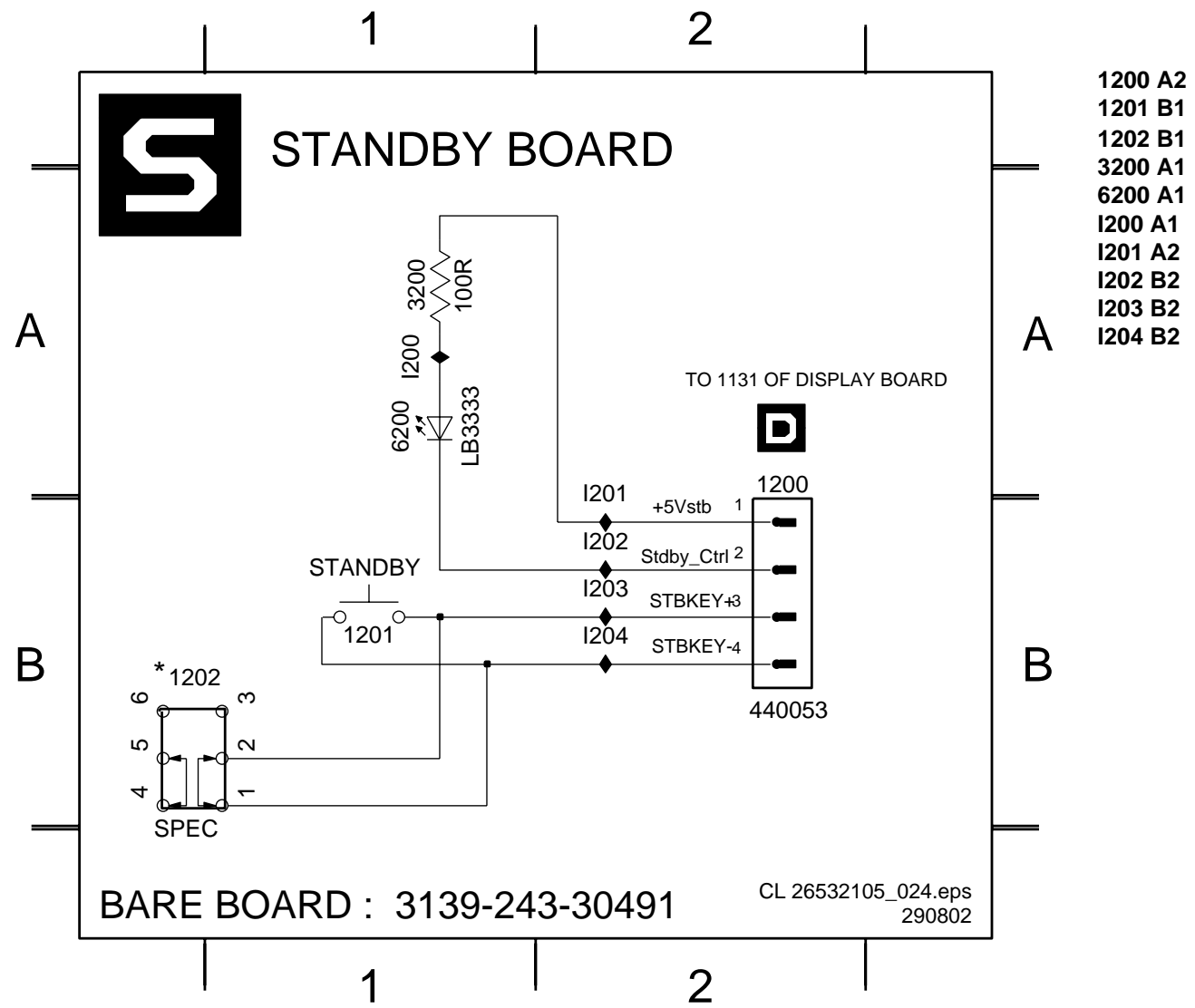

Layout Standby Board (Top Side)

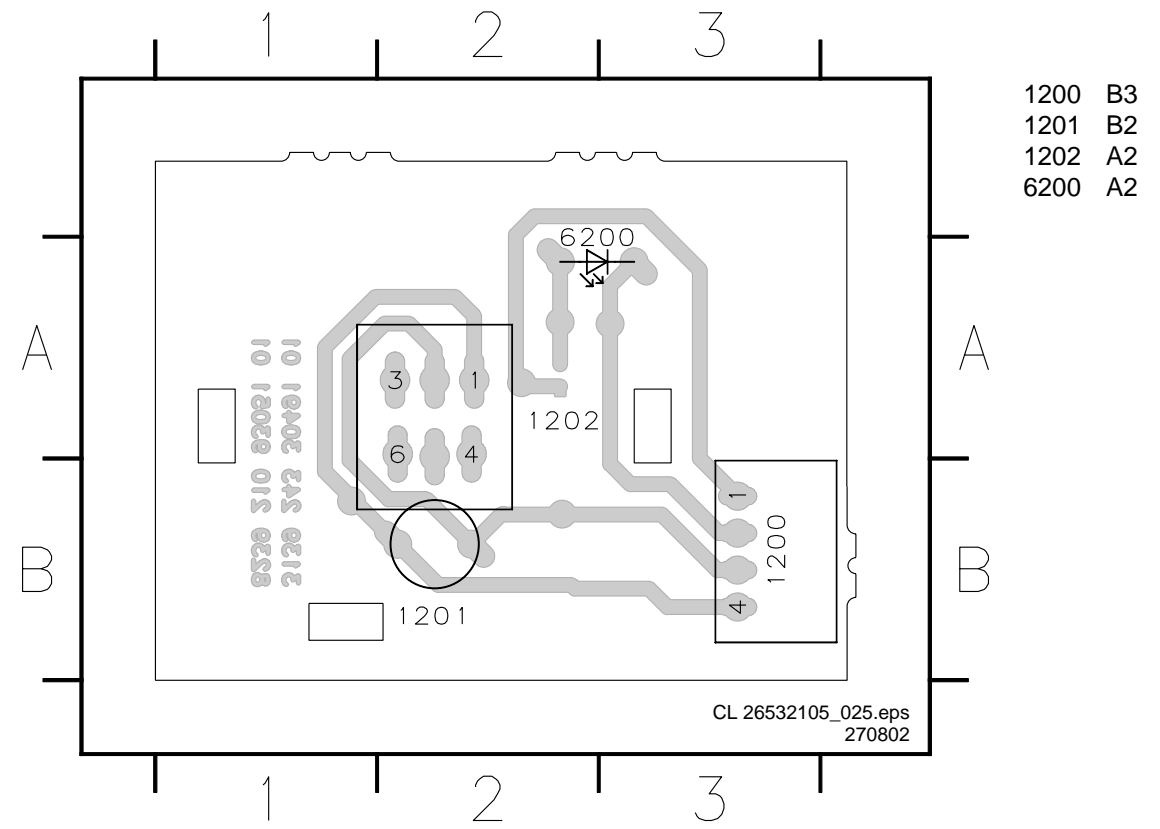

Layout Standby Board (Bottom Side)

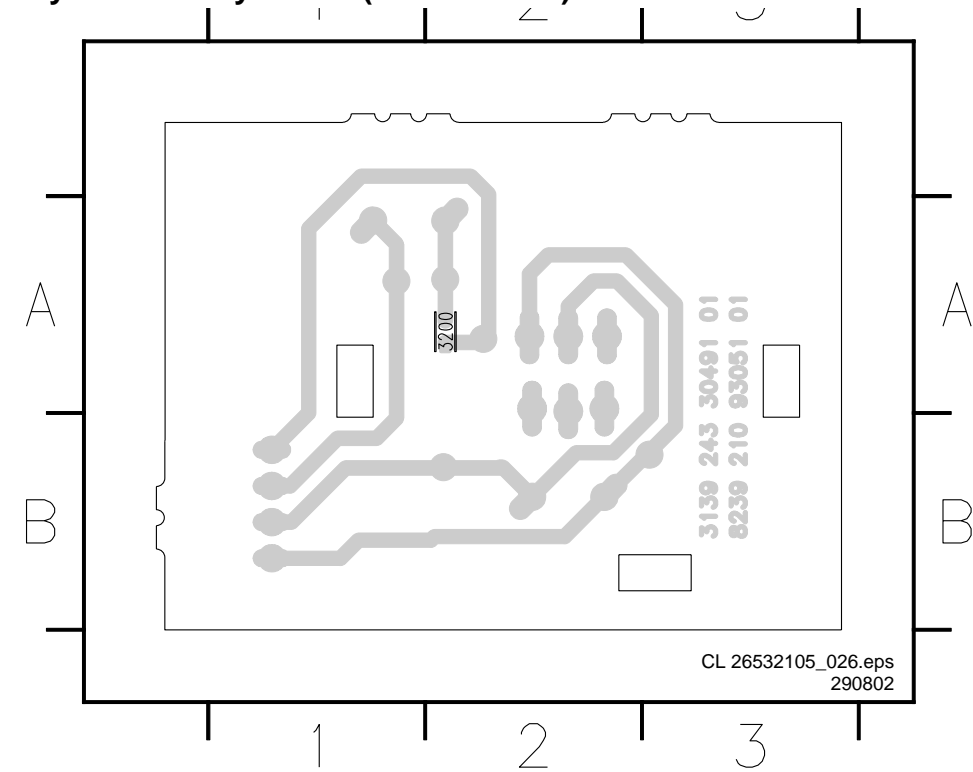

Double SCART Panel: Switching (Only for EU models)

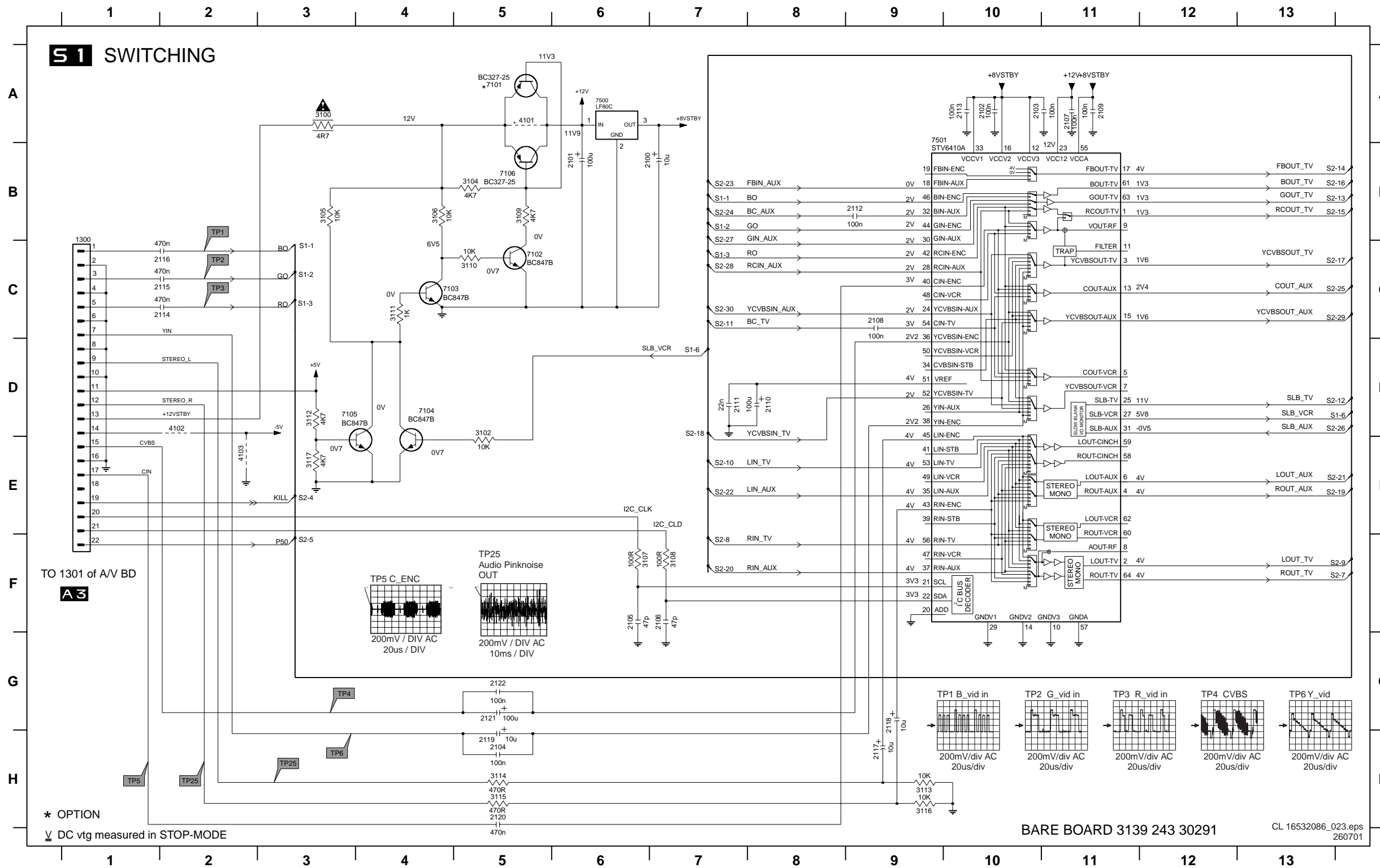

- 1300 C1
- 2100 B7
- 2101 B6
- 2102 A10
- 2103 A10
- 2104 H5
- 2105 F6
- 2106 F7
- 2107 A11
- 2108 C9
- 2109 A11
- 2110 D8
- 2111 D7
- 2112 B9
- 2113 A10
- 2114 C2
- 2115 C2
- 2116 C2
- 2117 H9
- 2118 G9
- 2119 H5
- 2120 H5
- 2121 G5
- 2122 G5
- 3100 A3
- 3102 D5
- 3104 B5
- 3105 B3
- 3106 B4
- 3107 F6
- 3108 F7
- 3109 B5
- 3110 C5
- 3111 C4
- 3112 D3
- 3113 H9
- 3114 H5
- 3115 H5
- 3116 H9
- 3117 E3
- 4101 A5
- 4102 D2
- 4103 E2
- 7101 A5
- 7102 C5
- 7103 C4
- 7104 D4
- 7105 D3
- 7106 B5
- 7500 A6
- 7501 B9

TO 1301 of A/V BD  
A3

\* OPTION  
DC vtg measured in STOP-MODE

BARE BOARD 3139 243 30291  
CL 16532086\_023.eps  
260701



Double SCART Panel: Switching (Only for EU models)

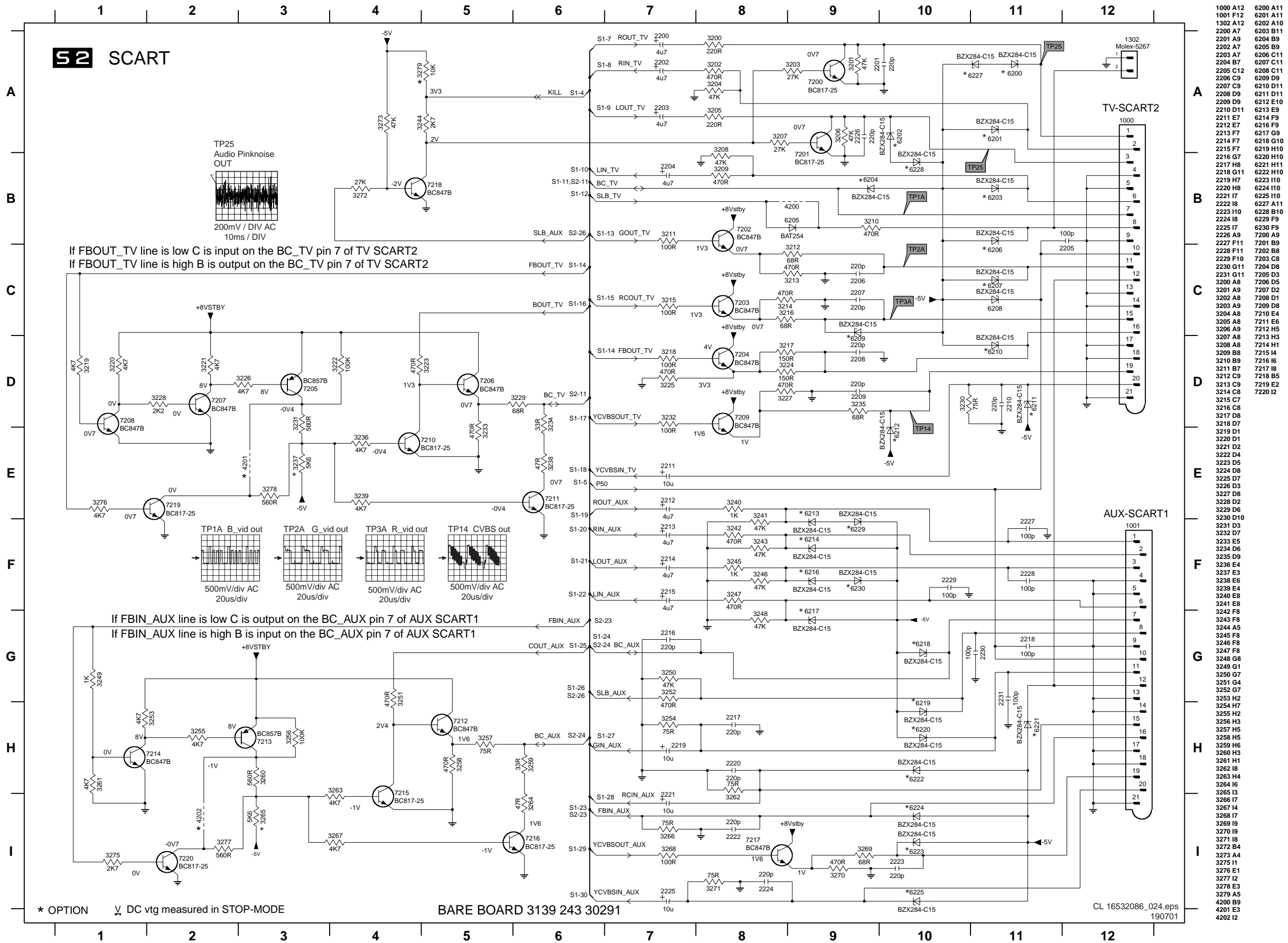

Layout Double SCART panel (Only for EU models) (Overview Top Side)

10000	D3	21116	A4	22213	C	3100	A8	32004	D4	32205	C4	3244	C4	3264	B9	4202	B10	6220	D7	7205	A3
10001	D7	21117	B4	22214	C	3100	A8	32004	D4	32205	C4	3244	C4	3264	B9	4202	B10	6220	D7	7205	A3
10002	A5	21118	B4	22215	C	3100	A8	32004	D4	32205	C4	3244	C4	3264	B9	4202	B10	6220	D7	7205	A3
10003	A5	21119	B4	22216	C	3100	A8	32004	D4	32205	C4	3244	C4	3264	B9	4202	B10	6220	D7	7205	A3
10004	B7	21120	A	22217	C	3100	A8	32004	D4	32205	C4	3244	C4	3264	B9	4202	B10	6220	D7	7205	A3
10005	A8	21121	B	22218	C	3100	A8	32004	D4	32205	C4	3244	C4	3264	B9	4202	B10	6220	D7	7205	A3
10006	A8	21122	B	22219	C	3100	A8	32004	D4	32205	C4	3244	C4	3264	B9	4202	B10	6220	D7	7205	A3
10007	B5	21123	B	22220	C	3100	A8	32004	D4	32205	C4	3244	C4	3264	B9	4202	B10	6220	D7	7205	A3
10008	B5	21124	B	22221	C	3100	A8	32004	D4	32205	C4	3244	C4	3264	B9	4202	B10	6220	D7	7205	A3
10009	B5	21125	B	22222	C	3100	A8	32004	D4	32205	C4	3244	C4	3264	B9	4202	B10	6220	D7	7205	A3
10010	B5	21126	B	22223	C	3100	A8	32004	D4	32205	C4	3244	C4	3264	B9	4202	B10	6220	D7	7205	A3
10011	B5	21127	B	22224	C	3100	A8	32004	D4	32205	C4	3244	C4	3264	B9	4202	B10	6220	D7	7205	A3
10012	B5	21128	B	22225	C	3100	A8	32004	D4	32205	C4	3244	C4	3264	B9	4202	B10	6220	D7	7205	A3
10013	B5	21129	B	22226	C	3100	A8	32004	D4	32205	C4	3244	C4	3264	B9	4202	B10	6220	D7	7205	A3
10014	B5	21130	B	22227	C	3100	A8	32004	D4	32205	C4	3244	C4	3264	B9	4202	B10	6220	D7	7205	A3
10015	A4	21131	B9	22228	C	3100	A8	32004	D4	32205	C4	3244	C4	3264	B9	4202	B10	6220	D7	7205	A3

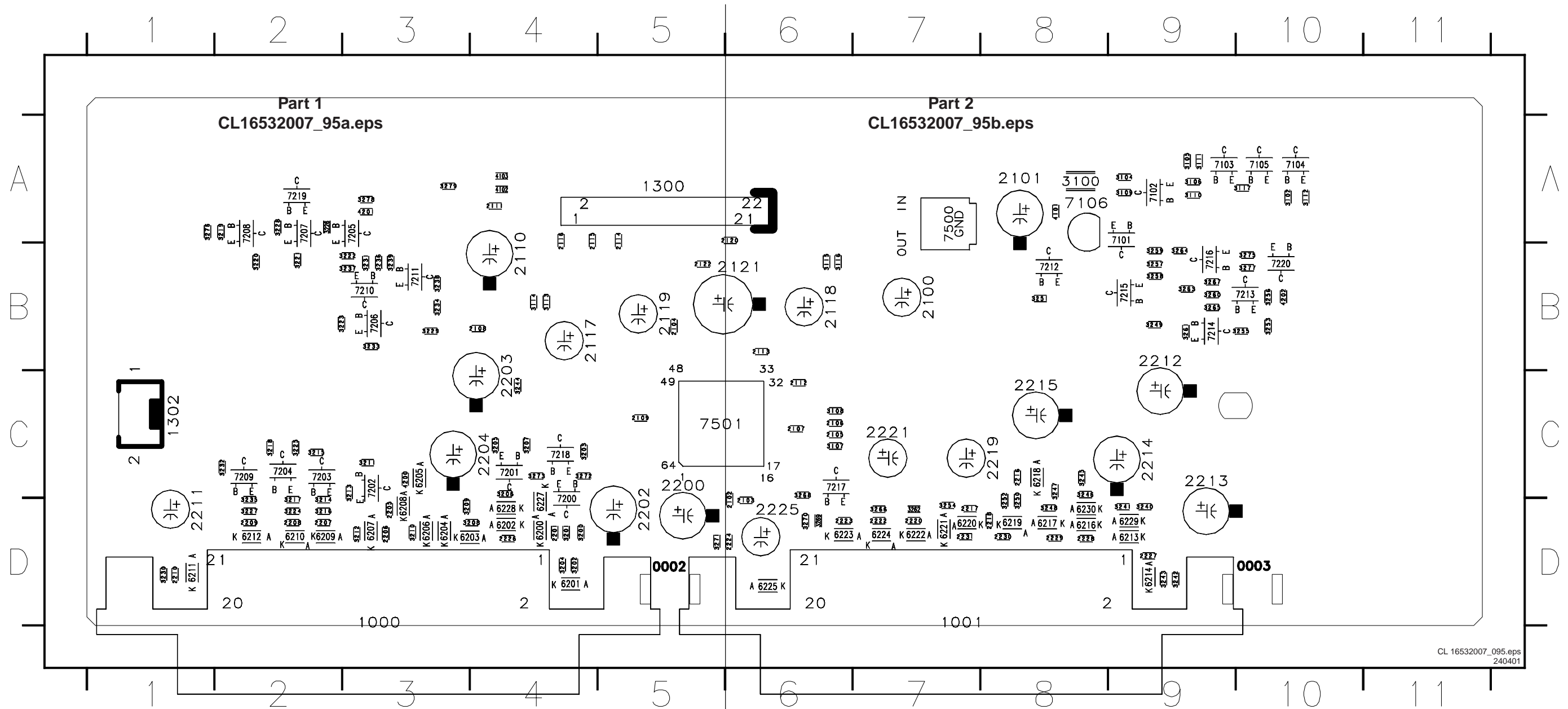





## 8. Alignments

Not applicable.

## 9. Circuit Descriptions and List of Abbreviations

Index of this chapter:

1. Introduction
2. Power Supply Unit (PSU).
3. Loader/Mono Board.
4. Audio Video (A/V) Board.
5. Front Display Board.
6. Abbreviations
7. IC Data

### Notes:

- See also the SD4.00SA\_CH Service Manual (3122 785 12480).
- Figures can deviate slightly from the actual situation, due to different set executions.
- For a good understanding of the following circuit descriptions, please use the diagrams in chapter 6 and 7. Where necessary, you will find a separate drawing for clarification.

### 9.1 Introduction

The DVD963SA is a model from the SACD 2002 'single disc' range. It uses a 2nd generation Philips SACD mono board, based on the Furore 2 DSD/DST decoder.

Below you will find a circuit description of the several modules.

### 9.2 Power Supply Unit

#### 9.2.1 Introduction

This supply is a Switching Mode Power Supply (SMPS), which uses the control IC TY720xx to produce pulses to drive the power 'switch' (MOSFET). The TY720xx (IC7130) is a high performance, current mode controller for DC-to-DC converter applications.

The operation frequency varies with the circuit load. When the output power demand decreases, the switching frequency raises, with a maximum frequency of 125 kHz (defined by C2130 at pin 5). At this point, the internal VCO takes over and starts to decrease the switching frequency.

This has some benefits compared to a 'fixed frequency' flyback converter. The efficiency is better, which results in a lower power consumption.

#### 9.2.2 Output Voltages

The following output voltages are present on connector 0201:

- Pin 1 and 2: +3V3.
- Pin 4: +12V
- Pin 5: +12STBY.
- Pin 7: +5V.
- Pin 9: -12V.
- Pin 11: -32V.

**Note:** The suffix 'STBY' indicates that the supply is not switched 'off' during Standby Mode. Power switching is done with the STBY\_CTRL signal from the slave processor.

#### 9.2.3 Operation

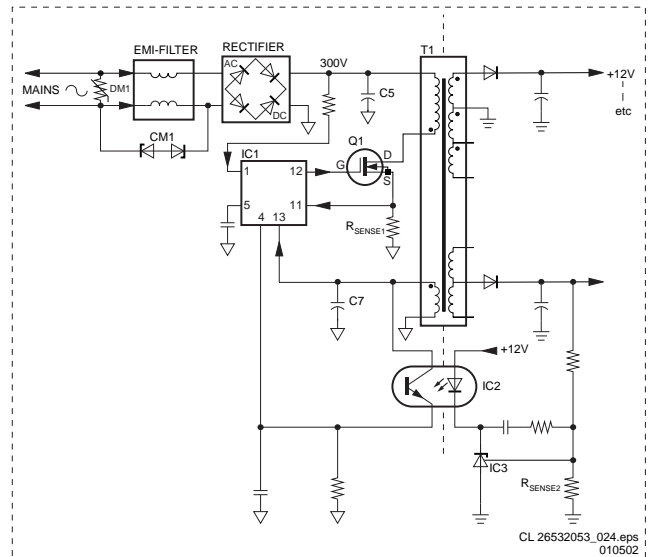

Figure 9-1 Power Supply

#### Mains Input Circuit

The bridge rectifier D6110 rectifies the mains voltage, after which C5 (2117) smoothens it. The DC voltage across this capacitor is the DC input voltage (approximately 300V), to pin 1 of transformer T1 (pin 9 of 5190) and pin 1 of IC1 (7130). The mains input also consists of a (differential mode) lightning protection DM1 (R3110) and a (common mode) lightning protection CM1 (D6114/15).

#### Start-up Circuitry

The rectified voltage from the bridge rectifier is connected to pin 1 of IC1. This voltage will charge the Vcc capacitor C7 (C2131). When this voltage, (at pin 13), reaches the start-up threshold of min. 15V, the control circuit starts to operate. After start-up, the control IC requires a sinking current, which the start-up circuitry cannot deliver. Therefore a take-over circuitry (a coupled winding of transformer T1) is present. The voltage at this point will take over the supply voltage at pin 13 of the IC1(7130).

If the take-over circuit does not function, IC1 (7130) will switch 'off' again at the minimal operating voltage of +8V. The whole operation cycle will repeat itself with audible hiccup sound if take-over is not present.

#### Secondary Voltage Sensing

The secondary voltage regulating circuit comprises of optocoupler IC2 (7190), which isolates the error signal from the control IC on the primary side, and a reference component IC3 (7290, TL431).

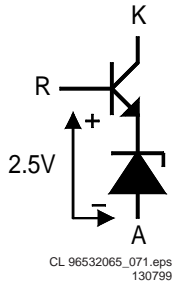

Figure 9-2 TL431

This reference component has two functions:

- A very stable and accurate reference diode
- A high gain amplifier.

When the output voltage increases (due to a reduction in the load), the voltage across  $R_{SENSE-2}$  (R3290/R3291) increases to above the internal reference voltage of 2.5V. The TL431 will conduct and the current through the opto-coupler will increase. This results in an increase of the voltage at pin 4 of IC1, which will reduce the 'on' time of Q1 (FET 7125). In the event of an output voltage decrease (due to an increase in the load), the control circuit will operate in the opposite way.

#### Primary Current Sensing

The current through FET Q1 will result in a voltage drop across  $R_{SENSE-1}$  (R3120-23). This line goes to pin 11 of IC7130, which is the current sense input. The higher the input voltage, the more the primary current is limited. In this way, the maximum output power of the power supply is limited.

#### Under-voltage Protection

If the supply voltage at pin 13 of IC7130 drops below 7.2V (typical), e.g. due to a shorted secondary voltage or excessive load, the drive pulse at pin 12 is disabled and the controller will switch 'off'.

#### Over-voltage Protection

An internal over-voltage protection circuitry continuously monitors the  $V_{cc}$  pin. If, after start-up, this voltage exceeds 40V, the internal latch circuit is triggered, the output buffer is disabled, and the SMPS goes into over-voltage protection. Now a complete restart sequence is required.

**Note:** If the event of the over-voltage situation remains present, the SMPS will go in sequence of protection, start-up, protection and the cycle repeats. This effect is highly audible.

### 9.3 Loader/Mono Board (for diagrams see SD4.00SA\_CH Service Manual)

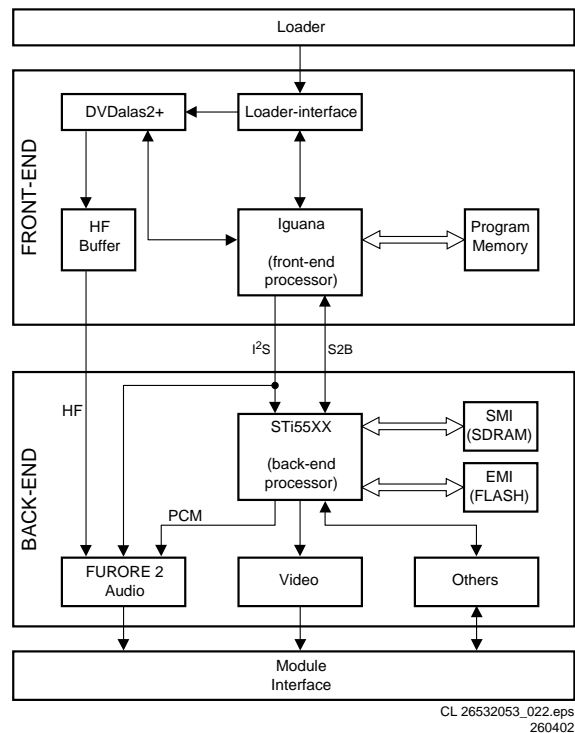

Figure 9-3 Block Diagram Loader/Mono board

The SD4.00\_SA\_CH (SACHI\_4) is the 2nd generation Philips Architectural Standard Design of SACD mono board based on Fureore 2, and will be used in the new generation of SACD players. It is designed in a multi-task way so that it can support the following optional main functions:

- SD4.00\_SA\_CH: Support SACD player with 5-disc changer.
- SD4.00\_SA: Support SACD player with single-disc.
- SD4.00\_CH: Support DVD player with 5-disc changer but without SACD playback.
- SD4.00\_SA\_I2C: Support SACD player with single-disc and I2C slave.

The SD4.00\_SA\_CH (SACHI\_4) module consist of the following key components:

1. **OPU:** Mercury 2 Loader VAL6011/14 (slim type) for a single-disc SACD player, or DVD VAM6001/14 mechanism for a 5-disc SACD changer.
2. **Front-end:** M2 Basic Engine.
3. **Back-end:** DVD Host Processor STI55xx and Fureore 2 SACD DSD/DST decoder.
4. **Power supply:** To convert the PSU voltages to the correct values.
5. **Reset circuit:** This circuit that the booting of the several devices on the mono board takes place in the correct order.

#### 9.3.1 The Optical Pick-up Unit (OPU)

The Mercury 2 Loader has an optical unit consisting of two lasers:

- One for CD with a wavelength of 780 nm.
- One for DVD with a wavelength of 650 nm.

The TZA1033 (item 7105) controls the data from these lasers, and the supply to them.

#### 9.3.2 Front-end: the Servo Part

The front-end consists of:

- The Loader interface

- The Servo Processor/Decoder
- The Interface/Program Memory

#### The Loader Interface

The TZA1033HL/K2 (or DVDALAS2plus, item 7105) is an analogue pre-processor and laser supply circuit. It contains data amplifiers and several options for radial tracking and focus control.

It is possible to optimise the dynamic range of this pre-amp/processor combination for the LF servo and RF data paths. The gain in both channels is separately programmable. This will guarantee an optimal playability for all kind of discs.

Also, a dual laser supply is implemented, with fully automatic laser control including stabilisation and an ON/OFF switch, plus a separate supply pin for power efficiency.

#### The Servo Processor/Decoder

In the SD3.0 module, the servo signals were fed to the MACE2 servo processor, while the HF output signal was fed to the SAA7335 decoder. In the new SD4.0SA\_CH module, these ICs are combined into one chip: the SAA7812 Iguana.

This chip contains the following blocks: channel decoder, block decoder, servo processor, and microcontroller.

The servo circuit in the SAA7812 (item 7207) takes care of the servo controls.

In a CD system, there are some twelve control loops active. About six of them are needed to adjust the servo error signals that is once per disc rotation. It also adjusts offsets, signal amplitudes, and loop gains (AGCs), to enlarge system robustness and to avoid expensive potentiometer adjustments in production.

The other six loops determine the laser spot position on the disc in the radial, axial (focus), and tangential directions. It also has to take care that the spot accesses a required position as fast as possible. This access system consists of two parts, namely the actuator and the sled, which are (within a certain range) mechanically and electrically independent. Therefore, during an access, the servo has to control as well the actuator as the sled.

The analogue signals, from the diode pre-processor, are converted into a digital representation using A/D converters. For the communication between the host processor (STi55xx) and the servo processor, the S2B bus is used. This bus supports full-duplex asynchronous communication.

The SAA7812 is also a combined CD/DVD compatible decoding device. The device operates with built in hardware for CD/DVD error correction and de-interleaving operations. It decodes EFM or EFM+HF signals directly from the laser pre-amplifier, including analogue front-end, PLL data recovery, demodulation, and error correction.

Its analogue front-end input (the channel decoder), converts the HF input signal to the digital domain via an 8-bit ADC, preceded by an AGC circuit to obtain the optimum performance from the converter. An external resonator clocks this block. This subsystem recovers the data from the channel stream. It corrects asymmetry, performs noise filtering and equalisation, and finally recovers the bit clock and data from the channel using a digital PLL.

The demodulator part detects the frame synchronisation signals and decodes the EFM (14 bit) and EFM+ (16 bit) data and sub-code words into 8-bit symbols. Via the serial output interface, the I<sup>2</sup>S data (audio and video) go to the DVD decoder STi55xx.

The spindle-motor interface provides both motor control signals from the demodulator and, in addition, contains a tachometer loop that accepts tachometer pulses from the motor unit. They drive the motor IC (BA6665FM, item 7300).

The SAA7812 has two independent microcontroller interfaces. The first is a serial I<sup>2</sup>C-bus and the second is a standard 8-bit

multiplexed parallel interface. Both of these interfaces provide access to 32 8-bit registers for control and status.

#### The Interface/Program Memory

The interface between front-end (SAA7812) and back-end (Sti55xx) is via:

- I<sup>2</sup>S bus (BCLK, DATA, WCLK, FLAG, SYNC and V4).
- S2B bus (RXD\_S2B, TXD\_S2B, CPR\_S2B and SUR\_S2B).
- Miscellaneous I/O ports (RSTNF= front-end reset, EANF= front-end processor boot select).

**Service tip:** These lines contain series resistors (47 or 100 Ω) for easy hardware debugging, and for EMC/noise reduction of the high-speed I<sup>2</sup>S lines.

The front-end processor SAA7812 (Iguana) has two boot modes: normal boot from flash memory, or serial mode. The boot selection is via the EANF pin. The Iguana, samples the EANF signal level once during boot-up. Once boot-up is completed, this pin is no longer used for this purpose. However, in the SD4.0SA\_CH circuit, the EANF is also connected to the flash memory. Therefore, when this pin is LOW, the lower 1 Mbits of the memory is accessible. Conversely, when this pin is HIGH, the upper 1 Mbits is accessible.

Under front-end normal operation, the program memory (less than 1 Mbits in size) should reside in the lower bank. Therefore, the EANF pin should be LOW at all times. Since the actual flash memory used is 2 Mbits, the upper 1 Mbits is unused. This area is reserved for possible use by the front-end self-diagnostic software, or flash download application.

### 9.3.3 Back-end: the Digital Part

The back-end consists of:

- DVD back-end processor
- SACD DSD processor
- Audio output
- Video output
- Clock factory
- Miscellaneous

#### DVD Back-end Processor

The SD4.0SA\_CH is designed for the STi55xx family. Some of the DVD related features of these ICs are:

### Processor overview

Function	STi5580	STi5588	STi5519
Basic CD/VCD/DVD decoding	X	X	X
Extra 2-channel of I2S output (PCMDATA3)	X	X	
Karaoke	X	X	
DTS	X	X	
Audio post processing (equalizer, level meter, etc)		X	
DVD audio		X	
Progressive scan at analog video output		X	

CL 16532163\_048.eps  
020902

Figure 9-4 Processor overview

The STi5580 has the same architecture as the STi5508 (used in earlier DVD generations), and is pin-to-pin compatible.

It works on 3.3 V (V<sub>DD</sub>), and comprises the following functions:

- Video decoder, which supports MPEG1 and MPEG2.
- Audio decoder that supports AC-3, MPEG1, MPEG2, DTS, PCM, S/PDIF, and MP3.
- PAL/NTSC video encoder with simultaneously Y/C, CVBS, and RGB/YUV outputs.
- The video encoder supports Closed Caption and allows MacroVision 7.0/6.1.
- Full screen On Screen Display (OSD) generator.
- Three on-chip PLLs to generate all necessary clocks (as reference the 27 MHz video clock is used).

### Input

Input data comes from the I<sup>2</sup>S-bus. The front-end interface of this device, accepts DVD, CD and CD-DA information.

### Signal Processing

For video, the input data stream is decoded to the appropriate MPEG, Sub Picture, and OSD data streams, after which they are fed to the PAL/NTSC encoder. This cell will convert the digital MPEG/Sub Picture/OSD stream into a standard base band signal and into RGB components. It handles interlaced and non-interlaced data, can perform CC/TXT encoding, and allows MacroVision copy protection.

For audio, the processing cell is a fully compatible DTS, Dolby Digital (AC-3), MPEG1, MPEG2, PCM decoder, capable of decoding 5.1 and 2 channel streams.

### Output

For video, six analogue output pins are available on which CVBS, S-VHS (Y/C), and RGB signals are present. They go, via a buffer, to connector 1703. As an option, a digital YUV output is available at connector 1704.

### External Memory

The STi55xx family is capable of accessing external memory via three buses:

- **The enhanced memory interface (EMI).** This interface is configurable and can be used to access Flash, ROM, and various flavours of DRAM.
- **The shared memory interface (SMI).** The SMI is only used to access SDRAM. The SMI is connected to a 64Mbits (4M x 16bit) 7.5ns SDRAM (item 7500). The SDRAM has the following functions:
  - It is used by the MPEG video decoder as a frame buffer,
  - It holds the software and the variables used by it.
- **The I<sup>2</sup>C bus.** Via this bus, the NVRAM (or EEPROM) is accessible. This memory is used to store user settings, player settings, and region code. As the STi55xx I/O-lines are potentially unable handle 5V inputs, a voltage level shifter is foreseen for all I<sup>2</sup>C-busses. This circuit will isolate the STi55xx I<sup>2</sup>C ports (3.3V) from the system I<sup>2</sup>C bus (5V). See figure below.

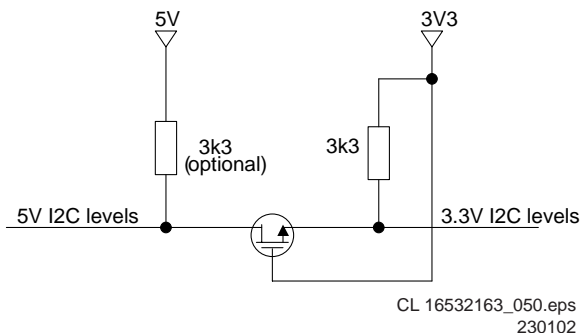

Figure 9-5 I<sup>2</sup>C voltage level shifter

### The SACD DSD processor

The Furore-IC is a one-chip design, containing all the hardware that is required for SACD processing. It is intended to interface with the STixx-family DVD video decoders.

The Furore-IC contains a memory interface to support an external 16 or 64 Mbit SDRAM.

During SACD application, the STi55xx serves as a host, whereby the Furore is controlled via the EMI interface. The Furore processing part is not used during all other play modes. In these modes, the PCM audio signals are fed through the Furore to the appropriate DAC.

### Block diagram

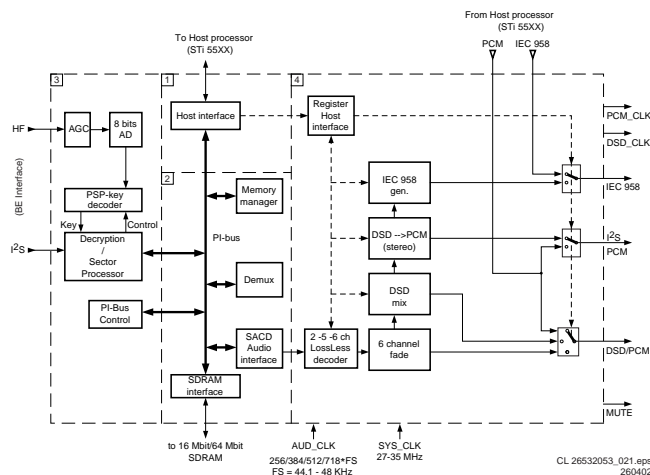

Figure 9-6 Block diagram Furore

We can divide the Furore-IC in four main parts (see block diagram):

1. **Host interface.** This is the link between the host bus and the internal registers and memory bus. It also supplies the general reset signal (HW and SW) and the interrupt signals.
2. **Data processing.** All modules and peripherals in this part are connected to a so-called PI-bus. It is beyond the scope of this manual to go more in detail on this subject.
3. **Copy protection.** On every SACD disc, a PSP-signal is recorded. The player can only play a disc if a valid PSP-signal is detected. This PSP-key is recorded, via a special mechanism, in the EFM-signal on the disc. To detect this key, the analogue HF-signal from the optical pick-up unit is fed directly to the Furore-IC. Via an AGC, the signal is fed to an ADC. The digitised HF signal is then fed to a block where key is encrypted. Control of this process is done via the host interface (sector processor).
4. **DSD decoding and post processing.** In this part, all processing is done to generate a DSD and/or an I<sup>2</sup>S stream (from the de-multiplexed stream coming from the data processing block), in such a way that it can directly be connected to a DA-converter. All processing is done on 384\*FS.

### Interfaces

- **Basic Engine Interface:**
  - Data input interface. The Basic Engine Interface (I<sup>2</sup>S) is connected to the output of the SAA7335 (HD61) high speed CD decoder.
  - Analogue HF input. The analogue HF input, coming from the optical pickup unit (OPU), is also fed to the Furore-IC, to extract the copy-protection information PSP (Pit Signal Processing = invisible data is stored on to disc, which is required to decrypt the encrypted content).
- **SDRAM Interface:** The SDRAM interface forms a glue less interface to one 64 Mbit SDRAM device. The interface takes care for the power-up sequence, mode programming and refreshing of the SDRAM devices. This is hard coded in the interface and does not have to be controlled by the host.
- **Audio data input/output Interface:**
  - DSD/PCM combined data output. DSD\_PCM: Output intended for a combined 6-channel DSD (SACD) and PCM (DVD-CDDA) DAC. Switching between the PCM data coming from the STi55xx, and the internal generated DSD signals, is done in the Furore IC.
  - Stereo DSD only output. DSD\_stereo: 2-channel DSD output with stereo down mix in the case of 5- and 6-channel, and normal stereo in case of 2-channel DSD mode.



- Stereo PCM data output. Two possible stereo sources can be selected as stereo PCM output:
  1. Stereo PCM coming from the STi55xx via the PCM input on Furore.
  2. Stereo or down-mix-PCM derived via a decimation filter from the SACD-DSD signal.
- Digital audio output interface (IEC958). The IEC958 format is intended to connect the DVD736SA to a digital receiver. No DSD signals are defined for IEC958, therefore the 'DSD-->PCM converted' signal is transmitted. Following two types of signals are possible on the digital interface:
  1. IEC958 data coming from the STi55xx.
  2. IEC958 data (stereo or down-mix-PCM) derived via a decimation filter from the SACD-DSD signal.
- Clock + reset input. Two different processing clocks and a reset pulse are needed:
  1. Sys\_clk: System clock for data processing part, frequency can be 27 MHz or 768\*FS.
  2. 384\*FS: Processing clock for LLD and post processing.
  3. RESETn is an asynchronous reset and should be low for at least 1 period of DSD\_CLK.

#### Memory

- **SDRAM.** The size of the SDRAM is 64 Mbit (items 7500 and 7502). It has the following functions:
  - It is used by the MPEG video decoder as a frame buffer,
  - It holds the software and the variables used by it.
- **Flash-ROM.** Two 2MB Flash-ROMs (items 7402 and 7403) hold the DVD firmware, and are controlled by pin 16 (FLASH\_OEN) of the STi55xx. It must be able to perform a download (by disk or OS-link) in a Flash-only system.
- **EEPROM.** User settings, player settings, and region code are stored in a 32 Kb I<sup>2</sup>C EEPROM.

#### Audio Output

The audio interfaces available in SD4.0SA\_CH are I<sup>2</sup>S and S/PDIF for digital audio output, and I<sup>2</sup>S karaoke microphone input.

In SACD player, two types of DACs (that are PCM DAC and high end DSD DAC), are used on AV board.

The audio data path to both DACs is routed via the Furore 2.

#### I<sup>2</sup>S audio

The STi55xx is capable of 6-channel I<sup>2</sup>S output. These channels can be configured to output 5.1 Dolby Digital, DTS, etc.

- PCM\_OUT0: Left and Right.
- PCM\_OUT1: Centre and LFE (subwoofer).
- PCM\_OUT2: Left and Right surround.

Two additional channels (available in STi5580 and STi5588) are capable of providing down-mixed stereo.

#### S/PDIF

The S/PDIF signal level (pin 57, SPDIF\_OUT) is 5V TTL at module interface. To meet the complete S/PDIF specifications, an external de-coupling circuit (item 7720, diagram M7) is implemented.

#### I<sup>2</sup>S karaoke (optional)

The STi5580 and STi5588 have built-in karaoke processing. The internal karaoke block accepts I<sup>2</sup>S signal, acting as the master by generating the required KOKPCMCLK frequency. This frequency is always 1/4 the music sampling frequency. An external analogue-to-digital converter (ADC), acting as slave, is required to convert the microphone signals to I<sup>2</sup>S signals.

#### CD-DA/DVD Data Path

The data path for CD-DA and DVD is as follows:

- I<sup>2</sup>S data from the M2 basic engine enters the STi55xx.

- The STi55xx processes the data, and sends the 6 PCM output channels to Furore 2. The LeRi channels are directly passed to the AV board also.
- The switch matrix of the Furore 2 sends the two incoming stereo PCM channels (LeRi) to the AV board.
- The switch matrix of the Furore 2 sends the six incoming PCM channels to the high end DAC board.
- The mute signal from the STi55xx is directly passed to the AV board. This requires a patch on the mono board.
- The IEC958 output of the STi55xx is fed directly to AV board.

The clock distribution is as follows:

- The master clock 384FS is received from the high end DAC board.
- From this clock the 27 MHz clock for STi5580 and the Furore 2 is derived (Video clock).
- From the 27 MHz clock the audio clock (256FS) is derived. The STi55xx and Furore 2 use this clock. For CD-DA FS amounts to 44.1 kHz, for DVD 48 or 96 kHz.
- In case of CD-DA, the high end DAC uses its internal clock (384FS). In case of DVD, the switch matrix of Furore 2 sends the audio clock (256FS) to the high end DAC on AV board.
- The AV board receives the 256FS clock.

Selection of the audio clock is done in the clock factory. For a description of the clock factory, see paragraph 'Clock Factory'.

#### SACD Data Path

The data path for DSD/DST is as follows:

- I<sup>2</sup>S data from the basic engine enters the Furore 2.
- The Furore 2 processes the data. This results in 6 DSD/DST channels.
- The switch matrix of the Furore 2 sends the 6 DSD/DST channels to the high end DAC on AV board.
- The 6 DSD/DST channels are down mixed to a stereo PCM signal.
- The switch matrix of the Furore 2 sends the stereo PCM signal to the AV board.
- The mute signal from the STi55xx is directly passed to the AV board. This requires a patch on the mono board.

The clock distribution is as follows:

- The master clock 384FS is received from the high end DAC on AV board.
- From this clock the 27 MHz clock for STi55xx and Furore 2 is derived (video clock).
- From the 27 MHz clock the audio clock (256FS) is derived. The STi5580 and Furore 2 use this clock.
- The high end DAC on AV board uses its own XTAL clock (384FS). The 256FS clock to the DAC board is switched off, to prevent for interference.
- The AV board receives the 256FS clock.

Selection of the audio clock is done in the clock factory. For a description of the clock factory, see paragraph 'Clock Factory'.

#### Video Output

##### Digital video (optional)

Digital YUV output is routed directly from STi55xx ports to a 24-pin connector (item 1704). From the same connector, the HSYNC, VSYNC and 27MHZ\_CLK signals are available. The digital YUV connector is the interface to external video processing devices; such as high quality progressive scan codex and high quality video DAC.

##### Analogue video

The STi55xx is capable of 6-channel analogue video. Three channels (pins 25, 26 and 27) are RGB or YUV format, while the other three channels (pins 32, 33 and 34) are Y, C, and CVBS.

A video output buffer (see diagram M7, e.g. item 7701 for R) is implemented: an 8MHz/16MHz selectable filter stage and a 75Ω drive stage.

**Clock Factory**

One clock factory is implemented to support all clocks required by the Furore 2. The various master clock, which depends on whether SACD is present, is used for SD4.00\_SA\_CH. The clock factory of SD4.00\_SA\_CH is showed in Figure 8-2.

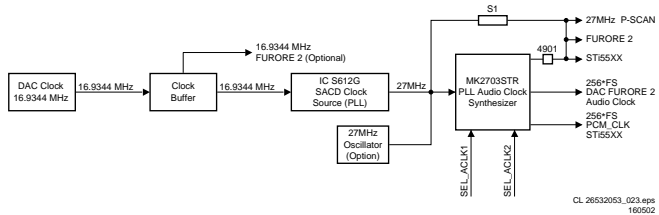

**Figure 9-7 Block diagram clock factory**

For the SACD player, the clock system is a DAC master clock system. For non-SACD player, the clock system is a mono board master clock system.

The Furore 2 supports clock 256\*FS/384\*FS/512\*FS. The most convenient value in the market is 16.9344 MHz (384\*FS, FS=44.1kHz). Therefore, the master clock on the SD4.00\_SA\_CH mono board is the 384\*FS coming from the A/V board. The 384\*FS (16.9344 MHz) from the DAC clock, must always be present. It is buffered before it is sent to the Furore 2 and the rest of the clock factory. The IC S612G delivers a 27 MHz system clock.

The Furore 2 and Sti5580/Sti5588 (Video) use this clock. It is used to derive the PCM audio clocks 256\*FS by the MK2703STR. This IC is also used to buffer the incoming 27 MHz clock.

The communication between the Sti55xx and the Furore 2 is asynchronous.

To support non-SACD playback, an on-board 27MHz oscillator delivers the master clock for SD4.00\_SA\_CH mono board.

**Miscellaneous**

Most general IO ports are connected directly to the module interface. Compared with the SD3.0 module, some on-board circuits are removed, as it made more sense (and more cost effective) to implement these circuits externally.

**SCART Status Signal**

The SCART0 and SCART1 signals are directly available at the module interface, where the 0\_6\_12V signal is generated. See table below:

**Table 9-1 0\_6\_12V SCART status truth table**

Function	PIO3_6 (SCART0)	PIO3_7 (SCART1)	0_6_12V (at SCART connector)
TV display	1	1	0V
TV display	0	1	0V
16:9 aspect ratio	1	0	+6V
4:3 aspect ratio	0	0	+12V

**Mute**

The audio MUTE signal (active 'high') is directly available at the module interface.

**Service**

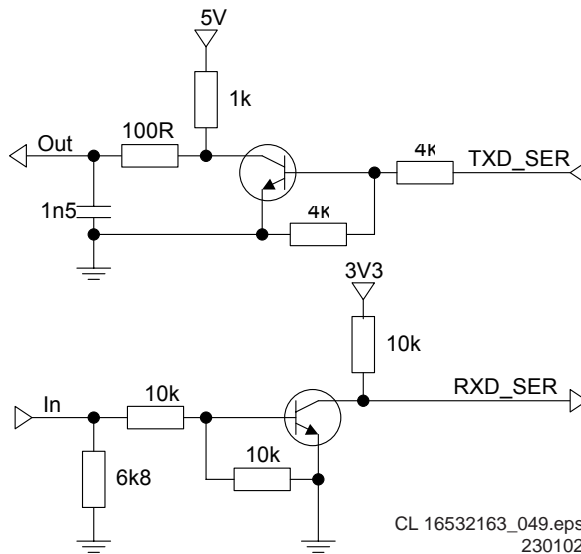
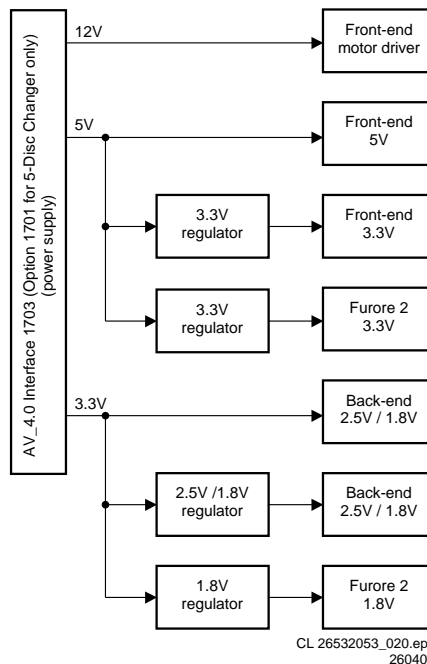

**Figure 9-8 Service Port Buffer**

The service port (see diagram M5) is simplified to reduce cost. The unused RTS and CTS lines are no longer connected. A transistor buffer (item 7502) is used instead of the Schmitt Trigger buffer (item 7501). The overall loading and driving capability of the RS-232 emulator port is not greatly changed. However, as a precaution, the Schmitt Trigger circuit remains in the layout as an optional implementation.

This SD4.0SA\_CH has the same ComPair connector as in previous DVD generations. Flashing of the application-SW is not possible with the ComPair cable, except with a CD-R disc. For sets with Mask-ROM software, replace it with a programmed Flash (available via your Philips Service organisation).

**Power Supply (diagram M7)**



**Figure 9-9 Mono Board Power Supply Block Diagram**

The main power supplies to the module are 3.3V, 5V, and 12V (input via connector 1703).

The SACD DSD/DST decoder Furore 2 uses 1.8V for its core and analogue portion, and 3.3V for its interface. The on-board 1.8V linear regulator LF18ABDT and 3.3V linear LD1117DT33 are used to generate 1.8V and 3.3V power supply respectively. The back-end section mainly uses the 1.8V or 2.5V and 3.3V, which depend on which back-end processor is used. The on-board linear regulators LF25ABDT or LF18ABDT are used to generate the 2.5V (or 1.8V) required by the STi55xx. The front-end section mainly uses the 5V and 12V. An on-board linear regulator LD1117DT33 can be used to generate the 3.3V required by the front-end. The 12V is used by the motor and servo drivers.

#### Reset Circuit

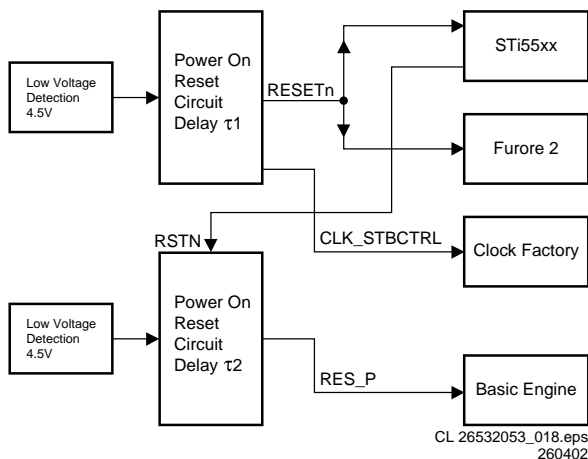

Figure 9-10 Block diagram of reset circuit

This reset circuit takes care that booting the different devices on the mono board takes place in the correct order. The correct reset order is:

1. The Power On Reset circuit (delay  $t_1$ ) creates a reset signal 'RESETn' to reset the STi55xx and Furore .
2. In the meantime, the Power On Reset circuit (delay  $t_1$ ) creates a reset signal 'CLK\_STBCTRL', which is inverted to 'RESETn', to enable the Clock Factory.
3. Then, the Power On Reset circuit (delay  $t_2$ ) generates a reset signal 'RES\_P' to reset the Basic Engine.
4. The STi55xx can now reset the Basic Engine via 'RSTN'.

## 9.4 Audio/Video (A/V) Board

This board is the interface panel between the DVD-player and its peripherals.

### 9.4.1 Block diagram

See Block diagram A/V Board in chapter 6.

### 9.4.2 Control

The control of the A/V board is done by I<sup>2</sup>C-decoder IC7107 (see table below):

Table 9-2 Control lines overview IC7107

Description	Pin	Hi	Lo
CLK_SEL	12	External clock (DSD stream)	Internal clock (PCM stream)
UPSAMPLING	11	No upsampling	Upsampling
DAC_RESET	10	Normal	Reset
CENTER_ON	9	Off	On
SPDIF-MUTE	5	Mute	No mute
192k/96k	4	192k PCM	96k PCM

### 9.4.3 Video

The analogue video signals from the Mono Board are buffered before they are fed to the A/V board. The video outputs from the A/V Board are RGB/YUV, YC, and CVBS. These signals are also fed to the double SCART board.

### 9.4.4 Audio

The digital audio signals for Surround, Centre and LFE (subwoofer) are fed to a 6-channel DAC CS4362 (item 7300, 48-pin LQFP) for the audio output. This DAC accepts both DSD and PCM data streams.

The digital audio signals for Front and Stereo are fed to a high performance current output DAC AD1955 (item 7301) via a multiplexer (item 7200) which selects either the direct PCM or an upsampled data stream (determined by the UPSAMPLING control line).

The Upsampling is only applicable for CD playback, and the AD1895 sample rate converter (item 7201) converts the 44.1 kHz/16 bit audio to various formats such as 96 kHz/24 bit or 192 kHz/24 bit.

The bit and word clock, required by the upsampling DAC AD1955 (item 7301), are derived from the 24.576 MHz master clock (item7103) via counter (item 7204/7205).

The S/PDIF, only supports digital output upsampling of 96 kHz/24 bit and is encoded by the digital audio transmitter AK4103 (item7203).

There is a control line from IC7107, called CENTRE\_ON, which is used to switch between the centre channel and front channels for both SACD- and DVD modes.

### 9.5 Progressive Scan Board

The DVD963SA series offer progressive scan YUV outputs, and the option to select the interlace YUV output by a sliding switch on the board (selectable at the rear of the player).

#### 9.5.1 Block diagram

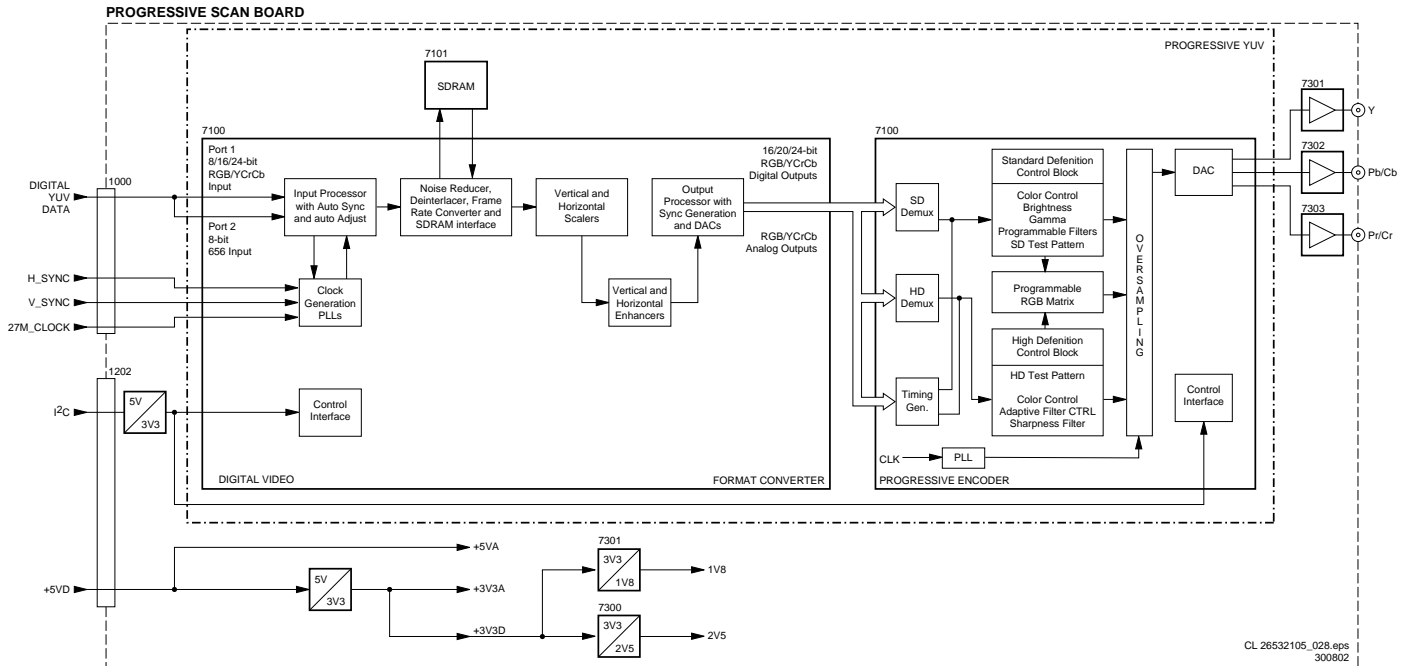

Figure 9-11 Block diagram Progressive Scan Board

#### 9.5.2 Progressive YUV

This creates a picture signal with double the scan lines of a conventional interlaced picture, to create a noticeably sharper and smoother image. It offers higher picture resolution and eliminates virtually all motion artefacts. Even on large screens, the progressive scan lines are barely noticeable and it reduces picture flickering significant.

Two new IC's are used: the Faroudja FLI2310 Digital Video Format Converter, and the Analog Devices ADV7300 Progressive Scan Video Encoder.

This board also offers the Digital Crystal Clear feature, which allow you to fine-tune the following parameters:

- Gamma correction.
- Chroma and Luma delay.
- Sharpness.
- DCDi: to produce a smooth and natural looking image without visible artifacts (like jagged edges).
- True life: brings out details in the picture, producing a more life-like image.

### 9.6 Double SCART

This board consists of two SCART connectors and a SCART-switch (item 7501, STV6410), which is controlled by I<sup>2</sup>C. In a P50 player with double SCART connectors, video and audio loop-through must be available. This loop-through is controlled by the P50 commands, which are send via pin 10 of the SCART connector. When the DVD player is in standby, the loop-through is active. During standby, the display (slave) processor is active (takes over the I<sup>2</sup>C-bus), and will manage the P50 commands.

**Note:** The loop-through only functions when the DVD-player is in standby (NOT in low power standby)

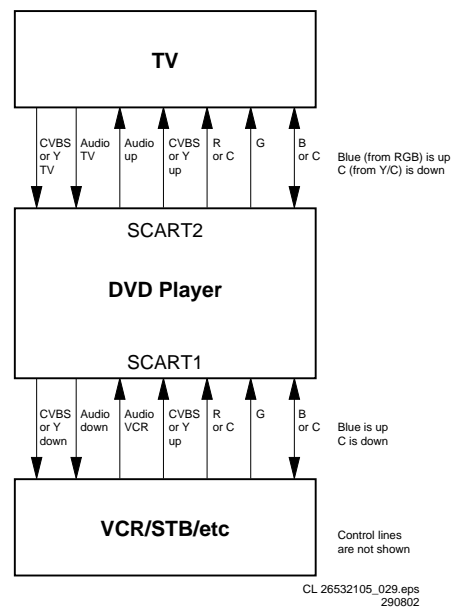

Figure 9-12 Loop-through set-up

The B component (from RGB) and the C component (from Y/ C) share the same pin on the SCART connector (pin 7). Because the B-signal is an "up-stream" signal (towards the TV) and the C-signal is a "down-stream" signal (towards the VCR), this pin 7 must be a bi-directional pin. Because the STV6410

does not support this, an external circuit (two bi-directional switches, named switch "1" and switch "2") is added. The Y- and CVBS-components also share the same pins.

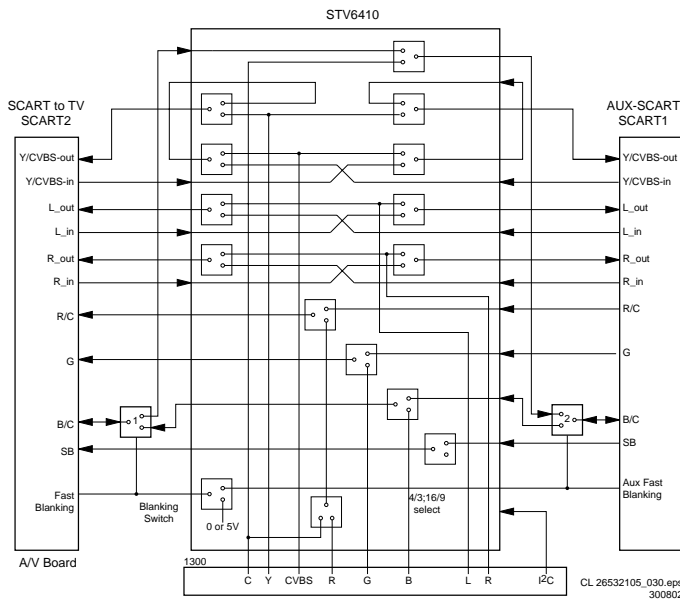

Figure 9-13 SCART switching circuitry

- Switch "1" is controlled by the FB (Fast Blanking) pin (pin 16) of SCART2 (TV SCART):
  - If the FB line is low, C is input on the B/C of SCART2.
  - If the FB line is high, B is output on the B/C of SCART2.
- Switch "2" is controlled by the FB (Fast Blanking) pin (pin 16) of SCART1 (AUX SCART):
  - If the FB line is low, C is output on the B/C of SCART1.
  - If the FB line is high, B is input on the B/C of SCART1.

We can distinguish four situations:

1. DVD player is ON, DVD is active (DVD mode): NO LOOP-TROUGH.
2. DVD player is ON, DVD is not active (TV mode): LOOP-TROUGH.
3. DVD player is ON, external source becomes active: LOOP-TROUGH.
4. DVD player is in STBY: LOOP-TROUGH.

## 9.7 Control and Display Panel

### 9.7.1 Control

#### Slave processor

The key component on this board is the (slave) microprocessor (item 7401). It runs on an 8 MHz system clock generated with a ceramic resonator (item 1119) and has a reset circuit (item 7105) that is triggered by the +5Vstb voltage.

The start-up sequence is as follows:

1. The required IC voltage is the +5Vstb, which is present during Standby Mode.
2. When the RESET circuit (item 7105) is triggered by the +5Vstb, the slave uP initialises.
3. This will set the STDBY\_CONTROL signal to LOW, which will switch on the 12V and subsequently the +3V3.
4. Once these voltages are provided, the host uP (on the mono board) will reset (via reset circuit around item 7412 on the mono board, diagram M4).
5. Now, the host uP will initialise, and indicate the slave uP to activate the Standby Mode (STBY\_CONTROL) signal.
6. The player wakes up from the Standby Mode when any button is pressed on the front panel, or when the 'Power' button is pressed on the Remote Control.

Also, when going to Standby, the slave processor will reset the host processor. When the slave processor receives the correct IR (or key) code to leave the Standby mode, it resets the host processor.

**Note:** The slave uP will not reset successfully, if the 8MHz clock oscillator has not stabilised (check on pin 8 of IC7101).

Other slave processor functions are:

- Generation of a scanning grid for the keys,
- Generation of the display grid and segment scanning,
- Generation of square signal to generate the filament voltage for FTD display,
- Inputs for RC5/6 and P50 (P50 controller is build in).

#### Standby LED

Transistor 7104 drives the Standby LED. When the STBLEDD signal from the slave processor is 'high' (pin 14), the LED is 'off'.

#### Key Matrix

When a key on the local keyboard is pressed, the signal at the scanning pins of the microprocessor (pins 34, 35, 36 and 37) go from +5 V to 0 V.

#### IR Receiver

The IR controller in the slave processor handles both RC5 and RC6 signals (input on pin 22). The logic is +5 V for 'high' and 0 V for 'low'.

#### Status LEDs

The four status LEDs (SOUND, AUDIO DIRECT, UP-SAMPLING, and P-SCAN) are controlled by the slave processor.

#### P50 Interface

P50 (or Easylink) is a bi-directional serial interface for communication between video equipment. For European sets, this communication goes via pin 10 of the SCART connector, while for other regions (when present), this is a cinch connector. The slave processor controls the P50 bus (via pins 11 and 20).

### 9.7.2 Display

Because these DVD players have an AC display (FTD) and a DC supply, an AC voltage is created by the microprocessor. The slave processor has an internal square signal generator (42 kHz, duty cycle 45/55), to generate the AC filament voltage. This square voltage is amplified (by TS7106 and 7109) and decoupled (C2138 and C2143) before it is applied to the display. The necessary voltage of -32 V comes directly from the PSU.

## 9.8 Abbreviation list

ADC	Analogue to Digital Converter	SRAM	Static RAM
AGC	Automatic Gain Control	STBY	Standby
ASD	Architecture and Standard Design	SVCD	Super Video CD
AM	Amplitude Modulation	SW	Software
BE	Basic Engine	THD	Total Harmonic Distortion
ComPair	Computer aided rePair	TTL	Transistor Transistor Logic (5V logic)
CD-DA	CD Digital Audio	uP	Microprocessor
CS	Chip Select	VAL	Video Audio Loader
CVBS	Composite Video Blanking and Synchronisation	VCD	Video CD
DAC	Digital to Analogue Converter	Y/C	Luminance (Y) and Chrominance (C) signal
DAIO	Digital Audio Input Output	YUV	Component video
DEMUX	De-multiplexer		
DENC	Digital Encoder		
DFU	Direction For Use: description for the end user		
DNR	Dynamic Noise Reduction		
DRAM	Dynamic Random Access Memory		
DSD	Direct Stream Digital		
DSP	Digital Signal Processing		
DST	Direct Stream Transfer (= loss less compressed DSD signal)		
DTS	Digital Theatre Sound		
DVD	Digital Versatile Disc		
EEPROM	Electrically Erasable and Programmable Read Only Memory		
EFM	Eight to Fourteen bit Modulation		
EMI	External Memory Interface (STi55xx)		
FFC	Flat Foil Cable		
FLASH	Flash memory		
HPF	High Pass Filter		
HW	Hardware		
I <sup>2</sup> C	Integrated IC bus (signals at 5V level)		
I <sup>2</sup> S	Integrated IC Sound bus (signals at 3.3V level)		
IC	Integrated Circuit		
IF	Intermediate Frequency		
IRQ	Interrupt Request		
KOK	Karaoke		
LFE	Low Frequency Effect (= subwoofer)		
LLD	Loss Less Decoder		
LPCM	Linear Pulse Code Modulation		
LRCLK	Left/Right clock		
LVTTL	Low Voltage Transistor Transistor Logic (3.3V logic)		
M2	Mercury 2 Basic Engine		
MACE	Mini All Compact Disc Engine		
MPEG	Motion Pictures Experts Group		
NC	Not Connected		
NVM	Non Volatile Memory (= IC containing TV related data e.g. alignments)		
OC	Open Circuit		
OPU	Optical Pick-up Unit		
PCB	Printed Circuit Board (see PWB)		
PCM	Pulse Code Modulation		
PCM_CLK	Audio system clock for DAC		
PCM_OUTx	Audio serial output data		
PSP	Pit Signal Processing		
PSU	Power Supply Unit		
PWB	Printed Wiring Board (see PCB)		
RAM	Random Access Memory		
RGB	Red, Green and Blue colour space		
ROM	Read Only Memory		
S2B	Serial to Basic Engine (= communication bus between host- and servo processor)		
SCL	Serial Clock I <sup>2</sup> C		
SCLK	Audio serial bit clock		
SDA	Serial Data I <sup>2</sup> C		
SDRAM	Synchronous DRAM		
SMI	Shared Memory Interface		
S/PDIF	Sony Philips Digital InterFace		

9.9 IC Data

In this paragraph, the internal block diagrams and pinning are given of ICs that are drawn as 'black box' in the electrical diagrams (with the exception of 'memory' and 'logic' ICs).

9.9.1 Diagram Power Supply: TY72011P2 (item 7130)

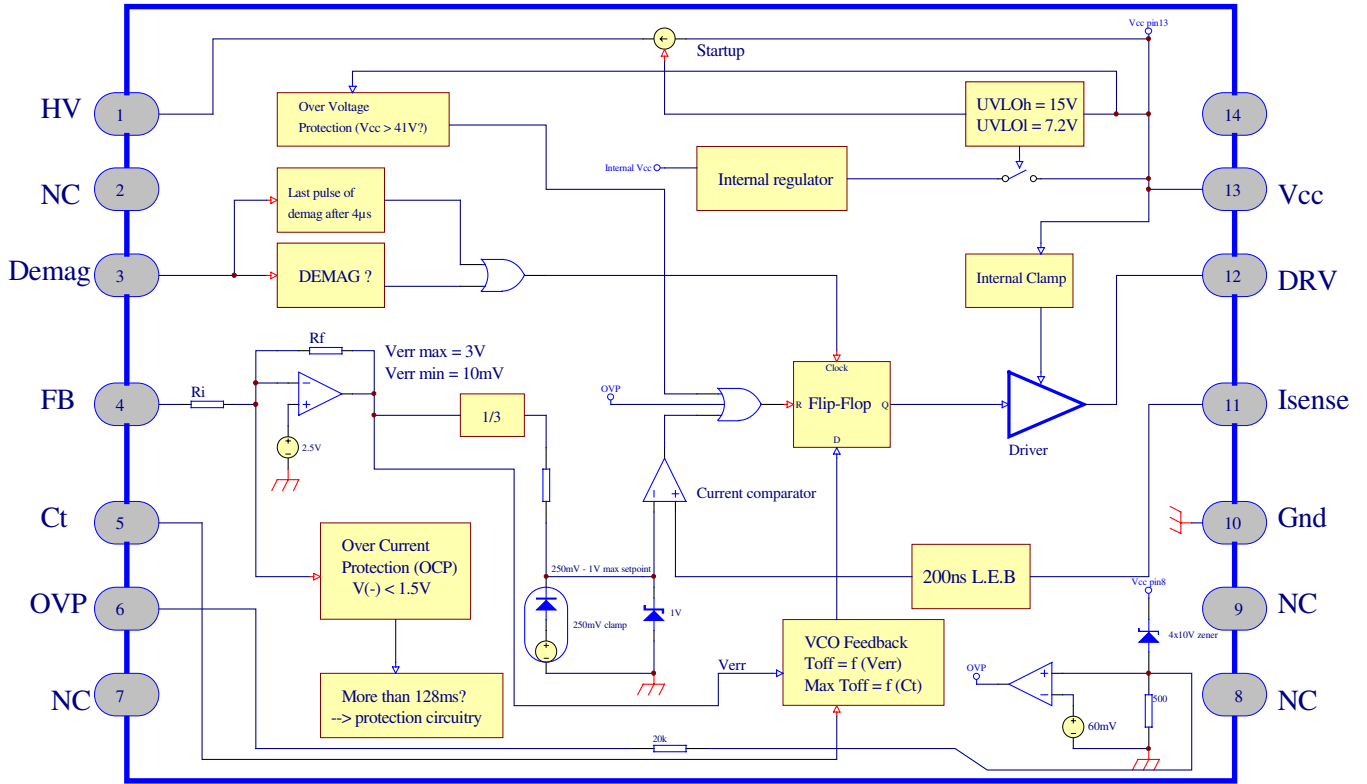
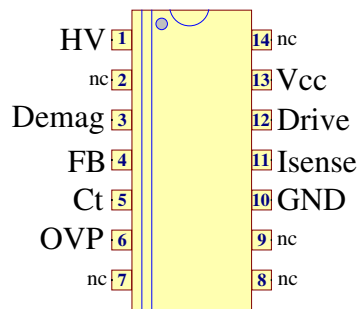

Figure 9-14 Block Diagram



PIN CONNECTIONS

Figure 9-15 Pinning

9.9.2 Diagram A2: AK4103VF (IC7203)

■ Block Diagram

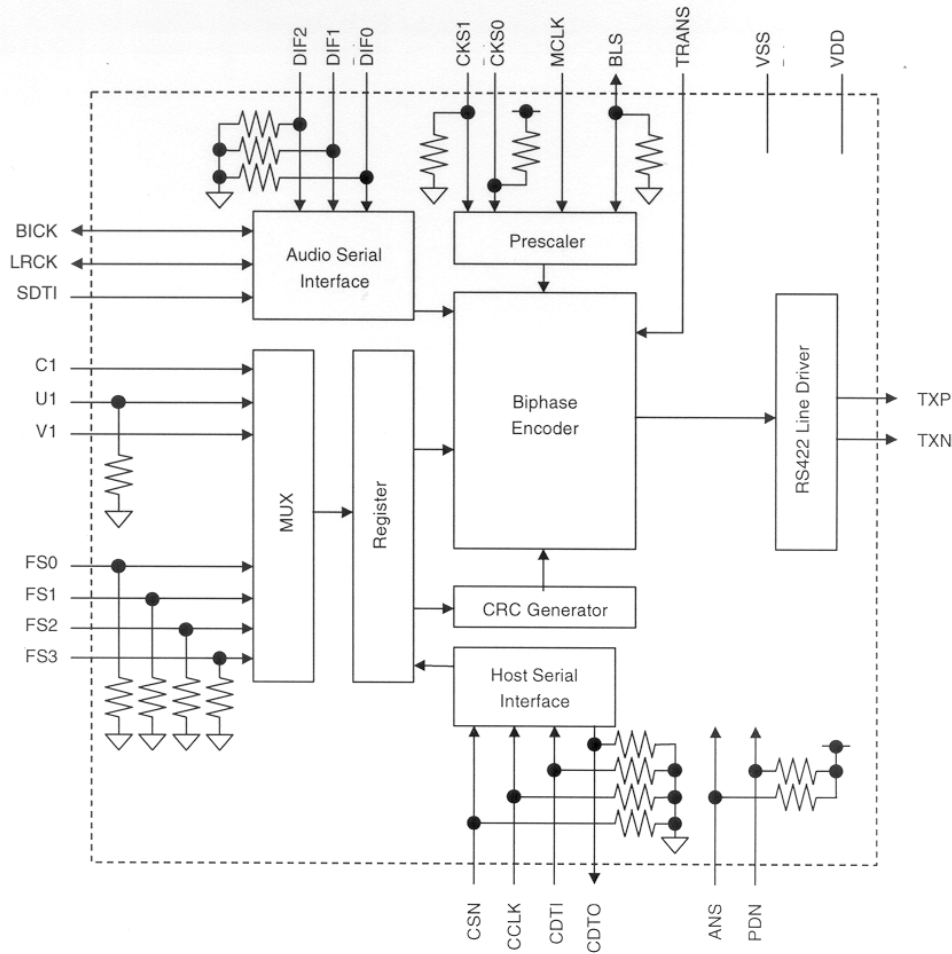

■ Pin Layout

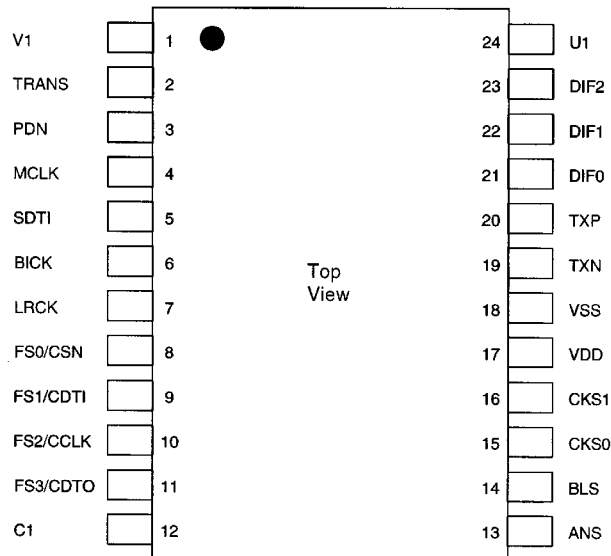

CL 26532105\_054.eps  
300802

Figure 9-16 AK4103VF (IC7203)



9.9.3 Diagram A3: CS4362 (IC7300)

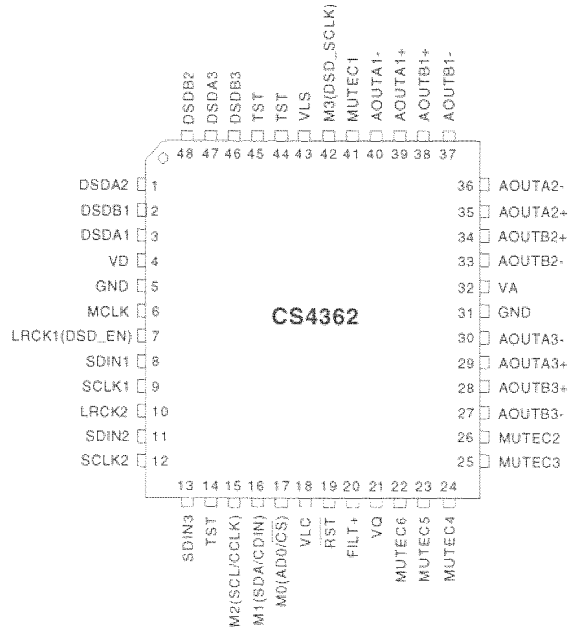
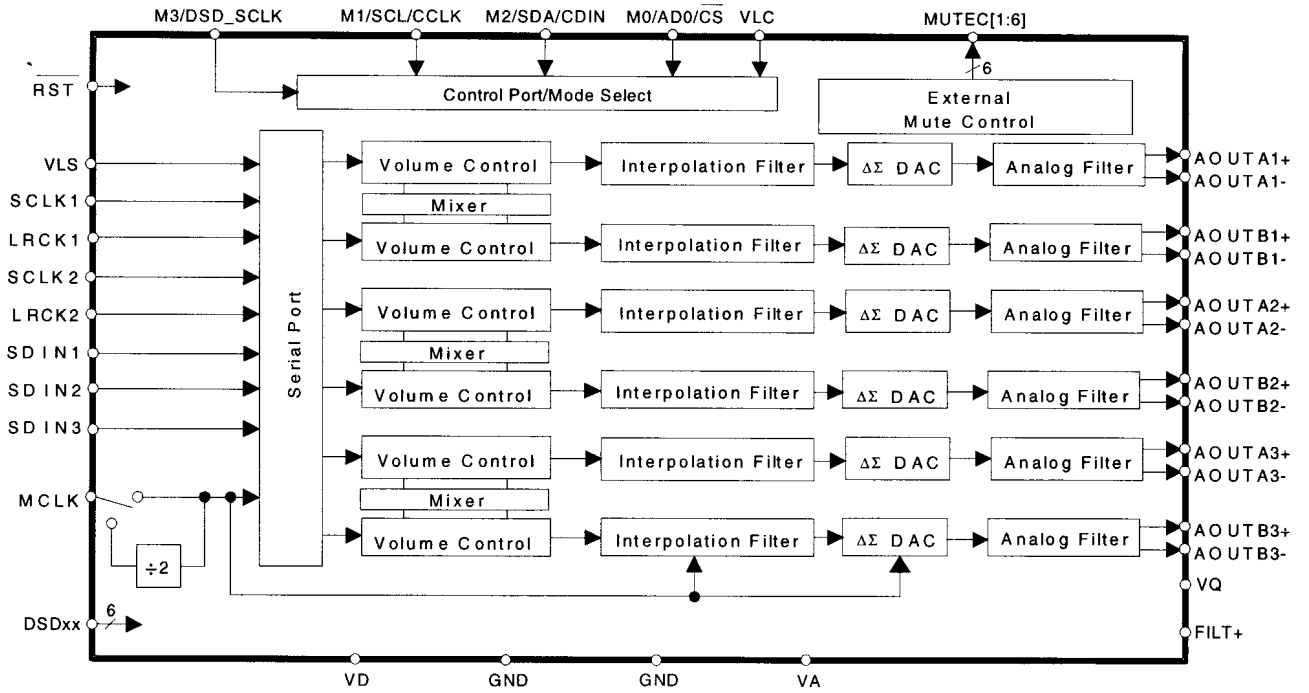

CL26532105\_055.eps  
300802

Figure 9-17 CS4362 (IC7300)

9.9.4 Diagram P1: FLI2301 (item 7100)

BLOCK DIAGRAM

Simplified Internal Block Diagram

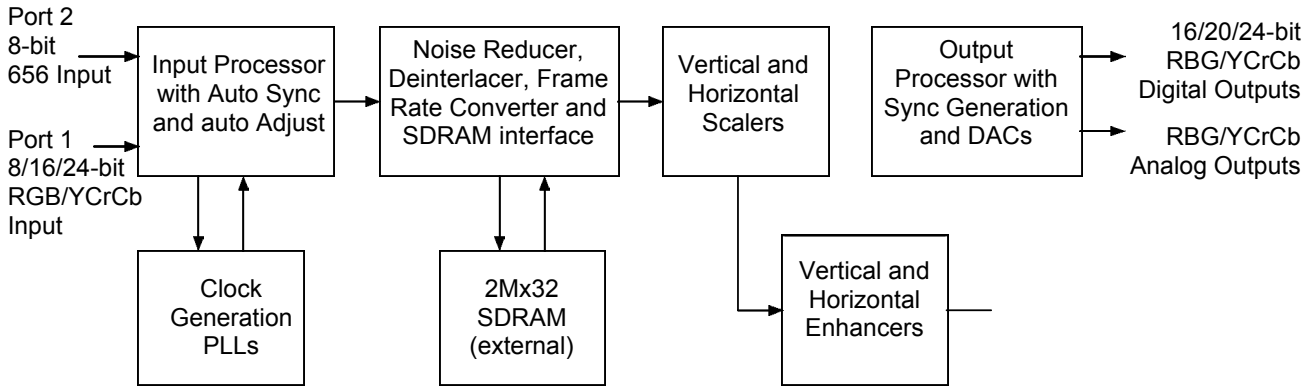

Pin Diagram

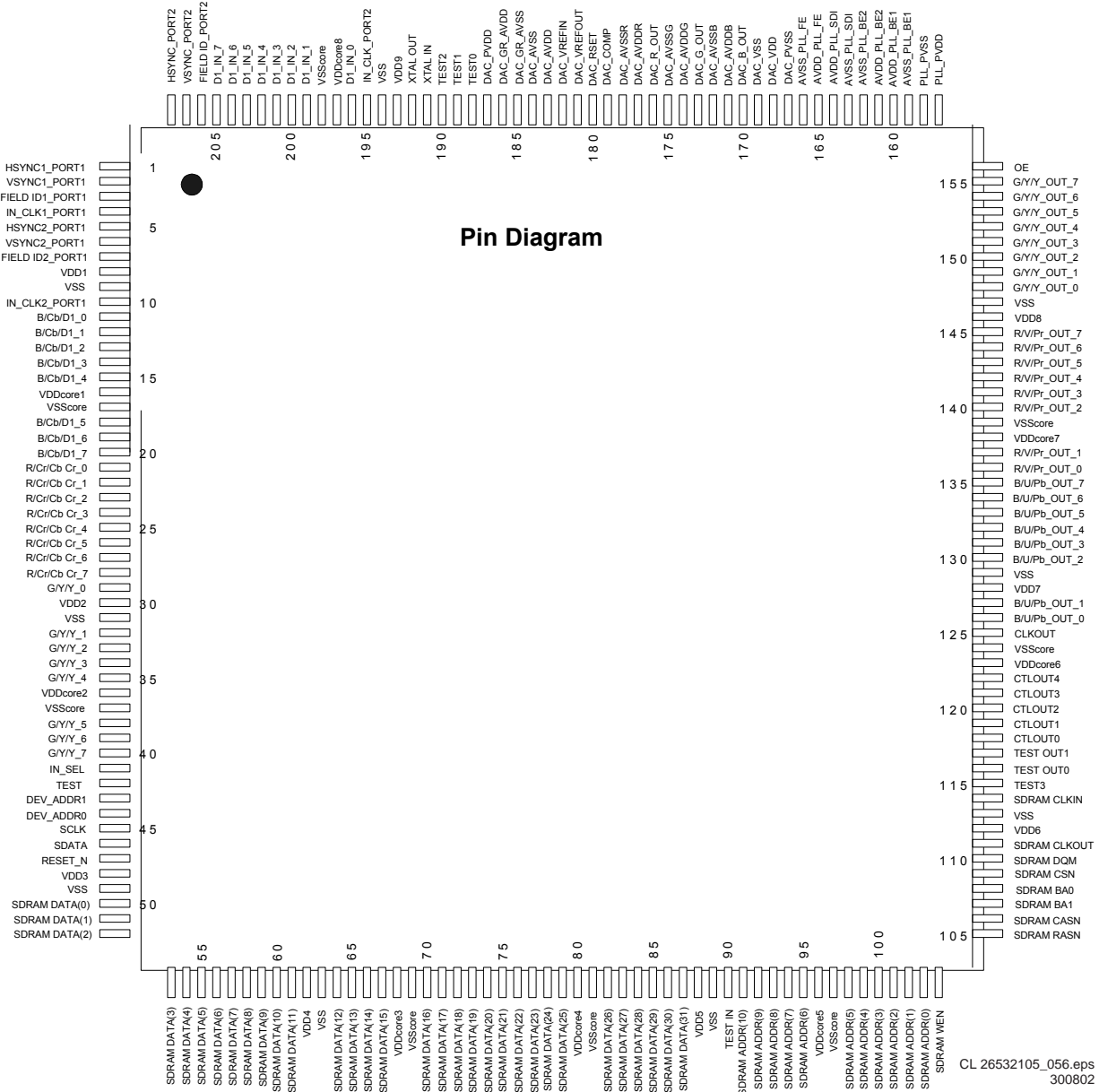

CL 265321105\_056.eps  
300802

Figure 9-18 FLI2301 (item 7100)

## 10. Spare Parts List

### Mechanical /001

#### Various

0002	3139 247 56601	FRONT ASSY DVD963SA/00X
0078	3139 243 10161	FILTER FTD SACD900
0150	3139 247 56581	BOTTOM FRAME ASSY DVD963SA/00X
0155	2422 030 00395	SOC POW H 3P M AC IEC B
0250	3139 247 56571	PLATE BACK DVD963SA/00X PPT
0300	3139 247 51691	COVER TOP DVD956K PNT PRT
0350	3139 238 02121	PROD. ASSY RC19237006/01H PKD
0360▲	2422 070 98224	MAINSCORD IEC 10A 1M5 DET BK B
0365	3103 308 92610	CABLE AUDIO 2X2RCA MALE 1.5MTR
0366	4822 321 61579	VIDEO-CABLE
0372	2422 076 00468	CBLE SCART 1M1 SCART 21P BK B
0375	3139 246 11991	IFU DVD963SA/00X
1010▲	3122 427 23261	PSU SUPER AUDIO CD WR HE
1103	3139 110 36071	FFC FOIL 30P/100/30P BD 1MMP
1104	3139 110 36071	FFC FOIL 30P/100/30P BD 1MMP
1108	3139 241 00191	FFC FOIL 24P/180/24P BD1MMP FD
1110	3139 241 00201	FFC FOIL 22P/220/22P BD 1MMP
0374	3139 246 12131	IFU2 DVD963SA/00X

### Mechanical /171

#### Various

0002	3139 247 56601	FRONT ASSY DVD963SA/00X
0078	3139 243 10161	FILTER FTD SACD900
0150	3139 247 56581	BOTTOM FRAME ASSY DVD963SA/00X
0155	2422 030 00395	SOC POW H 3P M AC IEC B
0250	3139 247 56561	PLATE BACK DVD963SA/17X PPT
0300	3139 247 51691	COVER TOP DVD956K PNT PRT
0350	3139 238 02121	PROD. ASSY RC19237006/01H PKD
0360▲	2422 070 98223	MAINSCORDUL 10A 1M5 DET BK B
0365	3103 308 92610	CABLE AUDIO 2X2RCA MALE 1.5MTR
0366	4822 321 61579	VIDEO-CABLE
0375	3139 246 11961	IFU DVD963SA/17X
1010▲	3122 427 23471	PSU SUPER AUDIO CD USA 35PS104
1103	3139 110 36071	FFC FOIL 30P/100/30P BD 1MMP
1104	3139 110 36071	FFC FOIL 30P/100/30P BD 1MMP
1108	3139 241 00191	FFC FOIL 24P/180/24P BD1MMP FD

### Mechanical /691

#### Various

0002	3139 247 56601	FRONT ASSY DVD963SA/00X
0078	3139 243 10161	FILTER FTD SACD900
0150	3139 247 56581	BOTTOM FRAME ASSY DVD963SA/00X
0155	2422 030 00395	SOC POW H 3P M AC IEC B
0250	3139 247 56561	PLATE BACK DVD963SA/17X PPT
0300	3139 247 51691	COVER TOP DVD956K PNT PRT
0350	3139 238 02121	PROD. ASSY RC19237006/01H PKD
0360▲	2422 070 98224	MAINSCORD IEC 10A 1M5 DET BK B

0365	3103 308 92610	CABLE AUDIO 2X2RCA MALE 1.5MTR
0366	4822 321 61579	VIDEO-CABLE
0375	3139 246 11951	IFU DVD963SA/69X
1010▲	3122 427 23261	PSU SUPER AUDIO CD WR HE
1103	3139 110 36071	FFC FOIL 30P/100/30P BD 1MMP
1104	3139 110 36071	FFC FOIL 30P/100/30P BD 1MMP
1108	3139 241 00191	FFC FOIL 24P/180/24P BD1MMP FD

### SD4.00SA Module

#### Various

0001	9305 023 61114	VAL6011/14
------	----------------	------------

### AV PWB

#### Various

1101	2422 543 01255	RES XTL SM 24MHz 576 30P AT-51R
1102	2422 543 01297	RES XTL SM 33M8688 16P NX6035R
1400	2422 025 17433	CON BM V 30P F 1.00 FFC 0.3 B
1401	2422 026 05345	SOE CINCH H 4P F YEWHYERD Y
1402	2422 026 05088	CON BM CINCH H 6P F B
1403	4822 265 11154	52030-2210 (22P)
1408	2422 026 05188	CON BM MDIN H 3P F TCS7927 B
1410	4822 267 31626	
1420	2422 025 10772	CON BM V 12P M 2.00 PH B
1421	2422 025 17433	CON BM V 30P F 1.00 FFC 0.3 B
1422	2422 025 17467	CON BM V 8P M 2.50 MIS B

—||—

2100	2238 586 59812	0603 50V 100NP80M
2101	4822 122 33761	22pF 5% 50V
2102	4822 126 11785	0603 50V 47P 5%
2103	4822 122 33752	15pF 5% 50V
2104	4822 122 33752	15pF 5% 50V
2105	4822 126 11663	12pF
2106	4822 126 11663	12pF
2107	4822 122 33752	15pF 5% 50V
2108	2238 586 59812	0603 50V 100NP80M
2110	2238 586 59812	0603 50V 100NP80M
2111	2238 586 59812	0603 50V 100NP80M
2112	2238 586 59812	0603 50V 100NP80M
2113	2238 586 59812	0603 50V 100NP80M
2114	2020 552 93645	0603 50V 39P 5%
2115	2020 552 93645	0603 50V 39P 5%
2116	4822 122 33761	22pF 5% 50V
2117	2238 586 59812	0603 50V 100NP80M
2118	4822 126 11663	12pF
2119	4822 126 11663	12pF
2200	2238 586 59812	0603 50V 100NP80M
2201	2238 586 59812	0603 50V 100NP80M
2202	2238 586 59812	0603 50V 100NP80M
2203	2238 586 59812	0603 50V 100NP80M
2204	2238 586 59812	0603 50V 100NP80M
2205	4822 124 40248	10µF 20% 63V
2206	4822 124 40248	10µF 20% 63V
2207	2238 586 59812	0603 50V 100NP80M
2208	2238 586 59812	0603 50V 100NP80M
2209	2238 586 59812	0603 50V 100NP80M
2210	4822 124 40248	10µF 20% 63V
2211	2238 586 59812	0603 50V 100NP80M
2212	4822 124 40248	10µF 20% 63V
2213	4822 124 40248	10µF 20% 63V
2230	2238 586 59812	0603 50V 100NP80M
2301	4822 124 40248	10µF 20% 63V
2302	4822 124 21913	1µF 20% 63V
2303	2238 586 59812	0603 50V 100NP80M
2304	2238 586 59812	0603 50V 100NP80M
2305	4822 124 21913	1µF 20% 63V
2306	2238 586 59812	0603 50V 100NP80M
2307	4822 124 40433	47µF 20% 25V
2308	2238 586 59812	0603 50V 100NP80M
2309	4822 124 21913	1µF 20% 63V

2310	2238 586 59812	0603 50V 100NP80M
2311	4822 124 41584	100µF 20% 10V
2312	4822 124 41584	100µF 20% 10V
2313	2238 586 59812	0603 50V 100NP80M
2314	4822 124 40433	47µF 20% 25V
2315	2238 586 59812	0603 50V 100NP80M
2316	2238 586 59812	0603 50V 100NP80M
2317	4822 124 40248	10µF 20% 63V
2318	2238 586 59812	0603 50V 100NP80M
2319	4822 124 21913	1µF 20% 63V
2321	2020 552 94427	0603 50V 100P 5%
2323	2020 552 94427	0603 50V 100P 5%
2400	2238 586 59812	0603 50V 100NP80M
2401	2238 586 59812	0603 50V 100NP80M
2402	2238 586 59812	0603 50V 100NP80M
2403	2238 586 59812	0603 50V 100NP80M
2404	2238 586 59812	0603 50V 100NP80M
2405	2238 586 59812	0603 50V 100NP80M
2406	2238 586 59812	0603 50V 100NP80M
2407	2238 586 59812	0603 50V 100NP80M
2408	2238 586 59812	0603 50V 100NP80M
2409	2238 586 59812	0603 50V 100NP80M
2410	2238 586 59812	0603 50V 100NP80M
2411	2238 586 59812	0603 50V 100NP80M
2412	4822 124 40207	100µF 20% 25V
2413	4822 124 40207	100µF 20% 25V
2414	2020 552 94427	0603 50V 100P 5%
2415	2020 552 94427	0603 50V 100P 5%
2416	2020 552 94427	0603 50V 100P 5%
2417	3198 016 36810	0603 25V 680P COL R
2418	4822 126 13881	470pF 5% 50V
2419	3198 016 36810	0603 25V 680P COL R
2420	4822 126 13881	470pF 5% 50V
2421	2020 012 93792	EL FG 16V S 100µF PM20 A
2422	2020 552 94427	0603 50V 100P 5%
2423	2020 552 94427	0603 50V 100P 5%
2424	2020 552 94427	0603 50V 100P 5%
2425	3198 016 36810	0603 25V 680P COL R
2426	4822 126 13881	470pF 5% 50V
2427	3198 016 36810	0603 25V 680P COL R
2428	4822 126 13881	470pF 5% 50V
2429	2020 012 93792	EL FG 16V S 100µF PM20 A
2431	3198 016 31020	0603 25V 1nF
2432	3198 016 31020	0603 25V 1nF
2434	3198 016 31020	0603 25V 1nF
2436	3198 016 31020	0603 25V 1nF
2437	3198 016 31020	0603 25V 1nF
2439	3198 016 31020	0603 25V 1nF
2440	3198 016 31020	0603 25V 1nF
2441	3198 016 31020	0603 25V 1nF
2442	4822 124 80195	470µF 20% 10V
2443	4822 124 80195	470µF 20% 10V
2444	4822 124 80195	470µF 20% 10V
2445	4822 124 80195	470µF 20% 10V
2500	2238 586 59812	0603 50V 100NP80M
2501	2238 586 59812	0603 50V 100NP80M
2502	2238 586 59812	0603 50V 100NP80M
2503	2238 586 59812	0603 50V 100NP80M
2510	4822 126 14506	270pF 5% 50V 0603
2511	4822 126 13881	470pF 5% 50V
2512	2020 552 94427	0603 50V 100P 5%
2513	2020 552 94427	0603 50V 100P 5%
2514	4822 126 13881	470pF 5% 50V
2515	4822 126 14506	270pF 5% 50V 0603
2516	4822 126 14506	270pF 5% 50V 0603
2517	2020 552 94427	0603 50V 100P 5%
2518	4822 126 13881	470pF 5% 50V
2519	4822 126 14506	270pF 5% 50V 0603
2520	2020 552 94427	0603 50V 100P 5%
2521	4822 126 13881	470pF 5% 50V
2522	4822 126 14506	270pF 5% 50V 0603
2523	4822 126 13881	470pF 5% 50V
2524	2020 552 94427	0603 50V 100P 5%
2525	2020 552 94427	0603 50V 100P 5%
2526	4822 126 13881	470pF 5% 50V
2527	4822 126 14506	270pF 5% 50V 0603
2528	4822 126 14506	270pF 5% 50V 0603
2529	4822 126 13881	470pF 5% 50V
2530	3198 016 31020	0603 25V 1nF
2531	3198 016 31020	0603 25V 1nF
2532	4822 124 40207	100µF 20% 25V
2533	2020 012 93792	EL FG 16V S 100µF PM20 A
2534	4822 124 40207	100µF 20% 25V
2535	2020 552 94427	0603 50V 100P 5%
2536	4822 124 40207	100µF 20% 25V
2537	2020 552 94427	0603 50V 100P 5%
2538	4822 126 13881	470pF 5% 50V
2539	4822 126 14506	270pF 5% 50V 0603
2540	3198 016 31020	0603 25V 1nF

2541	3198 016 31020	0603 25V 1nF	3305	5322 117 13018	1k0 1% 0.063W 0603 RC22H	3529	4822 117 12706	10k 1% 0.063W CASE0603 RC22H
2542	3198 016 31020	0603 25V 1nF	3306	4822 051 30759	75Ω 5% 0.062W	3530	5322 117 13022	22k 1% 0.063W 0603 RC22H
2543	3198 016 31020	0603 25V 1nF	3307	4822 051 30759	75Ω 5% 0.062W	3531	5322 117 13048	3k3 1% 0.063W 0603 RC22H
2544	3198 016 31020	0603 25V 1nF	3308	4822 051 30759	75Ω 5% 0.062W	3532	4822 117 12706	10k 1% 0.063W CASE0603 RC22H
2545	3198 016 31020	0603 25V 1nF	3310	4822 051 30103	10k 5% 0.062W	3533	4822 117 12706	10k 1% 0.063W CASE0603 RC22H
2546	4822 124 80875	220μF 20% 25V	3311	4822 051 30103	10k 5% 0.062W	3534	4822 117 12706	10k 1% 0.063W CASE0603 RC22H
2547	4822 124 80875	220μF 20% 25V	3313	4822 051 30103	10k 5% 0.062W	3535	5322 117 13022	22k 1% 0.063W 0603 RC22H
2600	4822 126 14494	22nF 10% 25V 0603	3314	4822 051 30103	10k 5% 0.062W	3536	5322 117 13048	3k3 1% 0.063W 0603 RC22H
2601	4822 126 13883	220pF 5% 50V	3400	4822 051 30103	10k 5% 0.062W	3537	4822 117 12706	10k 1% 0.063W CASE0603 RC22H
2602	4822 126 13883	220pF 5% 50V	3401	4822 051 30273	27k 5% 0.062W	3538	4822 117 12706	10k 1% 0.063W CASE0603 RC22H
2603	3198 017 44740	0603 10V 470nF COL	3403	5322 117 13049	470Ω 1% 0.063W 0603 RC22H	3539	4822 117 12706	10k 1% 0.063W CASE0603 RC22H
2604	4822 126 13883	220pF 5% 50V	3404	4822 051 30101	100Ω 5% 0.062W	3540	4822 051 30221	220Ω 5% 0.062W
2605	4822 126 13883	220pF 5% 50V	3405	5322 117 13061	180Ω 1% 0.063W 0603 RC22H	3541	4822 051 30102	1k 5% 0.062W
2606	4822 124 40433	47μF 20% 25V	3406	4822 051 30561	560Ω 5% 0.062W	3543	5322 117 13022	22k 1% 0.063W 0603 RC22H
2608	4822 124 40248	10μF 20% 63V	3408	4822 051 30101	100Ω 5% 0.062W	3544	5322 117 13048	3k3 1% 0.063W 0603 RC22H
2609	4822 124 40207	100μF 20% 25V	3409	5322 117 13049	470Ω 1% 0.063W 0603 RC22H	3545	4822 117 12706	10k 1% 0.063W CASE0603 RC22H
2610	4822 124 40433	47μF 20% 25V	3410	5322 117 13061	180Ω 1% 0.063W 0603 RC22H	3546	4822 117 12706	10k 1% 0.063W CASE0603 RC22H
2612	4822 124 40248	10μF 20% 63V	3411	5322 117 13052	2k7 1% 0.063W 0603 RC22H	3547	4822 117 12706	10k 1% 0.063W CASE0603 RC22H
2613	4822 124 80791	470μF 16V 20% 105C DXH=8X11.5	3412	5322 117 13046	1k8 1% 0.063W 0603 RC22H	3548	5322 117 13022	22k 1% 0.063W 0603 RC22H
2614	4822 124 40207	100μF 20% 25V	3413	5322 117 13052	2k7 1% 0.063W 0603 RC22H	3549	5322 117 13048	3k3 1% 0.063W 0603 RC22H
2616	4822 124 40207	100μF 20% 25V	3414	5322 117 13046	1k8 1% 0.063W 0603 RC22H	3550	4822 051 30221	220Ω 5% 0.062W
2617	2238 586 59812	0603 50V 100NP80M	3415	5322 117 13052	2k7 1% 0.063W 0603 RC22H	3551	4822 051 30102	1k 5% 0.062W
2618	4822 124 40248	10μF 20% 63V	3416	5322 117 13046	1k8 1% 0.063W 0603 RC22H	3552	4822 051 30103	10k 5% 0.062W
2619	4822 124 81144	1000μF 16V	3417	5322 117 13046	1k8 1% 0.063W 0603 RC22H	3553	4822 051 30103	10k 5% 0.062W
2620	4822 124 40248	10μF 20% 63V	3418	4822 051 30101	100Ω 5% 0.062W	3555	4822 051 30471	470Ω 5% 0.062W
2621	2238 586 59812	0603 50V 100NP80M	3419	5322 117 13052	2k7 1% 0.063W 0603 RC22H	3556	4822 051 30102	1k 5% 0.062W
2622	4822 126 11785	0603 50V 47P 5%	3421	5322 117 13049	470Ω 1% 0.063W 0603 RC22H	3558	4822 051 30471	470Ω 5% 0.062W
2623	4822 126 11785	0603 50V 47P 5%	3422	5322 117 13061	180Ω 1% 0.063W 0603 RC22H	3560	4822 051 30102	1k 5% 0.062W
2624	5322 126 11583	10nF 10% 50V 0603	3423	4822 051 30101	100Ω 5% 0.062W	3561	4822 051 30103	10k 5% 0.062W
2625	4822 124 40207	100μF 20% 25V	3424	4822 051 30561	560Ω 5% 0.062W	3562	4822 051 30103	10k 5% 0.062W
2626	4822 124 40207	100μF 20% 25V	3426	4822 051 30101	100Ω 5% 0.062W	3563	4822 051 30221	220Ω 5% 0.062W
2627	4822 124 80875	220μF 20% 25V	3427	5322 117 13049	470Ω 1% 0.063W 0603 RC22H	3564	4822 051 30102	1k 5% 0.062W
2628	4822 124 40433	47μF 20% 25V	3428	5322 117 13061	180Ω 1% 0.063W 0603 RC22H	3566	4822 051 30221	220Ω 5% 0.062W
2633	4822 124 40207	100μF 20% 25V	3429	5322 117 13052	2k7 1% 0.063W 0603 RC22H	3567	4822 051 30102	1k 5% 0.062W
2634	2238 586 59812	0603 50V 100NP80M	3430	5322 117 13046	1k8 1% 0.063W 0603 RC22H	3568	4822 051 30103	10k 5% 0.062W
2635	4822 124 40207	100μF 20% 25V	3431	5322 117 13052	2k7 1% 0.063W 0603 RC22H	3570	4822 051 30103	10k 5% 0.062W
2636	2238 586 59812	0603 50V 100NP80M	3432	5322 117 13046	1k8 1% 0.063W 0603 RC22H	3571	4822 051 30221	220Ω 5% 0.062W
2637	4822 124 40207	100μF 20% 25V	3433	5322 117 13046	1k8 1% 0.063W 0603 RC22H	3572	4822 051 30102	1k 5% 0.062W
2638	2238 586 59812	0603 50V 100NP80M	3434	5322 117 13046	1k8 1% 0.063W 0603 RC22H	3574	4822 051 30221	220Ω 5% 0.062W
2639	2238 586 59812	0603 50V 100NP80M	3435	5322 117 13046	1k8 1% 0.063W 0603 RC22H	3575	4822 051 30102	1k 5% 0.062W
2640	2238 586 59812	0603 50V 100NP80M	3436	4822 051 30101	100Ω 5% 0.062W	3576	4822 051 30103	10k 5% 0.062W
2646	4822 124 40433	47μF 20% 25V	3437	5322 117 13052	2k7 1% 0.063W 0603 RC22H	3577	4822 051 30103	10k 5% 0.062W
			3438	5322 117 13046	1k8 1% 0.063W 0603 RC22H	3579	4822 117 12925	47k 1% 0.063W 0603
			3439	5322 117 13046	1k8 1% 0.063W 0603 RC22H	3580	4822 051 30101	100Ω 5% 0.062W
			3440	5322 117 13046	1k8 1% 0.063W 0603 RC22H	3581	4822 051 30472	4k7 5% 0.062W
			3441	5322 117 13046	1k8 1% 0.063W 0603 RC22H	3582	4822 051 30103	10k 5% 0.062W
			3501	4822 051 30109	10Ω 5% 0.062W	3583	4822 051 30103	10k 5% 0.062W
			3502	4822 051 30109	10Ω 5% 0.062W	3584	4822 051 30103	10k 5% 0.062W
			3504	4822 051 30109	10Ω 5% 0.062W	3590	4822 051 30332	3k3 5% 0.062W
			3505	4822 051 30109	10Ω 5% 0.062W	3591	4822 117 12925	47k 1% 0.063W 0603
			3506	4822 117 12706	10k 1% 0.063W CASE0603 RC22H	3592	4822 117 12925	47k 1% 0.063W 0603
			3507	4822 117 12706	10k 1% 0.063W CASE0603 RC22H	3600	4822 051 30103	10k 5% 0.062W
			3508	5322 117 13022	22k 1% 0.063W 0603 RC22H	3601	4822 051 30332	3k3 5% 0.062W
			3510	4822 117 12706	10k 1% 0.063W CASE0603 RC22H	3602	4822 051 30223	22k 5% 0.062W
			3511	5322 117 13048	3k3 1% 0.063W 0603 RC22H	3603	4822 051 30222	2k2 5% 0.062W
			3512	4822 117 12706	10k 1% 0.063W CASE0603 RC22H	3604	4822 051 30101	100Ω 5% 0.062W
			3513	4822 117 12706	10k 1% 0.063W CASE0603 RC22H	3605	4822 051 30101	100Ω 5% 0.062W
			3514	4822 117 12706	10k 1% 0.063W CASE0603 RC22H	3606	4822 051 30101	100Ω 5% 0.062W
			3515	5322 117 13048	3k3 1% 0.063W 0603 RC22H	3607	4822 051 30101	100Ω 5% 0.062W
			3516	5322 117 13022	22k 1% 0.063W 0603 RC22H	3608	4822 051 30101	100Ω 5% 0.062W
			3517	4822 117 12706	10k 1% 0.063W CASE0603 RC22H	3609	4822 051 30101	100Ω 5% 0.062W
			3518	4822 117 12706	10k 1% 0.063W CASE0603 RC22H	3610	4822 051 30103	10k 5% 0.062W
			3519	4822 117 12706	10k 1% 0.063W CASE0603 RC22H	3611	4822 051 30183	18k 5% 0.062W
			3520	5322 117 13022	22k 1% 0.063W 0603 RC22H	3612	4822 051 30223	22k 5% 0.062W
			3521	5322 117 13048	3k3 1% 0.063W 0603 RC22H	3614	4822 051 30569	56Ω 5% 0.062W
			3522	4822 117 12706	10k 1% 0.063W CASE0603 RC22H	3615	4822 051 30569	56Ω 5% 0.062W
			3523	4822 117 12706	10k 1% 0.063W CASE0603 RC22H	3616	4822 051 30689	68Ω 5% 0.063W 0603 RC21 RST SM
			3524	4822 117 12706	10k 1% 0.063W CASE0603 RC22H	3617	4822 051 30689	68Ω 5% 0.063W 0603 RC21 RST SM
			3525	5322 117 13022	22k 1% 0.063W 0603 RC22H	3618	4822 051 30569	56Ω 5% 0.063W
			3526	5322 117 13048	3k3 1% 0.063W 0603 RC22H	3619	4822 051 30471	470Ω 5% 0.062W
			3527	4822 117 12706	10k 1% 0.063W CASE0603 RC22H	3620	4822 051 30221	220Ω 5% 0.062W
			3528	4822 117 12706	10k 1% 0.063W CASE0603 RC22H	3621	4822 051 30153	15k 5% 0.062W
						3622	4822 051 30222	2k2 5% 0.062W
						3623	4822 051 30759	75Ω 5% 0.062W
						3624	4822 051 30222	2k2 5% 0.062W
						3625	4822 051 30759	75Ω 5% 0.062W
						3626	4822 051 30222	2k2 5% 0.062W
						3627	4822 051 30759	75Ω 5% 0.062W
						3628	4822 051 30222	2k2 5% 0.062W
						3629	4822 051 30759	75Ω 5% 0.062W
						3630	4822 051 30222	2k2 5% 0.062W
						3631	4822 051 30759	75Ω 5% 0.062W

-W-

3100	4822 051 30101	100Ω 5% 0.062W
3101	4822 051 30101	100Ω 5% 0.062W
3102	4822 051 30101	100Ω 5% 0.062W
3103	4822 051 30101	100Ω 5% 0.062W
3104	4822 051 30101	100Ω 5% 0.062W
3105	4822 051 30101	100Ω 5% 0.062W
3106	4822 051 30101	100Ω 5% 0.062W
3107	4822 051 30101	100Ω 5% 0.062W
3108	4822 051 30101	100Ω 5% 0.062W
3109	4822 051 30472	4k7 5% 0.062W
3110	4822 051 30109	10Ω 5% 0.062W
3111	4822 051 30105	1M 5% 0.062W
3112	4822 051 30221	220Ω 5% 0.062W
3113	4822 051 30472	4k7 5% 0.062W
3114	4822 051 30472	4k7 5% 0.062W
3115	4822 051 30472	4k7 5% 0.062W
3116	4822 051 30472	4k7 5% 0.062W
3117	4822 051 30472	4k7 5% 0.062W
3118	4822 051 30472	4k7 5% 0.062W
3119	4822 051 30472	4k7 5% 0.062W
3120	4822 051 30479	47Ω 5% 0.062W
3123	4822 051 30479	47Ω 5% 0.062W
3124	4822 051 30332	3k3 5% 0.062W
3125	4822 051 30332	3k3 5% 0.062W
3126	4822 051 30332	3k3 5% 0.062W
3127	4822 051 30332	3k3 5% 0.062W
3128	4822 051 30479	47Ω 5% 0.062W
3129	4	



6107	9322 185 23676	LED VS LTL1CHTDK3 (LITO) A
6200	9322 190 53676	LED VS LTL42HCWK5P (LITO) A
		
7100	5322 130 60159	BC846B
7101	5322 130 60159	BC846B
7102	5322 130 60159	BC846B
7103	5322 130 60159	BC846B
7104	4822 130 60373	BC856B
7105	5322 130 60159	BC846B
7106	4822 130 40981	BC337-25
7108	5322 130 60159	BC846B
7109	4822 130 40854	BC327
7111	4822 130 60373	BC856B
7112	4822 130 60373	BC856B
7113	4822 130 60373	BC856B
7114	4822 130 60373	BC856B
7401	3139 240 50221	TMP87CH74F-3NB2 DVDV2.21
7402	9322 155 82667	IR RECEIVER TSOP2236

## P Scan PWB

## Various

1000	2422 025 17599	CON BM H 24P F 1.00 FFC 0.3 R
1003	2422 026 05191	CON BM CINCH H 3P F RDBUGN B
1203	2422 127 00548	SWI SLID 1P 2POS SM SSSS21 R

—|—

2100	4822 124 81286	47μF 20% 16V
2101	2238 586 59812	0603 50V 100NP80M
2102	3198 017 44740	0603 10V 470nF COL
2103	4822 124 81286	47μF 20% 16V
2105	2238 586 59812	0603 50V 100NP80M
2106	2238 586 59812	0603 50V 100NP80M
2107	4822 124 81286	47μF 20% 16V
2108	4822 124 11947	10μF 20% 16V
2109	2238 586 59812	0603 50V 100NP80M
2110	2238 586 59812	0603 50V 100NP80M
2111	2238 586 59812	0603 50V 100NP80M
2112	2238 586 59812	0603 50V 100NP80M
2113	2238 586 59812	0603 50V 100NP80M
2114	2238 586 59812	0603 50V 100NP80M
2115	2238 586 59812	0603 50V 100NP80M
2116	2238 586 59812	0603 50V 100NP80M
2117	2238 586 59812	0603 50V 100NP80M
2118	2238 586 59812	0603 50V 100NP80M
2119	2238 586 59812	0603 50V 100NP80M
2120	2238 586 59812	0603 50V 100NP80M
2121	2238 586 59812	0603 50V 100NP80M
2122	2238 586 59812	0603 50V 100NP80M
2123	2238 586 59812	0603 50V 100NP80M
2124	2238 586 59812	0603 50V 100NP80M
2125	2238 586 59812	0603 50V 100NP80M
2126	2238 586 59812	0603 50V 100NP80M
2127	2238 586 59812	0603 50V 100NP80M
2128	2238 586 59812	0603 50V 100NP80M
2129	2238 586 59812	0603 50V 100NP80M
2130	4822 126 13879	220nF 20% 16V
2131	4822 126 13879	220nF 20% 16V
2132	4822 126 13879	220nF 20% 16V
2133	4822 126 13879	220nF 20% 16V
2134	2238 586 59812	0603 50V 100NP80M
2135	2238 586 59812	0603 50V 100NP80M
2136	2238 586 59812	0603 50V 100NP80M
2137	2238 586 59812	0603 50V 100NP80M
2138	2238 586 59812	0603 50V 100NP80M
2139	2238 586 59812	0603 50V 100NP80M
2140	4822 126 13879	220nF 20% 16V
2141	4822 126 13879	220nF 20% 16V
2142	4822 126 13879	220nF 20% 16V
2143	4822 126 13879	220nF 20% 16V
2144	4822 126 13879	220nF 20% 16V
2145	4822 126 13879	220nF 20% 16V
2146	4822 126 13879	220nF 20% 16V
2147	4822 126 13879	220nF 20% 16V
2148	2238 586 59812	0603 50V 100NP80M
2149	2238 586 59812	0603 50V 100NP80M
2150	4822 122 33741	10pF 10% 50V
2209	2238 586 59812	0603 50V 100NP80M
2210	2238 586 59812	0603 50V 100NP80M
2211	2238 586 59812	0603 50V 100NP80M
2212	2238 586 59812	0603 50V 100NP80M

2213	2238 586 59812	0603 50V 100NP80M
2214	2238 586 59812	0603 50V 100NP80M
2215	2238 586 59812	0603 50V 100NP80M
2216	2238 586 59812	0603 50V 100NP80M
2217	2238 586 59812	0603 50V 100NP80M
2218	2238 586 59812	0603 50V 100NP80M
2220	2238 586 59812	0603 50V 100NP80M
2221	5322 126 11579	3.3nF 10% 63V
2222	3198 016 38210	0603 25V 820P COL
2223	4822 124 40769	4.7μF 20% 100V
2300	2238 586 59812	0603 50V 100NP80M
2301	4822 122 33761	22pF 5% 50V
2302	4822 126 11785	0603 50V 47P 5%
2304	4822 124 40184	1000μF 20% 10V
2305	2238 586 59812	0603 50V 100NP80M
2306	2238 586 59812	0603 50V 100NP80M
2307	3198 017 44740	0603 10V 470nF COL
2308	4822 124 81286	47μF 20% 16V
2309	2238 586 59812	0603 50V 100NP80M
2310	4822 122 33761	22pF 5% 50V
2311	4822 126 11785	0603 50V 47P 5%
2313	2238 586 59812	0603 50V 100NP80M
2314	4822 124 40184	1000μF 20% 10V
2315	4822 124 81286	47μF 20% 16V
2316	2238 586 59812	0603 50V 100NP80M
2317	4822 122 33761	22pF 5% 50V
2318	4822 126 11785	0603 50V 47P 5%
2320	4822 124 81286	47μF 20% 16V
2321	4822 124 81286	47μF 20% 16V
2322	4822 124 81286	47μF 20% 16V
2323	4822 124 81286	47μF 20% 16V

—W—

3100	4822 051 30109	10Ω 5% 0.062W
3101	4822 051 30151	150Ω 5% 0.062W
3102	4822 117 12139	22Ω 5% 0.062W
3103	4822 117 12139	22Ω 5% 0.062W
3104	4822 117 12139	22Ω 5% 0.062W
3107	4822 051 30101	100Ω 5% 0.062W
3108	4822 051 30101	100Ω 5% 0.062W
3109	4822 117 12139	22Ω 5% 0.062W
3110	4822 117 12139	22Ω 5% 0.062W
3111	4822 117 12139	22Ω 5% 0.062W
3112	4822 117 12139	22Ω 5% 0.062W
3113	4822 117 12139	22Ω 5% 0.062W
3114	4822 117 12139	22Ω 5% 0.062W
3115	4822 117 12139	22Ω 5% 0.062W
3116	4822 117 12139	22Ω 5% 0.062W
3117	4822 117 12139	22Ω 5% 0.062W
3118	4822 117 12139	22Ω 5% 0.062W
3119	4822 117 12139	22Ω 5% 0.062W
3120	4822 117 12139	22Ω 5% 0.062W
3121	4822 117 12139	22Ω 5% 0.062W
3122	4822 117 12139	22Ω 5% 0.062W
3123	4822 117 12139	22Ω 5% 0.062W
3124	4822 117 12139	22Ω 5% 0.062W
3125	4822 117 12139	22Ω 5% 0.062W
3126	4822 117 12139	22Ω 5% 0.062W
3127	4822 117 12139	22Ω 5% 0.062W
3128	4822 117 12139	22Ω 5% 0.062W
3129	4822 117 12139	22Ω 5% 0.062W
3130	4822 117 12139	22Ω 5% 0.062W
3131	4822 117 12139	22Ω 5% 0.062W
3132	4822 117 12139	22Ω 5% 0.062W
3133	4822 117 12139	22Ω 5% 0.062W
3134	4822 117 12139	22Ω 5% 0.062W
3135	4822 117 12139	22Ω 5% 0.062W
3136	4822 117 12139	22Ω 5% 0.062W
3137	4822 117 12139	22Ω 5% 0.062W
3138	4822 117 12139	22Ω 5% 0.062W
3139	4822 117 12139	22Ω 5% 0.062W
3140	4822 117 12139	22Ω 5% 0.062W
3141	4822 117 12139	22Ω 5% 0.062W
3142	4822 117 12139	22Ω 5% 0.062W
3143	4822 117 12139	22Ω 5% 0.062W
3144	4822 117 12139	22Ω 5% 0.062W
3145	4822 117 12139	22Ω 5% 0.062W
3146	4822 117 12139	22Ω 5% 0.062W
3147	4822 117 12139	22Ω 5% 0.062W
3148	4822 117 12139	22Ω 5% 0.062W
3149	4822 117 12139	22Ω 5% 0.062W
3150	4822 051 30472	4k7 5% 0.062W
3151	4822 117 12139	22Ω 5% 0.062W
3152	4822 117 12139	22Ω 5% 0.062W
3153	4822 117 12139	22Ω 5% 0.062W
3154	4822 117 12139	22Ω 5% 0.062W
3155	4822 117 12139	22Ω 5% 0.062W
3156	4822 117 12139	22Ω 5% 0.062W
3157	4822 117 12139	22Ω 5% 0.062W
3158	4822 117 12139	22Ω 5% 0.062W
3159	4822 117 12139	22Ω 5% 0.062W
3160	4822 117 12139	22Ω 5% 0.062W

3161	4822 117 12139	22Ω 5% 0.062W
3162	4822 117 12139	22Ω 5% 0.062W
3163	4822 117 12139	22Ω 5% 0.062W
3164	4822 117 12139	22Ω 5% 0.062W
3165	4822 117 12139	22Ω 5% 0.062W
3166	4822 117 12139	22Ω 5% 0.062W
3170	4822 051 30008	0Ω jumper
3172	4822 051 30008	0Ω jumper
3173	4822 117 12139	22Ω 5% 0.062W
3174	4822 117 12139	22Ω 5% 0.062W
3175	4822 117 12139	22Ω 5% 0.062W
3176	4822 117 12139	22Ω 5% 0.062W
3177	4822 117 12139	22Ω 5% 0.062W
3178	4822 117 12139	22Ω 5% 0.062W
3179	4822 117 12139	22Ω 5% 0.062W
3180	4822 117 12139	22Ω 5% 0.062W
3181	4822 117 12139	22Ω 5% 0.062W
3182	4822 117 12139	22Ω 5% 0.062W
3183	4822 117 12139	22Ω 5% 0.062W
3201	4822 051 30472	4k7 5% 0.062W
3203	4822 051 30152	1k5 5% 0.062W
3204	4822 117 12139	22Ω 5% 0.062W
3205	4822 051 30152	1k5 5% 0.062W
3206	4822 117 12139	22Ω 5% 0.062W
3207	4822 051 30472	4k7 5% 0.062W
3208	4822 051 30472	4k7 5% 0.062W
3209	4822 051 30101	100Ω 5% 0.062W
3210	4822 051 30103	10k 5% 0.062W
3211	4822 051 30101	100Ω 5% 0.062W
3212	4822 051 30103	10k 5% 0.062W
3213	4822 051 30101	100Ω 5% 0.062W
3214	4822 051 30101	100Ω 5% 0.062W
3215	4822 051 30472	4k7 5% 0.062W
3216	4822 051 30681	680Ω 5% 0.062W
3300	4822 051 30759	75Ω 5% 0.062W
3302	2322 704 63001	300R 1% 0.063W 0603
3303	2322 704 63001	300R 1% 0.063W 0603
3305	4822 051 30102	1k 5% 0.062W
3306	2322 704 63002	3k 1% 0.063W 0603
3307	4822 051 30759	75Ω 5% 0.062W
3309	2322 704 63001	300R 1% 0.063W 0603
3310	2322 704 63001	300R 1% 0.063W 0603
3312	4822 051 30102	1k 5% 0.062W
3313	2322 704 63002	3k 1% 0.063W 0603
3314	4822 117 11152	4Ω 7 5%
3316	2322 704 63001	300R 1% 0.063W 0603

## SCART PWB

## Various

1000	2422 025 12352	CON BM EURO H 21P F BK GRND-L
1001	2422 025 12352	CON BM EURO H 21P F BK GRND-L
1300	2422 025 16526	CON BM V 22P F 1.00 FFC 0.3 R

-II-

2100	4822 124 11947	10µF 20% 16V
2101	4822 124 40207	100µF 20% 25V
2102	4822 126 14305	100nF 10% 16V 0603
2103	4822 126 14305	100nF 10% 16V 0603
2104	4822 126 14305	100nF 10% 16V 0603
2105	4822 122 33777	47pF 5% 63V
2106	4822 122 33777	47pF 5% 63V
2107	4822 126 14305	100nF 10% 16V 0603
2108	4822 126 14305	100nF 10% 16V 0603
2109	4822 126 14305	100nF 10% 16V 0603
2110	4822 124 41584	100µF 20% 10V
2111	4822 126 14494	22nF 10% 25V 0603
2112	4822 126 14305	100nF 10% 16V 0603
2113	4822 126 14305	100nF 10% 16V 0603
2114	3198 017 44740	0603 10V 470nF COL
2115	3198 017 44740	0603 10V 470nF COL
2116	3198 017 44740	0603 10V 470nF COL
2117	4822 124 11947	10µF 20% 16V
2118	4822 124 11947	10µF 20% 16V
2119	4822 124 21732	10µF 20% 25V
2120	3198 017 44740	0603 10V 470nF COL
2121	4822 124 40207	100µF 20% 25V
2122	4822 126 14305	100nF 10% 16V 0603
2200	4822 124 12032	4.7µF 20% 50V
2201	4822 126 13883	220pF 5% 50V
2202	4822 124 12032	4.7µF 20% 50V
2203	4822 124 12032	4.7µF 20% 50V
2204	4822 124 12032	4.7µF 20% 50V
2205	4822 122 31765	100pF 2% 63V 1206
2206	4822 126 13883	220pF 5% 50V
2207	4822 126 13883	220pF 5% 50V
2208	4822 126 13883	220pF 5% 50V
2209	4822 126 13883	220pF 5% 50V
2210	4822 126 13883	220pF 5% 50V
2211	4822 124 21732	10µF 20% 25V
2212	4822 124 12032	4.7µF 20% 50V
2213	4822 124 12032	4.7µF 20% 50V
2214	4822 124 12032	4.7µF 20% 50V
2215	4822 124 12032	4.7µF 20% 50V
2216	4822 126 13883	220pF 5% 50V
2217	4822 126 13883	220pF 5% 50V
2218	4822 122 31765	100pF 2% 63V 1206
2219	4822 124 11947	10µF 20% 16V
2220	4822 126 13883	220pF 5% 50V
2221	4822 124 11947	10µF 20% 16V
2222	4822 126 13883	220pF 5% 50V
2223	4822 126 13883	220pF 5% 50V
2224	4822 126 13883	220pF 5% 50V
2225	4822 124 21732	10µF 20% 25V
2226	4822 126 13883	220pF 5% 50V

-WW-

3100	4822 117 11152	4Ω 7 5%
3102	4822 051 30103	10k 5% 0.062W
3104	4822 051 30472	4k7 5% 0.062W
3105	4822 051 30103	10k 5% 0.062W
3106	4822 051 30103	10k 5% 0.062W
3107	4822 051 30101	100Ω 5% 0.062W
3108	4822 051 30101	100Ω 5% 0.062W
3109	4822 051 30472	4k7 5% 0.062W
3110	4822 051 30103	10k 5% 0.062W
3111	4822 051 30102	1k 5% 0.062W
3112	4822 051 30472	4k7 5% 0.062W
3113	4822 051 30103	10k 5% 0.062W
3114	4822 051 30471	470Ω 5% 0.062W
3115	4822 051 30471	470Ω 5% 0.062W
3116	4822 051 30103	10k 5% 0.062W
3117	4822 051 30472	4k7 5% 0.062W
3200	4822 051 30221	220Ω 5% 0.062W
3201	4822 117 12925	47k 1% 0.063W 0603
3202	4822 051 30471	470Ω 5% 0.062W
3203	4822 051 30273	27k 5% 0.062W
3204	4822 117 12925	47k 1% 0.063W 0603
3205	4822 051 30221	220Ω 5% 0.062W
3206	4822 117 12925	47k 1% 0.063W 0603
3207	4822 051 30273	27k 5% 0.062W
3208	4822 117 12925	47k 1% 0.063W 0603

3209	4822 051 30471	470Ω 5% 0.062W
3210	4822 051 30471	470Ω 5% 0.062W
3211	4822 051 30101	100Ω 5% 0.062W
3212	4822 051 30689	68Ω 5% 0.063W 0603 RC21 RST SM
3213	4822 051 30471	470Ω 5% 0.062W
3214	4822 051 30471	470Ω 5% 0.062W
3215	4822 051 30101	100Ω 5% 0.062W
3216	4822 051 30689	68Ω 5% 0.063W 0603 RC21 RST SM
3217	4822 051 30151	150Ω 5% 0.062W
3218	4822 051 30101	100Ω 5% 0.062W
3219	4822 051 30472	4k7 5% 0.062W
3220	4822 051 30472	4k7 5% 0.062W
3221	4822 051 30472	4k7 5% 0.062W
3222	4822 117 13632	100k 1% 0603 0.62W
3223	4822 051 30471	470Ω 5% 0.062W
3224	4822 051 30151	150Ω 5% 0.062W
3225	4822 051 30471	470Ω 5% 0.062W
3226	4822 051 30472	4k7 5% 0.062W
3227	4822 051 30471	470Ω 5% 0.062W
3228	4822 051 30222	2k2 5% 0.062W
3229	4822 051 30689	68Ω 5% 0.063W 0603 RC21 RST SM
3230	4822 051 30759	75Ω 5% 0.062W
3231	4822 051 30561	560Ω 5% 0.062W
3232	4822 051 30101	100Ω 5% 0.062W
3233	4822 051 30471	470Ω 5% 0.062W
3234	4822 051 30339	33Ω 5% 0.062W
3235	4822 051 30689	68Ω 5% 0.063W 0603 RC21 RST SM
3236	4822 051 30472	4k7 5% 0.062W
3237	4822 051 30562	5k6 5% 0.063W 0603 RC21 RST SM
3238	4822 051 30479	47Ω 5% 0.062W
3239	4822 051 30472	4k7 5% 0.062W
3240	4822 051 30102	1k 5% 0.062W
3241	4822 117 12925	47k 1% 0.063W 0603
3242	4822 051 30471	470Ω 5% 0.062W
3243	4822 117 12925	47k 1% 0.063W 0603
3244	4822 051 30272	2k7 5% 0.062W
3245	4822 051 30102	1k 5% 0.062W
3246	4822 117 12925	47k 1% 0.063W 0603
3247	4822 051 30471	470Ω 5% 0.062W
3248	4822 117 12925	47k 1% 0.063W 0603
3249	4822 051 30102	1k 5% 0.062W
3250	4822 117 12925	47k 1% 0.063W 0603
3251	4822 051 30471	470Ω 5% 0.062W
3252	4822 051 30471	470Ω 5% 0.062W
3253	4822 051 30472	4k7 5% 0.062W
3254	4822 051 30759	75Ω 5% 0.062W
3255	4822 051 30472	4k7 5% 0.062W
3257	4822 051 30759	75Ω 5% 0.062W
3258	4822 051 30471	470Ω 5% 0.062W
3259	4822 051 30339	33Ω 5% 0.062W
3260	4822 051 30561	560Ω 5% 0.062W
3261	4822 051 30472	4k7 5% 0.062W
3262	4822 051 30759	75Ω 5% 0.062W
3263	4822 051 30472	4k7 5% 0.062W
3264	4822 051 30479	47Ω 5% 0.062W
3266	4822 051 30759	75Ω 5% 0.062W
3267	4822 051 30472	4k7 5% 0.062W
3268	4822 051 30101	100Ω 5% 0.062W
3269	4822 051 30689	68Ω 5% 0.063W 0603 RC21 RST SM
3270	4822 051 30471	470Ω 5% 0.062W
3271	4822 051 30759	75Ω 5% 0.062W
3272	4822 051 30273	27k 5% 0.062W
3273	4822 117 12925	47k 1% 0.063W 0603
3275	4822 051 30272	2k7 5% 0.062W
3276	4822 051 30472	4k7 5% 0.062W
3277	4822 051 30561	560Ω 5% 0.062W
3278	4822 051 30561	560Ω 5% 0.062W

-D-

6208 9340 548 63115 PDZ15B



7102	4822 130 60511	BC847B
7103	4822 130 60511	BC847B
7104	4822 130 60511	BC847B
7105	4822 130 60511	BC847B
7106	4822 130 40854	BC327
7200	4822 130 42804	BC817-25
7201	4822 130 42804	BC817-25
7202	4822 130 60511	BC847B
7203	4822 130 60511	BC847B
7204	4822 130 60511	BC847B
7205	4822 130 60373	BC856B
7206	4822 130 60511	BC847B

7207	4822 130 60511	BC847B
7208	4822 130 60511	BC847B
7209	4822 130 60511	BC847B
7210	4822 130 42804	BC817-25
7211	4822 130 42804	BC817-25
7212	4822 130 60511	BC847B
7213	4822 130 60373	BC856B
7214	4822 130 60511	BC847B
7215	4822 130 42804	BC817-25
7216	4822 130 42804	BC817-25
7217	4822 130 60511	BC847B
7218	4822 130 60511	BC847B
7219	4822 130 42804	BC817-25
7220	4822 130 42804	BC817-25
7500	9322 134 86668	LF80C
7501	9322 135 59671	STV6411AD

# 11. Errata

## 11.1 Revision List

### 11.1.1 Manual 3122 785 12331

***From production start, the new print layout of the Pscan board has been introduced.***

- In this service manual the circuit diagrams, print layout and the belonging parts list are added.

***In the manual 3122 785 12330, the Double Scart circuit diagrams and print layout was left out.***

- In this version of the service manual, the circuit diagrams and print layout are added.

***In this version, the Layout of Menu script, Audio nuclei table 5.8.1, Video nuclei table 5.8.7 and Furore nuclei table 5.8.8 are updated.***

***In this version, the value of C2102, C2129 and C2131 in the parts list of Front board has been changed to 470nF 50V.***